

Prepared for
Midas Gold Idaho, Inc., Valley County, Idaho



DRAFT

Fishway Operations and Management Plan

June 2019

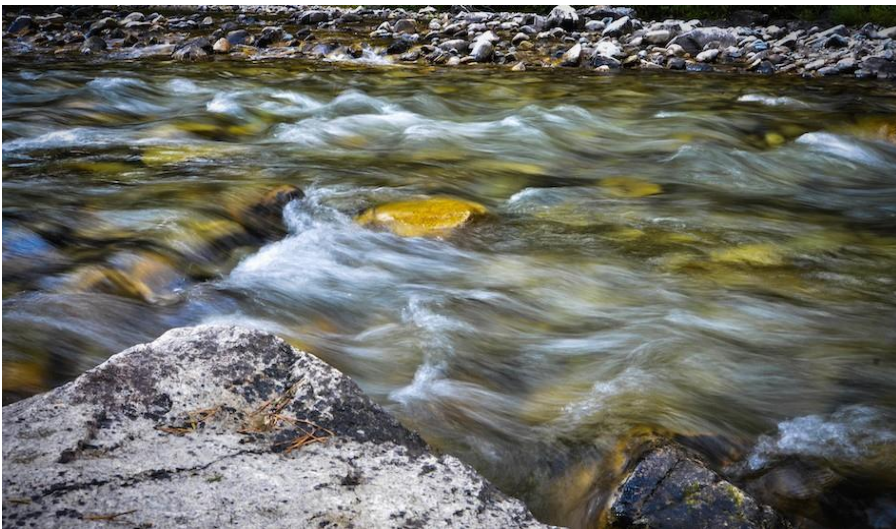
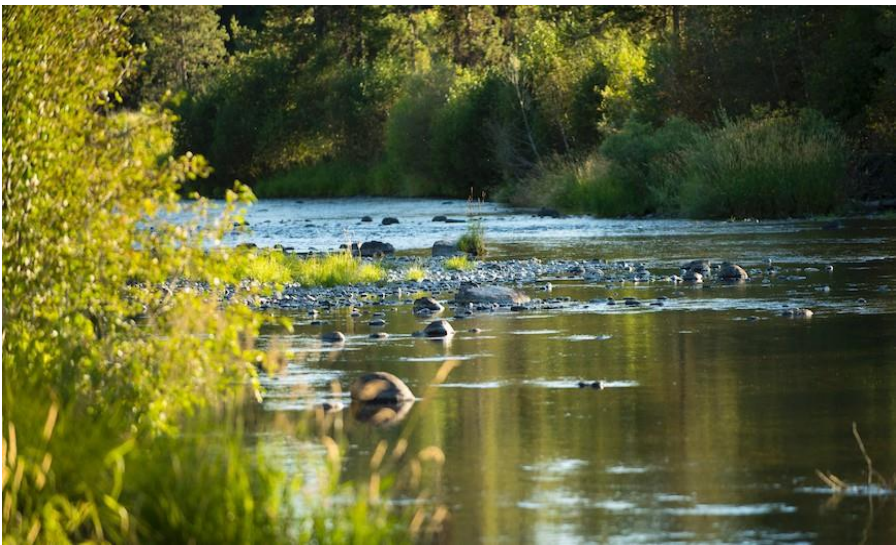

DRAFT

Fishway Operations and Management Plan

Prepared for
Midas Gold Idaho, Inc.
Valley County, Idaho
June 28, 2019

This is a draft and is not intended to be a final representation of the work done or recommendations made by Brown and Caldwell. It should not be relied upon; consult the final report.



950 West Bannock Street, Suite 350
Boise, ID 83702

Table of Contents

List of Figures.....	v
List of Tables	vi
List of Abbreviations	vii
1. Introduction	1-1
1.1 EFSFSR Tunnel and Fishway Background.....	1-2
1.1.1 Purpose and Context.....	1-2
1.1.2 Timeline.....	1-2
1.1.3 EFSFSR Discharge.....	1-3
1.1.4 Goals and Objectives.....	1-5
1.2 ESA Section 7 Consultation.....	1-6
1.3 Target Fish Species	1-7
1.3.1 Chinook Salmon	1-8
1.3.2 Bull Trout.....	1-8
1.3.3 Steelhead.....	1-9
2. Fishway Design/Function Overview	2-1
2.1 Operational/Design Criteria	2-1
2.2 EFSFSR Tunnel Elements and Function.....	2-3
2.2.1 South Portal Area	2-4
2.2.2 Tunnel Fishway and Accessway.....	2-8
2.2.3 Tunnel Lighting.....	2-9
2.2.4 North Portal Area	2-10
3. Operations and Maintenance.....	3-1
3.1 Initial Startup and Testing.....	3-1
3.2 Surface Conveyance Inspection and Maintenance	3-1
3.2.1 Primary Sediment Trap and Sediment Dropout Reach.....	3-1
3.2.2 South Channel Debris Rack.....	3-2
3.2.3 Fishway Entry Features	3-3
3.3 Tunnel Portals.....	3-3
3.4 Tunnel.....	3-3
3.5 Fishway Channel.....	3-3
3.6 North Channel Fishway Features.....	3-4
3.7 North Channel to EFSFSR Confluence	3-4
3.8 Fish Monitoring Instrumentation	3-4
3.9 Tunnel Lighting.....	3-4
3.10 Fishway Inspection	3-5

3.11	Trap and Haul.....	3-5
3.12	Entrainment and Fish Salvage.....	3-6
3.13	Tunnel/Fishway Decommissioning.....	3-7
4.	Monitoring, Evaluation, and Adaptive Management.....	4-1
4.1	Adaptive Management Approach	4-1
4.2	Fishway Monitoring and Evaluation.....	4-2
4.2.1	Camera/Video Monitoring	4-2
4.2.2	Passive Integrated Transponder Tag Array.....	4-3
4.3	Biological Monitoring and Evaluation	4-4
4.4	Adaptive Management Reporting and Implementation	4-6
5.	Limitations	5-1
6.	References	6-1
	Appendix A: EFSFSR Streamflows.....	A-1
	Appendix B: Sediment Transport	B-1

List of Figures

Figure 1-1. Timeline for the EFSFSR tunnel from construction to tunnel decommissioning	1-3
Figure 1-2. Average daily flows in the EFSFSR by date at the North Portal of the proposed tunnel for period 1929-2017 (from Rio ASE 2019)	1-5
Figure 2-1. An isometric illustration of the south portal section of the EFSFSR tunnel	2-4
Figure 2-2. Primary sediment trap and sediment drop out zone located upstream of the debris screen	2-5
Figure 2-3. The debris screen structure is located just upstream from the flow control weir and functions to collect large wood and debris from the stream before the streamflow enters the fishway	2-6
Figure 2-4. Debris screen displaying debris rack panels and upper and lower bar spacing	2-6
Figure 2-5. Overhead view of the flow control weir located between the debris rack and fishway.....	2-7
Figure 2-6. Picket panel section atop the flow control weir that would become active at streamflows greater than 25 cfs (Jensen 2019)	2-8
Figure 2-7. Cross-section view of the EFSFSR tunnel displaying the access way, fishway divider wall, and fishway	2-8
Figure 2-8. Cross-section view of the elevated fishway weir	2-9
Figure 2-9. Isometric illustration of the north portal section of the EFSFSR tunnel.....	2-10
Figure 2-10. North portal area displaying boulder weir control structures that extend from the fishway entrance to natural stream channel	2-11
Figure 3-1. Average daily flows in the EFSFSR at the North Portal of the proposed tunnel for the period 1929-2017 (from Rio ASE 2019). A dashed line represents the 25 cfs flow necessary to crest the flow control weir.....	3-6
Figure 4-1. Adaptive management cycle for the EFSFSR fishway	4-1
Figure 4-2. Screen image from a motion-activated fishway monitoring system.....	4-3

List of Tables

Table 1-1. Species and life stage with time periods used to estimate 5% and 95% exceedance streamflows	1-4
Table 1-2. Size and swimming capabilities of Chinook salmon, bull trout, and steelhead	1-7
Table 1-3. General fish use and periodicity for different life stages of spring/summer Chinook (Miller 2018)	1-8
Table 1-4. General fish use and periodicity for different life stages of bull trout (Miller 2018)	1-8
Table 1-5. General fish use and periodicity for different life stages of steelhead (Miller 2018).....	1-9
Table 2-1. Fish Passage Facility Design Criteria (NMFS 2011)	2-1
Table 4-1. Fishway performance measures and standards for the fishway entrance, fishway ladder, and south portal debris management.	4-4
Table 4-2. Performance measures and standards for fish passage at the EFSFSR tunnel and fishway.	4-5

List of Abbreviations

CFD	Computational Fluid Dynamic
cf	cubic feet
cfs	cubic feet per second
cy	cubic yard
EDF	Energy Dissipation Factor
EFH	Essential Fish Habitat
EFSFSR	East Fork of the South Fork of the Salmon River
ESA	Endangered Species Act
FHWA	Federal Highway Administration
FOMP	Fishway Operations and Management Plan
FOS	Factor of Safety
fps	feet per second
lbs	pounds
MGII	Midas Gold Idaho, Inc.
NOAA	National Oceanic and Atmospheric Administration
PIT	Passive Integrated Transponder
PRO	Plan of Restoration and Operations
SFSR	South Fork Salmon River
SGP	Stibnite Gold Project
USACE	United States Army Corps of Engineers
USFWS	U.S. Fish and Wildlife Service
WDFW	Washington Department of Fish and Wildlife
YPP	Yellow Pine pit
ZOP	Zone of Passage

Section 1

Introduction

The purpose of this document is to describe Midas Gold Idaho, Inc.'s (Midas Gold or MGII) proposed Fishway Operations and Management Plan (FOMP) for the fishway designed for the East Fork of the South Fork of the Salmon River (EFSFSR) Tunnel (McMillen Jacobs 2018)¹. The need for this plan emerged through discussions with the National Oceanic and Atmospheric Administration (NOAA) Fisheries and the U.S. Fish and Wildlife Service (USFWS) (jointly 'the Services') and other participants during the Endangered Species Act (ESA) informal consultation meetings during 2019, following the Services' review of the EFSFSR Tunnel Design Documentation Report (McMillen Jacobs 2018b). The Services requested additional information about the proposed operation and management of the proposed fishway, including information about how the fishway could be managed adaptively in response to observed fish use and fish passage performance. Together, this FOMP and the fishway design (McMillen Jacobs 2018) constitute a complete 30 percent design package for review by the U.S. Forest Service (USFS), the Services, and other participants in the ESA informal consultation. These reports are also designed to support the development of the biological assessment for the ESA Section 7 consultation process for the Stibnite Gold Project (SGP).

The successful operation of the proposed tunnel fishway during mine operations² involves some uncertainty. For example, the number and species of fish that will arrive at the tunnel fishway is not fully understood, and the successful entry and passage of fish will need to be monitored to understand fish use of the tunnel. There are also management options to consider, including the backup use of trap and haul if the fishway is not operating satisfactorily, and the relationship to Chinook salmon stocking that occurs periodically in the EFSFSR upstream of the fish passage barrier at the cascade upstream of the Yellow Pine pit (YPP) lake. Because of these and other uncertainties, a suitable option for operation and management of the tunnel fishway is an adaptive management approach. "Adaptive management is a system of management practices based on clearly identified outcomes and monitoring to determine whether management actions are meeting desired outcomes; and, if not, facilitating management changes that will best ensure that outcomes are met or re-evaluated. Adaptive management recognizes that knowledge about natural resource systems is sometimes uncertain." (43 CFR 46.30).

The FOMP is organized into four sections, as follows:

- Section 1 Introduction, which include Tunnel and Fishway Background and describes the purpose of the tunnel and fishway, general timeline for construction, the flows expected to occur through the tunnel, the target species, and the goals and objectives for the fishway operation.
- Section 2 Fishway Design/Function Overview describes the operational and design criteria and overall function of the tunnel fishway and how it would be operated. This information

¹ The Yellow Pine pit (YPP; a.k.a. the Glory Hole) was first mined during the 1930s and 1940s and then abandoned in the late 1950s and never reactivated. The flow of the EFSFSR currently cascades down an unreclaimed highwall into the abandoned pit and the existing YPP lake. The high-gradient cascade still exists and continues to be a barrier to upstream fish passage (BC 2019a).

² Upon completion of mining operations, the open pit would be backfilled, and a longstanding migration barrier would be removed as the EFSFSR stream channel is reestablished across the top of the YPP providing for long-term volitional fish passage (Rio ASE 2019).

supplements what was provided in the EFSFSR Tunnel Design Documentation Report (McMillen Jacobs 2018).

- Section 3 Operations and Management describes the anticipated operation and maintenance requirements for the project and serves as the basis for developing detailed operation and maintenance manuals in future design phases.
- Section 4 Monitoring, Evaluation, and Adaptive Management describes the how the hydraulic conditions, fish use, and performance of the tunnel fishway will be measured and evaluated, and the design of the adaptive management component of the plan.

Since before the inception of the SGP Project Plan of Restoration and Operations (PRO), MGII has been committed to restoring passage for ESA-listed species to the upper EFSFSR that was disconnected and isolated from use by these species since the late 1930s. Restoring passage to such areas is recognized to be one of the most effective forms of restoration for migratory and anadromous salmonids (Roni et al. 2014). The presence of valuable spawning and rearing habitat upstream of the YPP cascade barrier, the successful spawning and rearing of Chinook salmon planted upstream of the barrier (MWH 2017, BC 2019b), and documented outmigration of juvenile Chinook salmon from production in the upper EFSFSR from that stocking (BC 2019b) all point to the value of providing passage during mining and restoring permanent volitional passage as proposed by MGII.

1.1 EFSFSR Tunnel and Fishway Background

1.1.1 Purpose and Context

The primary purpose of the EFSFSR tunnel (or tunnel) is to convey streamflow around the YPP during mine operations. There are no secondary water storage or electrical generation capabilities associated with the tunnel. The EFSFSR tunnel and fishway would operate without additional water storage capabilities, controlled water releases, or pumped attraction water (i.e., auxiliary water supply) systems typically associated with some fishways. However, one of the primary benefits in relation to the fishway is that 100 percent of streamflow is available for attraction water at the outlet of the tunnel.

The tunnel represents an important part of the overall SGP environmental mitigation measures by enabling re-establishment of a volitional migratory pathway for anadromous fish to spawning grounds upstream of the pit. Target fish species that will benefit from fish passage would include Chinook salmon (*Oncorhynchus tshawytscha*), steelhead (*O. mykiss*), and bull trout (*Salvelinus confluentus*). The EFSFSR tunnel feasibility design includes tunnel routing, hydraulic analysis, and civil and structural design for the tunnel, in-tunnel fishway, and appurtenant structures at the portals. Several supporting studies have been completed including fish passage design criteria evaluation, tunnel size alternatives evaluation, geotechnical analysis, rock mass characterization, portal alternatives evaluation, and fishway alternatives analysis.

1.1.2 Timeline

The timeline for the EFSFSR tunnel is approximately 15 years from activation of the tunnel to decommissioning (Figure 1-1). Construction of the tunnel would require an additional two years prior to activation. The temporary fishway would allow fish passage during the 12-year period of mine operations. By year 13, a portion of the EFSFSR streamflow would be diverted into the reestablished stream channel. The following year, all streamflow would be diverted to the EFSFSR so that all juvenile and adult fish passage would occur through the newly established stream channel. In the two-year period after the tunnel is deactivated but before it is decommissioned permanently, the

tunnel could be used to divert some portion of high streamflows to avoid potential damage to the newly restored stream channel and riparian zone (Rio ASE 2019)³.

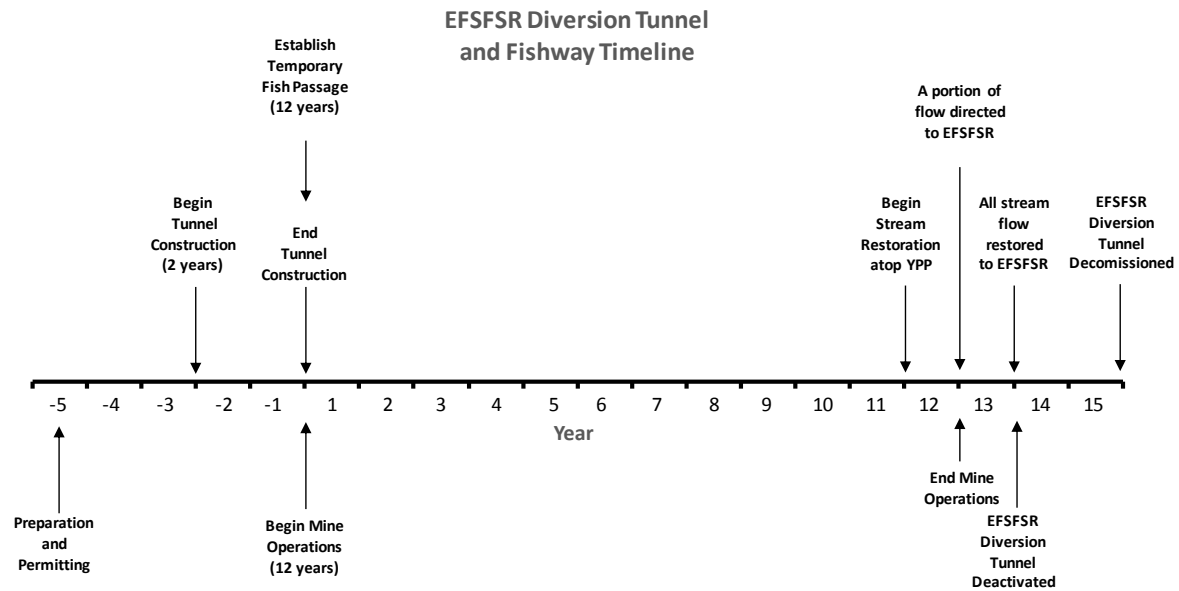

Figure 1-1. Timeline for the EFSFSR tunnel from construction to tunnel decommissioning

1.1.3 EFSFSR Discharge

Barrett and Miller (2018) described hydrology data used to approximate streamflows at the proposed EFSFSR tunnel and 5th and 95th percentile exceedance flows (see Appendix A). The 5th and 95th percentile exceedance streams flows were selected based on fishway design recommendations provided for high (5th exceedance) and low (95th exceedance) streamflows (NMFS 2011). Those exceedance flows are defined as:

5 Percent Exceedance Streamflow. The design high flow is the mean daily average streamflow that is exceeded 5 percent of the time during periods when migrating fish are normally present at the site.

95 Percent Exceedance Streamflow. The design low flow is the mean daily average streamflow that is exceeded 95 percent of the time during periods when migrating fish are normally present at the site.

The EFSFSR gage near Stibnite is close to the proposed location of the downstream portal (“North Portal”) but streamflow data was limited to 2011 to 2017. A longer period of streamflow data was available for Johnson Creek near Yellow Pine, Idaho (1929-2017). The Johnson Creek gage was used to statistically extend the record at the EFSFSR gage (Rio ASE 2019). The streamflow data were used to calculate the 5th and 95th percentile exceedance flows over the preceding 25 years (1993-2017) (Table 1-1) (McMillen Jacobs 2018).

³ During this 2-year period, the portion of streamflows greater than bankfull flows ($Q_{bf}=215$ cfs; EFSFSR Reach 3) could be diverted to protect the newly established stream channel and riparian zone (Rio ASE 2019; Appendix D).

Table 1-1. Species and life stage with time periods used to estimate 5% and 95% exceedance streamflows

Species and life stage	Time Period	Percent Exceedance Flows	
		5%	95%
Chinook Salmon (adult)	July 8 - September 30	54	8.1
Bull Trout (adult)	July 8 - September 30	54	8.1
Steelhead (adult)	April 1 - May 31	239	9.0
Juvenile Salmonids	Year-round	139	8.2

Migration periods for target fish passage species have been refined with the development and inclusion of new information (Table 1-1). Additional information from spawning grounds surveys on Sugar Creek for bull trout and Chinook salmon along with adult pit tag detections on the EFSFSR at Parks Creek were included in the development of migration periods. That additional information was included in the development of general periodicity information on target fish species (Miller 2018). However, that periodicity and potential fish use was developed from a much larger geographical scale relevant to the entire EFSFSR watershed and not specific to the proposed fishway entrance. Additional spawning ground information helped to refine the end of the migration period and also demonstrated that adult Chinook spawned earlier than bull trout in the upper EFSFSR. Barrett and Miller (2018) refined the migration period with an arrival estimate at the proposed fishway entrance from July 8 to end of September to be inclusive of the adult migration period for adult Chinook salmon and bull trout⁴. No refinement for the steelhead migration period was warranted⁵.

The general seasonal flow pattern in the EFSFSR includes a period of high flows associated with snowmelt from May to early July, moderate but increasing (April) or decreasing (July) flows on either side of the annual snowmelt peak, and relatively constant low flows during the remainder of the year (Figure 1-2).

⁴ On July 11, 2018 one adult Chinook was observed just downstream from YYP lake which supports the early July arrival of adult Chinook (M. Miller, personal communication, July 11, 2018).

⁵ Over a nine-year period (2009-2017) of adult PIT tagged steelhead detections in the EFSFSR only two adult steelhead were detected before April 1. Those two adult steelhead were detected on March 30, 2015 and March 31, 2015. The PIT tag array (Station ESS) is located at river mile 12.5 on the EFSFSR, approximately 12.7 miles downstream of Midas Gold's proposed tunnel (i.e., at river mile 25.2).

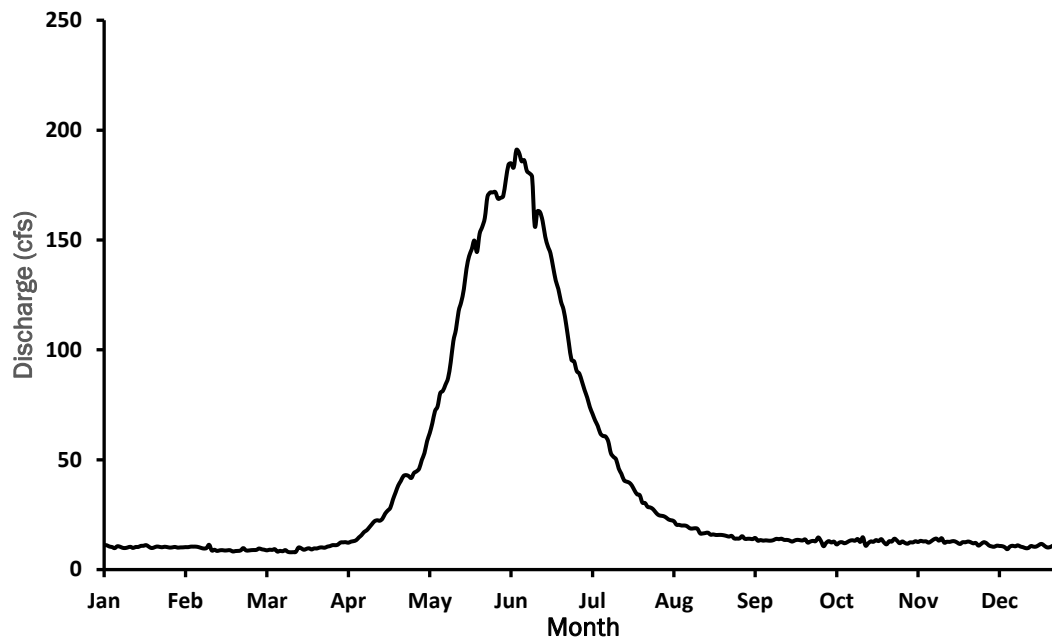

Figure 1-2. Average daily flows in the EFSFSR by date at the North Portal of the proposed tunnel for period 1929-2017 (from Rio ASE 2019)

1.1.4 Goals and Objectives

Providing fish passage should produce tangible biological benefits. The primary benefit of including an adult fishway during operations is to proactively produce a 14-year head start on reestablishing natural production prior to restoring the EFSFSR stream channel across the YPP. Indeed, efforts to increase spring/summer Chinook salmon production in the upper EFSFSR have been actively pursued with the transport and release of mature adult Chinook salmon upstream from the YPP. Returning adults from those efforts are anticipated but there is currently no passage available past the YPP fish passage barrier.

Additional benefits of fish passage would also accrue for bull trout and steelhead that are not supplemented with hatchery-origin fish in the upper EFSFSR. Large migratory bull trout are known to occur in the YPP lake and EFSFSR below the lake which may indicate that the migration pathway is still viable (Hogen 2002; Hogen and Scarnecchia 2006; BC 2018b). Steelhead are known to spawn in the EFSFSR and Johnson Creek (Thurow 1987) and a few *O. mykiss* have recently been captured in the YPP (BC 2018b). Reviews of the effectiveness of different habitat improvement techniques have consistently ranked barrier removal as the most effective methods for increasing fish numbers and a highest priority habitat improvement measure for salmon, steelhead, and other stream fishes (Roni et al. 2002, 2008, 2014). As noted in Hillman et al. (2016), the rate at which salmon and trout recolonize formerly inaccessible habitats is highly dependent on the amount and quality of habitat upstream of the barrier and the size of the downstream source population(s).

Tangible benefits of reestablishing early fish passage include: providing a migration pathway so that the progeny of out-planted adult Chinook salmon can return to spawn in the upper EFSFSR; providing a 14-year temporal benefit for migratory bull trout to reestablish a migratory life form in the upper EFSFSR; providing a 14-year temporal benefit for natural-origin anadromous steelhead to recolonize

the upper EFSFSR; and, the potential benefits of increased abundance, productivity, and spatial structure of local populations from increased access to spawning and rearing habitat.

The main goals of the EFSFSR tunnel and fishway are to convey streamflows around the YPP and provide temporary fish passage during mine operations and stream restoration. The primary objectives include:

1. Convey streamflows around the YPP during mine operations and during stream restoration until final decommissioning of the EFSFSR tunnel.
2. Provide safe, timely and effective adult fish passage via the fishway (preferred) and all associated structures or provide adult passage by trap and haul if needed.
3. Provide safe, timely, and effective year-around juvenile fish passage downstream through the fishway and through the accessway at higher streamflows.
4. For a period of approximately 2 years, divert a portion of streamflow to the EFSFSR tunnel during high flows to avoid damage to the newly restored EFSFSR stream channel and newly planted riparian vegetation.

Elements of the fishway will be designed and implemented to provide safe, timely, and effective fish passage (USFWS 2017). Safe, timely, and effective fish passage characteristic are defined as:

- **Safe Passage:** The movement of fish through the zone of passage (ZOP) that does not result in unacceptable stress, incremental injury, or death of the fish. If movement past a barrier results in delayed mortality or a physical condition that impairs subsequent migratory behavior, growth, or reproduction, it should not be considered safe passage.
- **Timely Passage:** The movement of fish through the ZOP that proceeds without materially significant delay or impact to essential behavior patterns or life history requirements.
- **Effective Passage:** The successful movement of target species through the ZOP resulting from a favorable alignment of structural design, project operations, and environmental conditions during one or more key periods. Effectiveness includes both qualitative and quantitative components; efficiency, and the hyponyms *passage efficiency* and *attraction efficiency*, are typically reserved for quantitative evaluations.

1.2 ESA Section 7 Consultation

The SGP and this FOMP will undergo review and require consultation under the ESA as it may affect federally listed threatened and endangered species. The EFSFSR tunnel is just one component of the SGP that may influence ESA-listed fish species. The EFSFSR tunnel would provide temporary fish passage for species such as spring/summer Chinook salmon, steelhead, and bull trout. Westslope cutthroat trout (*O. clarkii lewisi*) may also benefit from the EFSFSR tunnel but were not included in the design analysis.

The USFS is the lead federal agency for the ESA consultation, and the management agencies are USFWS and National Marine Fisheries Service (NMFS). The USFWS has ESA responsibility for bull trout and NMFS has ESA responsibility for Chinook salmon and steelhead. Critical habitat has been designated for Chinook salmon, steelhead, and bull trout and occurs within the project area. For Chinook salmon, critical habitat includes all streams in the EFSFSR drainage that are currently occupied by Chinook salmon, or within habitat historically accessible by Chinook salmon. Steelhead critical habitat includes the EFSFSR upstream to, and including, Sugar Creek. Critical habitat for bull trout includes the EFSFSR and Meadow Creek. The specific areas considered to be important as critical habitat within the project area are under consideration by the USFS and the Services in coordination with Midas Gold.

In addition to compliance with ESA, the USFS is required to comply with the Magnuson-Stevens Fishery Conservation and Management Act on actions that might adversely affect essential fish habitat (EFH), including habitats that fish rely on throughout their life cycles, and the Act requires consultation with NOAA Fisheries. EFH encompasses habitats necessary to allow enough production of aquatic species with commercial value to support a long-term sustainable fishery and contribute to a healthy ecosystem, including spawning and rearing habitats. EFH is coincident with designated critical habitat for Chinook salmon in Project area watersheds. EFH consultations are typically combined with existing environmental review procedures, such as those required under the National Environmental Policy Act (EIS) and the ESA.

The lead federal agency designated Midas Gold as the non-federal representative for consultation under the ESA and as having “Applicant” status under ESA for the SGP. As such, Midas Gold will be engaged in informal and formal consultation with USFS and the Services in the process of considering the potential impacts of the SGP including the impacts of the EFSFSR tunnel on federally listed species and their designated critical habitat. Midas Gold identified fish passage within the EFSFSR tunnel as a mitigation opportunity.

1.3 Target Fish Species

Target fish species that will benefit from the EFSFSR tunnel include Chinook salmon, bull trout, and steelhead. There is potential for some resident species such as westslope cutthroat trout to utilize the fishway; however, the fishway has not been evaluated or designed for other species.

The target fish species for which the EFSFSR tunnel fishway was designed to pass most efficiently were adult spring/summer Chinook salmon and bull trout (Barrett and Miller 2018). However, recent hydraulic modeling for steelhead also suggests favorable passage conditions during higher streamflow as well (Jensen 2019).⁶ Swimming capabilities of target fish species are presented in Table 1-2.

Table 1-2. Size and swimming capabilities of Chinook salmon, bull trout, and steelhead

Species	Average Size (lbs.)	Swimming Capabilities (fps)		Source
		Sustained ¹	Burst ²	
Chinook Salmon	12	<11	<22	USACE 1991
Bull Trout	8	<2.5	<6.6	Preliminary data
Steelhead	8	<15	<26	USACE 1991

Notes:

¹ Sustained speed is the speed at which fish swim through difficult areas and represents the mid-range of energy expenditure per unit distance traveled; and

² Burst speed (also known as darting speed) is the speed attained for purposes of escape or feeding and represents the high range of energy expenditure per unit distance traveled (Bell 1990).

fps = feet per second

lbs. = pounds

USACE = United States Army Corps of Engineers

⁶ Target species include ESA-listed spring/summer Chinook salmon, bull trout, and steelhead. Westslope cutthroat trout (*O. clarkii lewisii*) are also expected to use the fishway but are not considered a target species for design considerations.

1.3.1 Chinook Salmon

The adult combined migration and spawning period for spring/summer Chinook extends from May to mid-September (Miller 2018; NPT 2018; Rabe et al. 2017) (Table 3). Redd surveys conducted in Sugar Creek (2008-2016) document that spawning begins in August and ends mid-September (NPT 2018). The earliest known spawning occurred on August 13, 2010 and the latest occurred on September 10, 2009. Barrett and Miller (2018) refined the general periodicity displayed in Table 1-1 to approximate when Chinook salmon would begin to pass the proposed EFSFSR tunnel. Adult Chinook salmon are expected to arrive at the location of the proposed tunnel entrance in early July.

Table 1-3. General fish use and periodicity for different life stages of spring/summer Chinook (Miller 2018)

Species	Life Stage	Jan	Feb	Mar	Apr	May	Jun	Jul	Aug	Sep	Oct	Nov	Dec
Spring/Summer Chinook	Adult Migration												
	Adult Spawning												
	Juvenile Emigration												

Based on data from Johnson Creek, the juvenile out-migration period is expected to occur from March into November (Rabe et al. 2006). Smolts typically emigrated during the early spring months of March through May, while parr emigrated throughout the summer, and pre-smolts emigrated in the fall (Rabe et al. 2006).

1.3.2 Bull Trout

Bull trout life history strategies and migratory patterns have been studied in the Secesh River and EFSFSR watersheds (Hogen and Scarnecchia 2006; Watry and Scarnecchia 2008). In the Secesh River watershed, Watry and Scarnecchia (2008) found that upstream migrations occurred during late June and early July with migrations into two spawning tributaries during late July and early August. In the EFSFSR, bull trout migrated upstream in June and July and moved further upriver into smaller tributaries to spawn in August and September (Hogen and Scarnecchia 2006) (Table 1-4).

Table 1-4. General fish use and periodicity for different life stages of bull trout (Miller 2018)

Species	Life Stage	Jan	Feb	Mar	Apr	May	Jun	Jul	Aug	Sep	Oct	Nov	Dec
Bull Trout	Adult Migration												
	Adult Spawning												
	Juvenile Emigration												

Adult spawning periods reported for the South Fork Salmon River (SFSR) subbasin occur from late August to mid-October (Burns et al. 2005). However, biotelemetry studies on bull trout in both the Secesh and EFSFSR watersheds indicate spawning likely occurs from late August through mid-September (Hogen and Scarnecchia 2006; Watry and Scarnecchia 2008). In both studies, bull trout typically left spawning tributaries by end of September. In the EFSFSR, spawning areas included Tamarack, Profile, and Sugar creeks and some tributaries to those streams (Burns et al. 2005). As reported by Hogen (2002; cited in Burns et al. 2005), spawning occurred over a short, definite time, from September 1 through 15 with all spawning completed by September 20. Bull trout redd surveys conducted in Sugar Creek (2009-2014, 2016) show that spawning begins in late August and ends

near mid-September (Nez Perce Tribe data, January 2018). The earliest redds in Sugar Creek was reported on August 28 and the last redds reported on September 16.

Juvenile bull trout emigration is not well-documented in the SFSR subbasin. However, emigrant behavior might be approximated from other sources. Downs et al. (2006) observed that juvenile bull trout emigrated in pulses with one occurring in the spring and another in fall. Following the large pulse of age one and older juveniles emigrating in spring, they observed a second peak of downstream movement in fall (Downs et al. 2006). Lower emigration rates were noted in late July and August. Bellerud et al. (1997) also identified two emigration peaks of juvenile bull trout separated by a period of low movement in July in Oregon's Grand Ronde River system. Juvenile emigration in the SGPaquatic resource area will probably follow similar patterns as those noted elsewhere. Therefore, juvenile emigration is likely to occur from April to end of November with little emigration occurring during winter months.

1.3.3 Steelhead

Information suggests that steelhead ascend the Columbia River in late summer and overwinter in the Snake and Salmon rivers before entering the SFSR in spring (Mallet 1970; Thurow 1987). Thurow (1987) noted that wild steelhead are near the SFSR around mid-September with steelhead staging at the mouth of the SFSR in the fall and spring. Passive Integrated Transponder (PIT) tag data from the EFSFSR near Parks Creek showed an adult migration period from late March to end of May (Table 1-5). However, only two PIT tagged steelhead (less than 1 percent) were documented in late March so April 1 to end of May was used to estimate exceedance streamflows (see Table 1-1).

Table 1-5. General fish use and periodicity for different life stages of steelhead (Miller 2018)

Species	Life Stage	Jan	Feb	Mar	Apr	May	Jun	Jul	Aug	Sep	Oct	Nov	Dec
Steelhead	Adult Migration												
	Adult Spawning												
	Juvenile Emigration												

Holubetz (1995) speculated that spawn time may be related to elevation. In high elevation tributaries, steelhead typically spawned in a narrow time frame from April 15 to May 15 (Thurow 1983; Orcutt et al. 1968). In the mainstem SFSR, Thurow (1987) observed steelhead spawning from mid-April to end of May. Tributary spawning areas included sections of Burntlog, Johnson, and Lick creeks, and East Fork of the South Fork Salmon and Secesh rivers. Steelhead began spawning in tributaries about one week later than steelhead in mainstem areas. In the aquatic resource area, spawning is likely to occur from late April to end of May.

Juvenile emigration for steelhead can occur throughout the year (USBWP 2005). Smolt trapping on the lower SFSR from March through November indicates that juvenile steelhead emigrate throughout the season with definite peaks in July and August (Albee and Orme 2011). Juvenile emigration within the Project's aquatic resource area will likely occur year-round with peak emigration occurring in summer months.

Section 2

Fishway Design/Function Overview

This section discusses the operational and design criteria used to establish the current EFSFSR tunnel design and describes the location, purpose, and function of select facility components. This section concludes with a tabulation of hydraulic conditions for depth, velocity, and energy dissipation factors (EDF) for specific elements of the EFSFSR tunnel.

The EFSFSR tunnel design is split between an accessway and fishway. As streamflows increase, the accessway provides increased water conveyance capacity as the fishway maintains its fish passage capabilities. The fishway is designed primarily for adult passage but will also serve as a passage route for juvenile fish moving downstream. No adult fish will pass through the accessway because there is an exclusion barrier at the fishway entrance and pickets placed on top of the flow control weir at the fishway exit.

2.1 Operational/Design Criteria

The operational and design criteria for the fishway were developed and documented in the EFSFSR Tunnel Design Documentation Report (McMillen Jacobs 2018) (Table 2-1). The fishway design criteria presented below are taken from *Anadromous Salmonid Passage Facility Design* (NMFS 2011), except for the maximum culvert velocities at the bottom of the table, which are taken from Federal Highway Administration (FHWA; 2007) and Washington Department of Fish and Wildlife (WDFW; 2013). The fishway design at higher flows diverts flow down the accessway, maintaining lower flow rates and velocities in the fishway that should allow for steelhead passage during their migration period from April to June.

Table 2-1. Fish Passage Facility Design Criteria (NMFS 2011)

Fishway Entrance			
Attraction Flow	%	5-10% of fish passage facility design high flow	Attraction flow from the fishway entrance should be between 5% and 10% of fish passage facility design high flow for streams with mean annual streamflows exceeding 1,000 cfs. For smaller streams, when feasible, use larger percentages (up to 100%) of streamflow. NMFS (2011), Section 4.2.2.3.
Minimum Width	ft	4	NMFS 4.2.2.5. Applicable to fish ladders only.
Minimum Depth	ft	6	The shape of the entrance is dependent on attraction flow requirements and should be shaped to accommodate site conditions. NMFS 4.2.2.5. Applicable to fish ladders only.
Transport Velocity	ft/s	1.5 to 4.0	NMFS 4.2.2.12.
Streaming Flow	n/a	-	Streaming flow is flow over a weir which falls into a receiving pool with water surface elevation above the weir crest elevation. NMFS 4.2.2.8. Includes fish ladder baffles.
Fish Ladder			
Hydraulic drop between fish ladder pools	in	12 maximum	NMFS 4.5.3.1.

Flow Depth	ft	1 minimum	Fishway overflow weirs should provide at least 1 foot of flow depth over the weir crest.
Minimum Pool Length	ft	8	NMFS 4.5.3.3. Applicable to fish ladders only.
Minimum Pool Width	ft	6	NMFS 4.5.3.3. Applicable to fish ladders only.
Minimum Pool Depth	ft	5	NMFS 4.5.3.3. Applicable to fish ladders only.
Turning Pools	n/a	-	Turning pools should be at least double the length of a standard fishway pool, as measured along the centerline of the fishway flow path. NMFS 4.5.3.4. Applicable to fish ladders only.
Fish Ladder Pool Energy Dissipation Factor (EDF)	ft-lb/s	4 maximum	NMFS 4.5.3.5. Applicable to fish ladders only. However, will attempt to meet this guidance for the in-tunnel fishway.
Orifice Dimensions	in	15 height 12 width	The top and sides should be chamfered 0.75 inches on the upstream side and chamfered 1.5 inches on the downstream side of the orifice. NMFS 4.5.3.7.
Lighting	n/a	See text	Ambient lighting is preferred. Abrupt lighting changes must be avoided. NMFS 4.5.3.8.
Debris Rack			
Coarse Debris Rack Velocity	ft/s	1.5	Velocity through the gross area of the coarse debris rack. NMFS 4.8.2.1.
Coarse Debris Rack Depth	n/a	Equal to the pool depth in the fishway.	NMFS 4.8.2.2. Determined by fishway depth and hydraulics.
Coarse Debris Rack Slope	n/a	1:5 H:V max	Install debris rack at slope for ease of cleaning. NMFS 4.8.2.3.
Coarse Debris Rack Bar Spacing	in	10 minimum if Chinook are present	NMFS 4.8.2.5.
Coarse Debris Rack Orientation	n/a	45° relative to the fishway flow	NMFS 4.8.2.6.
Adult Trapping Systems			
Distribution Flume Dimensions	in	15 wide 24 tall	Horizontal and vertical radius of curvature should be at least 5 times flume width to minimize risk of fish strike injuries. NMFS 6.4.1.4.
Inflow, Maximum Average Velocity	ft/s	1 maximum	NMFS 6.4.1.6.
Holding Pond Volume	ft ³ /lbs. of fish	0.25	For long-term holding (greater than 72 hours), trap holding pool volumes should be increased by a factor of three. If water temperatures are greater than 50°F, the poundage of fish held should be reduced by 5% for each degree over 50°F. NMFS 6.5.1.2.
Holding Pond Flow	gpm per adult fish	0.67	For long-term holding (greater than 72 hours), trap holding pool flow rates should be increased by a factor of three. NMFS 6.5.1.3.
Holding Pond Freeboard	ft	5-ft minimum	NMFS 6.5.1.4. A holding pond is not included in the design because trapping will occur in the first fishway pool. Fish would be transported directly to holding tank on a transport vehicle.

Crowder Clear Bar Spacing	in	0.875 maximum	Side gaps must not exceed 1 inch. NMFS 6.5.1.6.
Hopper Water Volume	ft ³ /lbs. of fish	0.15	NMFS 6.7.2.1.
Hopper Egress Opening	ft ²	3 min	NMFS 6.7.2.5.
Culvert Maximum Velocity			
Culvert Length 10 - 100 ft	fps	4	FHWA. 2007; WDFW, 2013
Culvert Length 100 - 200 ft	fps	3	FHWA. 2007; WDFW, 2013
Culvert Length > 200 ft	fps	2	FHWA. 2007; WDFW, 2013

Notes:

°F = degrees Fahrenheit

cfs = cubic feet per second

EDF = Energy Dissipation Factor

FHWA = Federal Highway Administration

ft = feet

ft² = feet squared

fps = feet per second

ft³/lbs. = volume of water per pound of fish

ft-lb/s = unit of energy equal to the amount required to raise 1 pound a distance of 1 foot per sec

gpm = gallons per minute

in = inch

n/a = not applicable

WDFW = Washington Department of Fish and Wildlife

2.2 EFSFSR Tunnel Elements and Function

The following sections provide a brief discussion of the location, purpose, and function of different elements the EFSFSR tunnel. Specific elements of the project are discussed in order based on their location from the most upstream components to downstream (south portal to north portal). These elements include:

- South Portal Area
 - Sediment Trap/Resting Pool
 - Sediment Collection Channel/Drop Out Zone
 - Debris rack
 - Flow Control Weir and Picket Panels
- Tunnel Fishway and Accessway
- North Portal Area
 - Juvenile Orientation Pool
 - Exclusion Barrier
 - Adult Holding Pool
 - Rock Weirs
 - Transition Zone

2.2.1 South Portal Area

The south portal area is the most upstream location of the EFSFSR tunnel (Figure 2-1). For juvenile downstream migrants, the south portal area would be the first element of the EFSFSR tunnel encountered. For adult upstream migrants, the south portal area would be the last element of the EFSFSR tunnel encountered.

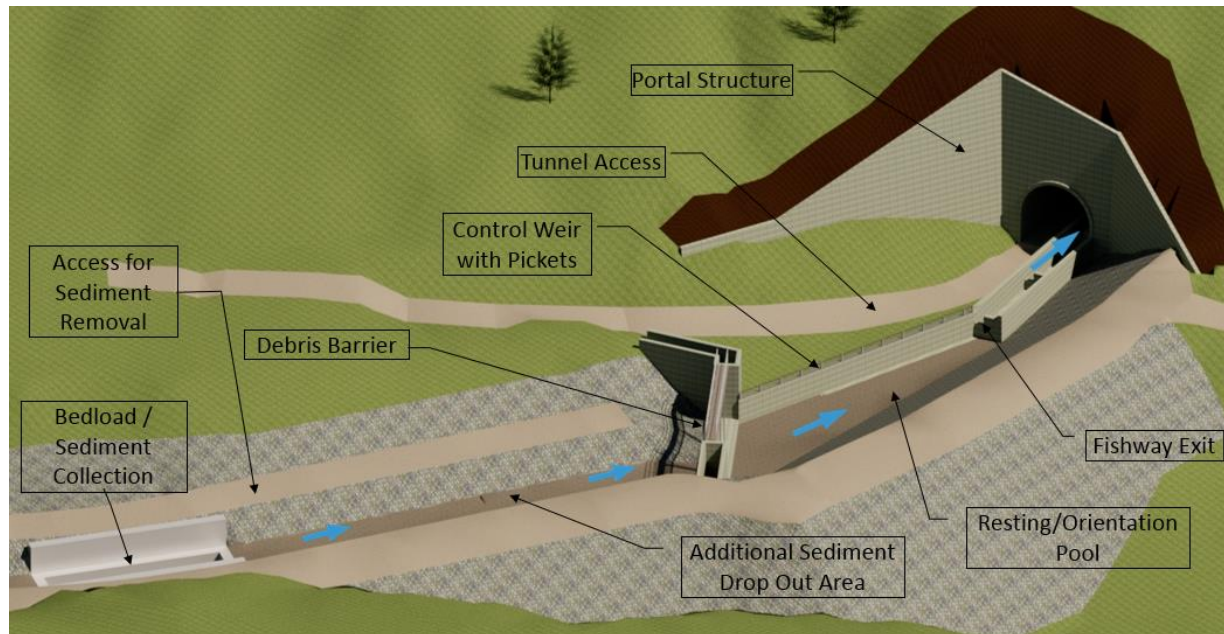

Figure 2-1. An isometric illustration of the south portal section of the EFSFSR tunnel

Blue arrows indicate direction of streamflow

2.2.1.1 Primary Sediment Trap/Resting Pool

The primary sediment trap is a deep pool just upstream from the sediment drop out channel and is intended to provide a collection sump for larger diameter particles (Figure 2-2). The sediment trap is 40 feet long by 12 feet wide. Water depth in the sediment trap would vary with streamflow and sediment accumulation. Assuming a clean trap and 54 cubic feet per second (cfs), water depth would be 10.8 feet with an average velocity of 1.8 feet per second. The primary sediment trap provides a secondary benefit as a resting pool for migrating fish before they enter the steeper, native river channel upstream.

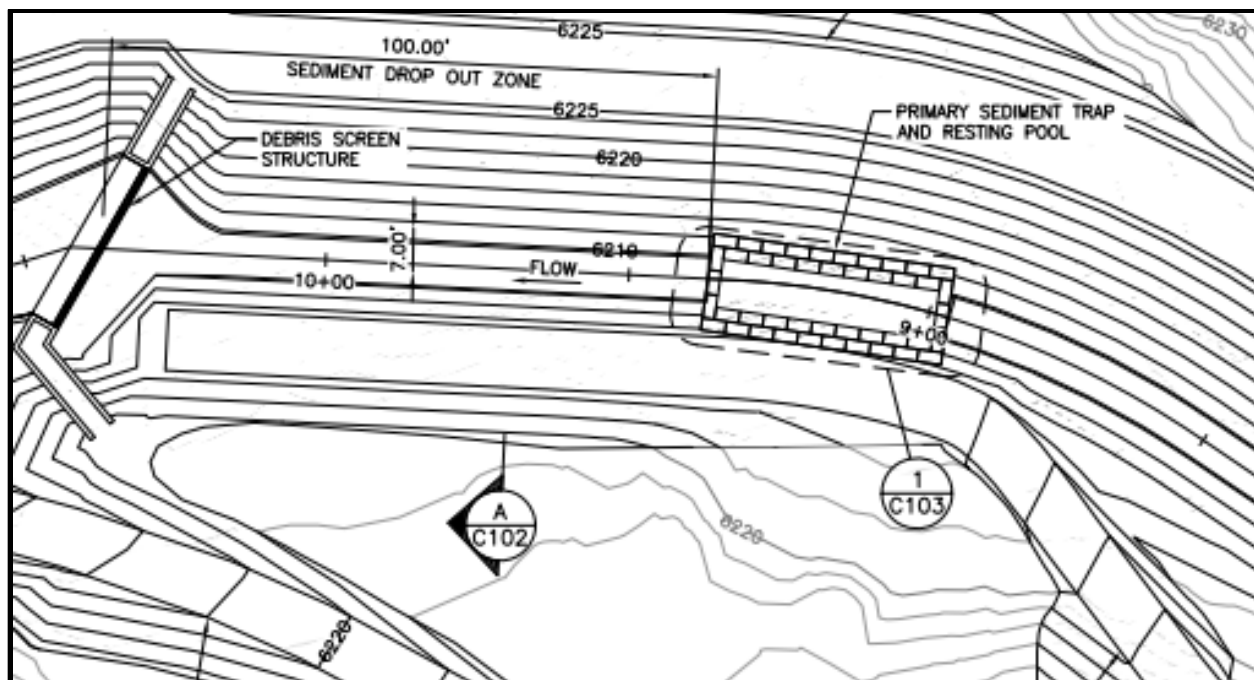

Figure 2-2. Primary sediment trap and sediment drop out zone located upstream of the debris screen

2.2.1.2 Sediment Collection Channel/Drop Out Zone

The sediment collection channel aids in preventing large amounts of bedload from entering the tunnel and potentially creating a blockage or compromising fishway hydraulics. The sediment collection channel is a 100-foot-long channel at a 0.1 percent slope (Figure 2-2). The drop out zone is located just downstream of the primary sediment trap. The channel geometry and gradient reduce stream velocities, allowing bedload sediment to accumulate within the channel. At the 500-year design flow the channel will effectively accumulate bedload 3 inches and larger. The 100-foot length of the drop out zone represents a factor of safety of approximately 7.4 versus the length required to settle 3-inch or larger bedload. It is anticipated that finer material will also be collected within the channel, particularly at flows less than the design flow.

2.2.1.3 Debris Rack

The purpose of the debris rack (or debris screen) is to prevent large floating wood and debris from entering the tunnel and potentially creating a blockage. The debris rack is angled at 45 degrees to the sediment collection channel (Figure 2-3). The angle allows the debris to be directed toward the left bank (looking downstream) for collection and removal during maintenance. The debris rack will be constructed of galvanized steel and will slide into guides between the abutments. There will be three sections along the length of the debris rack.

The debris rack must allow fish passage during the migration period. The 2-foot-high lower section of the debris rack will consist of steel bars set at 10-inch clear spacing per NMFS criteria for upstream passage of adult Chinook salmon (Figure 2-4). The upper section will extend an additional 8 feet and will consist of a bar rack with 5-inch clear spacing to capture smaller debris during higher flows. During lower flows, it is anticipated that woody debris movement will be minimal, and the tunnel will be accessible to remove any potential debris that has passed the debris rack.

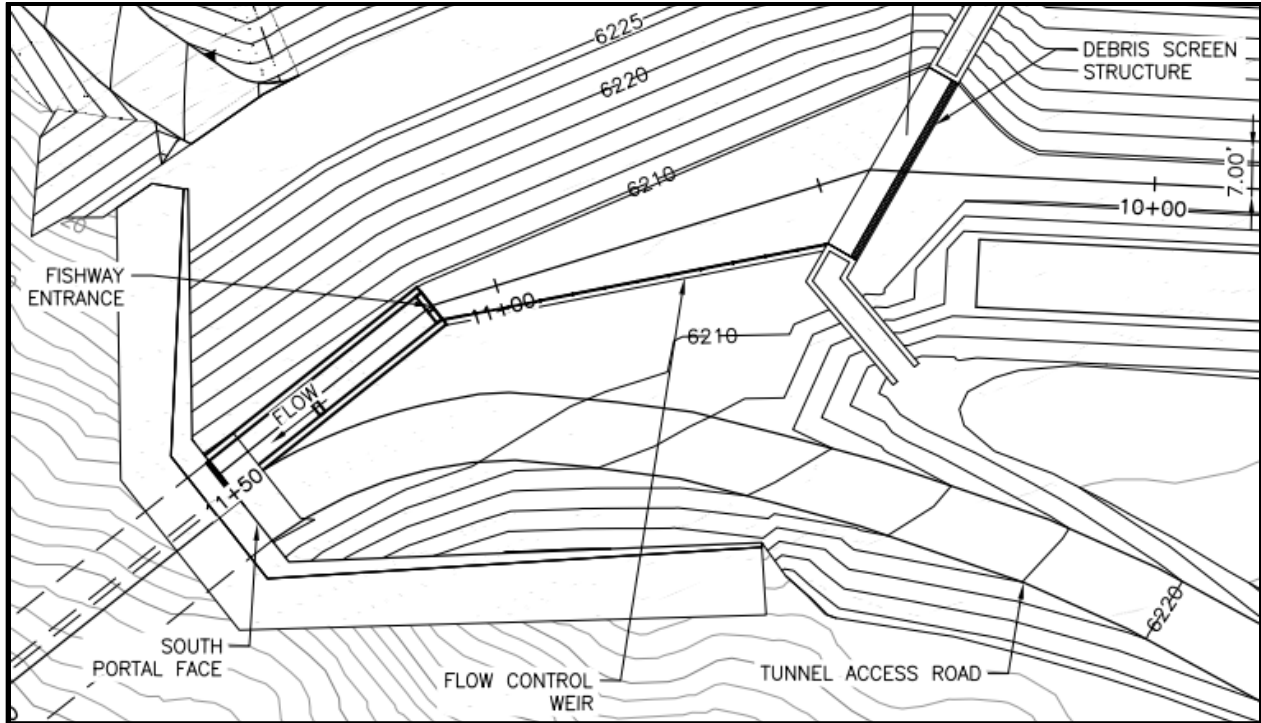

Figure 2-3. The debris screen structure is located just upstream from the flow control weir and functions to collect large wood and debris from the stream before the streamflow enters the fishway

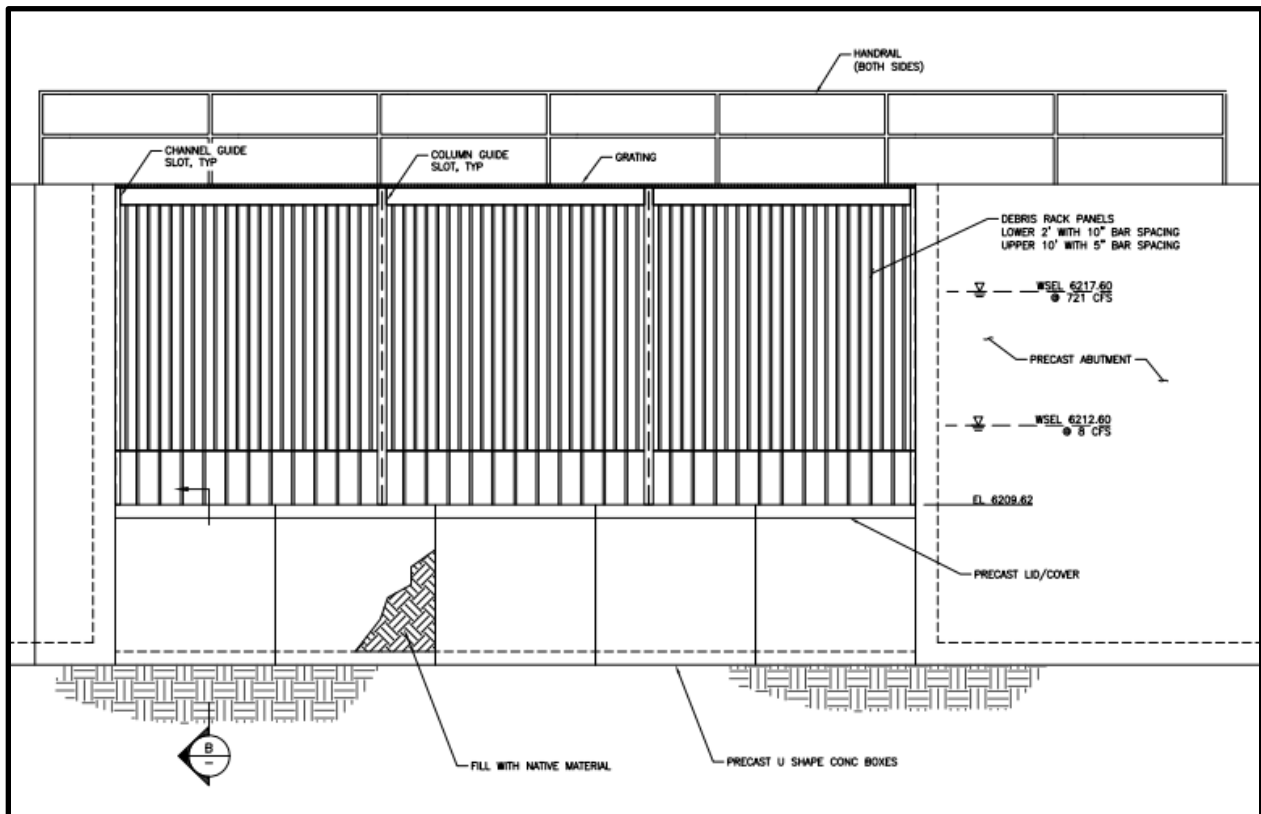

Figure 2-4. Debris screen displaying debris rack panels and upper and lower bar spacing

2.2.1.4 Flow Control Weir and Picket Panels

The purpose of the flow control weir is to direct higher flows down the accessway, while maintaining relatively constant streamflows down the fishway over a wide range of incoming river flow. This facilitates upstream fish passage over a wider river flow range than would be possible with an uncontrolled system. The flow control weir is connected to the downstream side of the debris rack abutment and would extend from the abutment to the divider wall of the elevated fishway channel. The flow control weir is 61.4 feet long and has 18-inch tall picket panels running along the top of the weir (Figure 2-5). The purpose of the picket panels is to prevent adult fish from falling back down through the tunnel accessway during higher streamflows. Each picket panel will be constructed of .5-inch-diameter tube at a 1-inch clear spacing per NMFS criteria (NMFS 2011). At future design stages, the picket design details will be re-evaluated to aid in deterring downstream migrants from going over the weir.

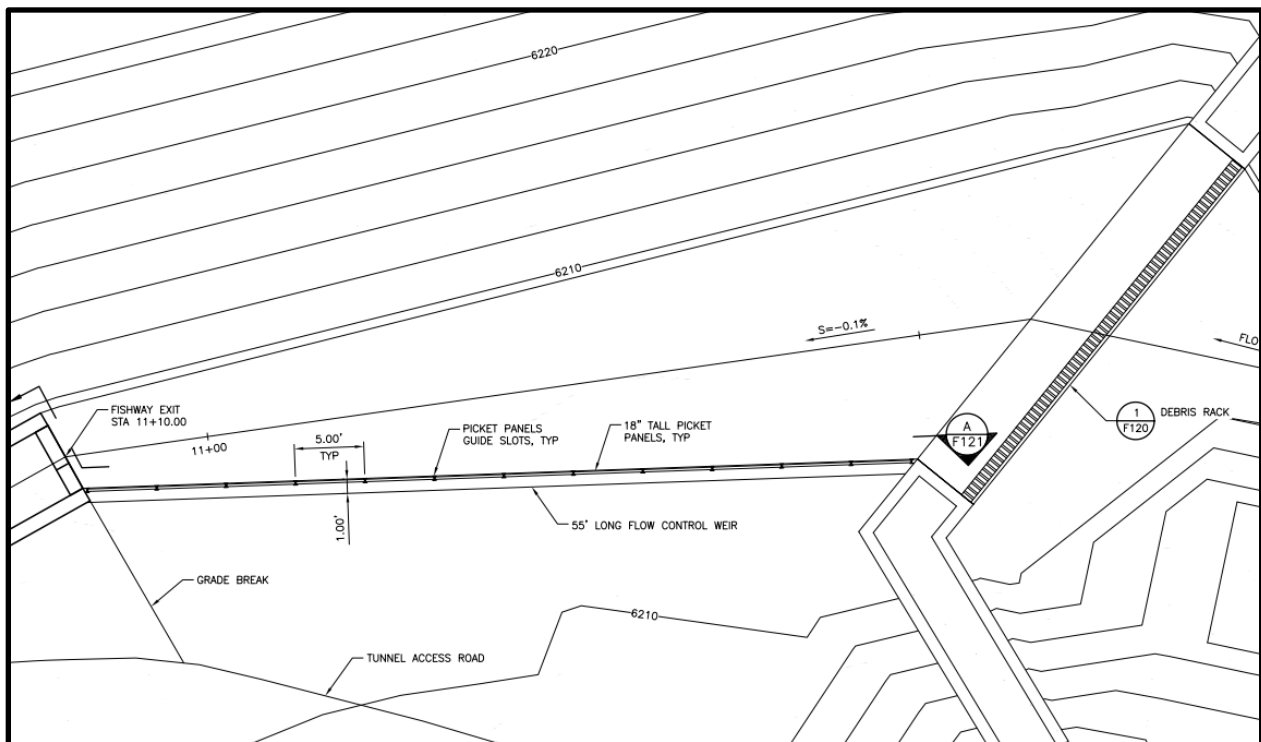

Figure 2-5. Overhead view of the flow control weir located between the debris rack and fishway

Streamflow will crest the flow control weir when total river discharge is greater than 25 cfs (Figure 2-6). The current design of the flow control weir allows for some flexibility in the height and type of picket panels deployed. That is, the picket panels are removable and can be installed just before the migration period. Each panel will be designed such that the panel can be lifted by two people from the access way. The flow control weir and adjacent channel are currently configured such that channel velocities parallel to the weir will be increasing in the downstream direction to encourage downstream migrants to enter the fishway. The pickets act as a deterrent for downstream migrants and complements the increasing velocities along the control weir to concentrate the juveniles into the fishway.

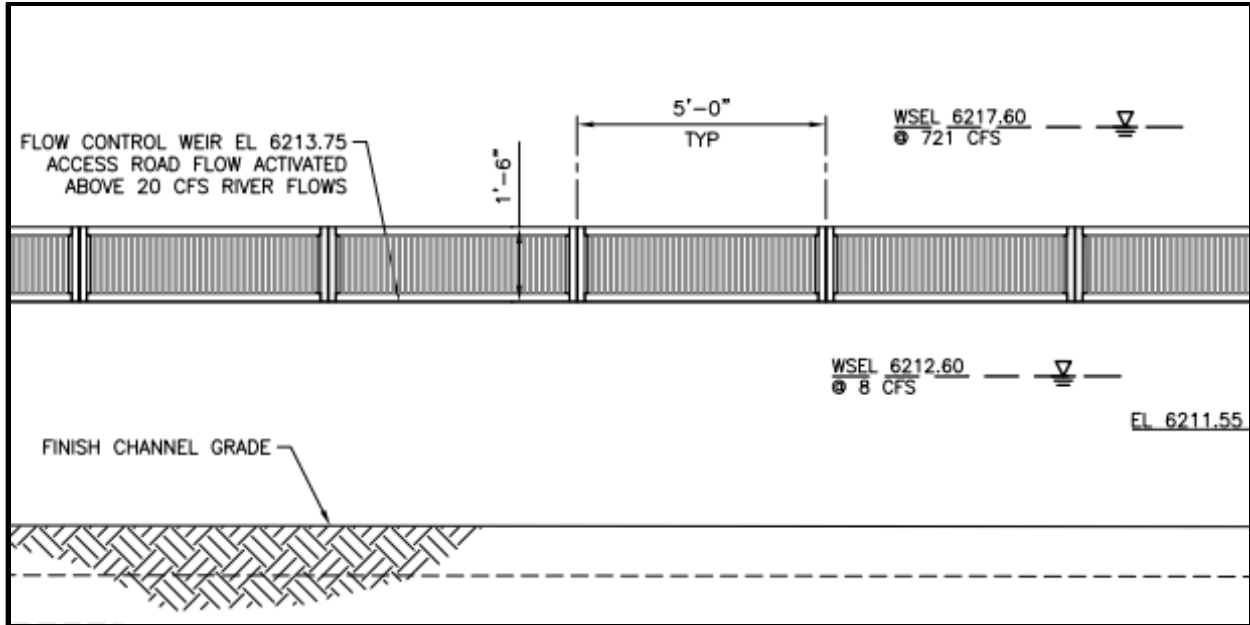

Figure 2-6. Picket panel section atop the flow control weir that would become active at streamflows greater than 25 cfs (Jensen 2019)

2.2.2 Tunnel Fishway and Accessway

The EFSFSR tunnel is divided into a fishway and accessway (Figure 10). The fishway consists of an elevated fishway channel with a concrete partition/divider wall along the length of the tunnel with intermittent weirs that provide depth and velocity control. The channel is designed to accommodate a 1-foot hydraulic drop between pools with a streaming flow over the weirs (submerged weir flow). Computational Fluid Dynamic (CFD) modeling was developed to aid in weir sizing/spacing and to confirm hydraulic performance of the proposed fish channel configuration. CFD modeling calculates that the velocities over each weir are maintained below 6.5 feet per second (fps) in all cases (i.e., throughout the fishway design flow range of 8 to 239 cfs total river flow) and the average velocity between the weirs (pool sections) is maintained below 2.0 fps.

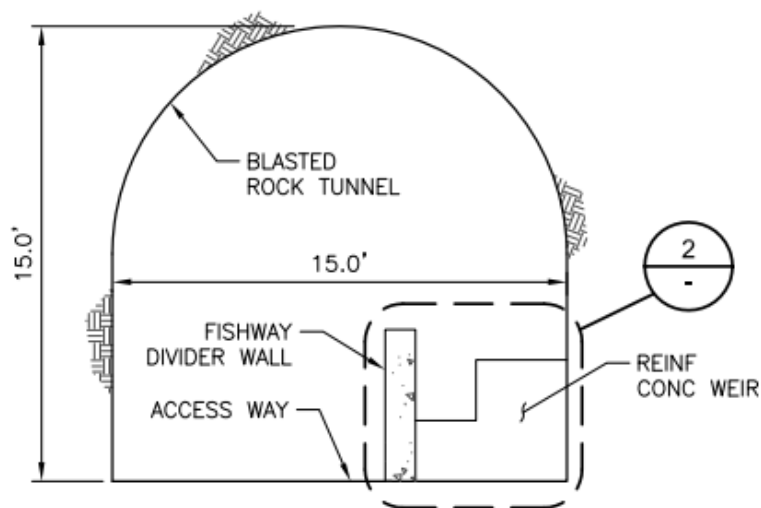

Figure 2-7. Cross-section view of the EFSFSR tunnel displaying the access way, fishway divider wall, and fishway

The isolation/divider wall will be 5 feet high and extend the length of the tunnel (Figure 2-8). The wall contains streamflow within the fishway channel and the flow control weir regulates streamflow down the accessway. Concrete weirs will be installed within the fishway to maintain the 1-foot hydraulic drop, with weir spacing dependent upon the slope of the tunnel. The weirs will be 5 feet in length with a 2.1-foot-wide weir notch 24 inches above the invert of the tunnel. The remaining 2.9 feet of each weir crest will be 4 feet above the invert of the tunnel.

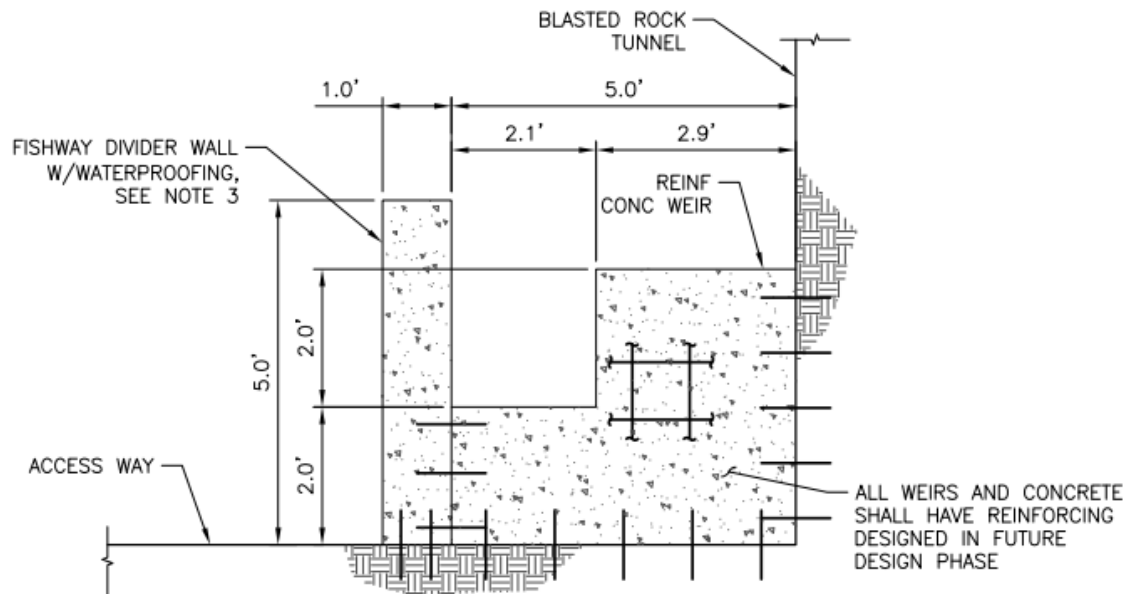

Figure 2-8. Cross-section view of the elevated fishway weir

Further CFD modeling and analysis will be completed during final design. Weir dimensions and spacings will be identified and fully detailed with reinforcement and anchoring to the tunnel floor and walls during future design phases.

A 9-foot wide accessway will run the length of the tunnel parallel with the fishway. The accessway (or access road) will allow for inspection and maintenance of the tunnel as well as the fishway. Muck bays within the accessway are alcoves built into the side of the tunnel utilized during tunnel construction to aid in efficient removal of blasted rock. These bays will be sloped to drain towards the accessway upon tunnel completion to prevent the formation of pools that may potentially delay or strand juvenile fish that enter the accessway during high-water events. The accessway itself will follow the gradient of the tunnel floor at a slope of 1.5 percent or steeper from south (upstream) to north (downstream), thereby avoiding pools or sections of adverse gradient that could delay or strand out-migrating juveniles.

2.2.3 Tunnel Lighting

Tunnel lighting will be included along the length of the tunnel ceiling, consisting of LED lights on a dimming system. From research of existing data on fish passage in tunnels, it is unclear if lighting is a benefit or not; however, there is strong evidence that abrupt lighting transitions should be avoided (Barrett 2018). Lighting will be provided to determine if it aids in fish passage and to provide light for tunnel and fishway inspections. The system would be configured so that it mimics the photoperiod of the region and runs manually, on a dimming system, or can be completely turned off at the option of the operator.

2.2.4 North Portal Area

The north portal is located at the downstream end of the EFSFSR tunnel (Figure 12). Each component of the north portal is discussed in a downstream direction in the following paragraphs.

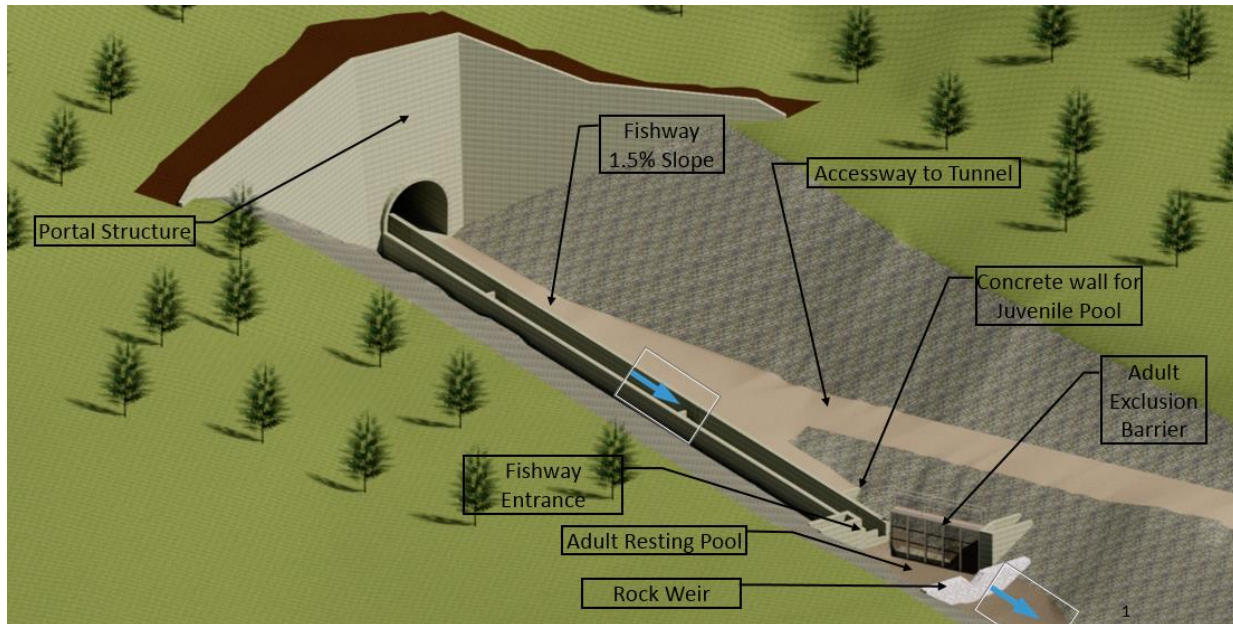

Figure 2-9. Isometric illustration of the north portal section of the EFSFSR tunnel

Blue arrows indicate direction of streamflow down the fishway to the rock weir.

2.2.4.1 Juvenile Orientation Pool

The purpose of the juvenile orientation pool is to provide juvenile fish that move down the accessway a location to rest and orient themselves prior to migrating downstream. The juvenile orientation pool is located at the end of the accessway and is upstream of the exclusion barrier. This area is backwatered by a rock weir that creates a pool that extends from the weir up to the concrete wall at the end of the accessway and encompasses the exclusion barrier. This pool is designed to be 3 to 4 feet deep with low velocities. The exclusion barrier, discussed below, prevents larger predatory fish from accessing this pool.

2.2.4.2 Exclusion Barrier

The purpose of the exclusion barrier is to prevent large fish from entering the juvenile orientation pool or accessway and to guide adult fish toward the fishway entrance. A precast concrete box sill will be placed at a 45-degree angle to the channel and will connect to the partition wall of the fishway at the fishway entrance. Steel columns will be placed along the concrete sill for access and installation of aluminum picket panels. The panels will be submerged a minimum of 3 feet. The flow entering the pool from the accessway will flow through the exclusion panels. The velocity through the gross area of the picket panels will be less than 1 fps per NMFS criteria.

2.2.4.3 Adult Holding Pool

An adult holding pool is located just upstream of the last rock weir and will allow adult fish an opportunity to rest before they proceed upstream to the fishway. This pool will be 3 to 4 feet deep with low velocities. The rock weir will maintain the pool elevation so that there is a hydraulic drop of 1 foot across the fishway entrance.

2.2.4.4 2.2.5.4 Rock Weirs and Transition Zone

The stream channel segment between the natural EFSFSR channel and the exclusion barrier will be a formed transitional channel with rock weirs (Figure 2-10). The transition channel from the fishway to the EFSFSR will consist of a trapezoidal channel with 1.5H:1V side slopes. The channel is designed to accommodate peak 500-year flood flows of 721 cfs and peak velocity of up to 17 fps without erosion. Fishway depth and velocity requirements for the north transition channel will be addressed by the rock weirs discussed above. Rock weirs will be spaced at approximately 66-foot intervals downstream of the exclusion barrier in the transition zone between the EFSFSR and the fishway entrance. The hydraulic drop across each weir will be 1 foot. The weirs are to provide a natural type passage weir within this reach.

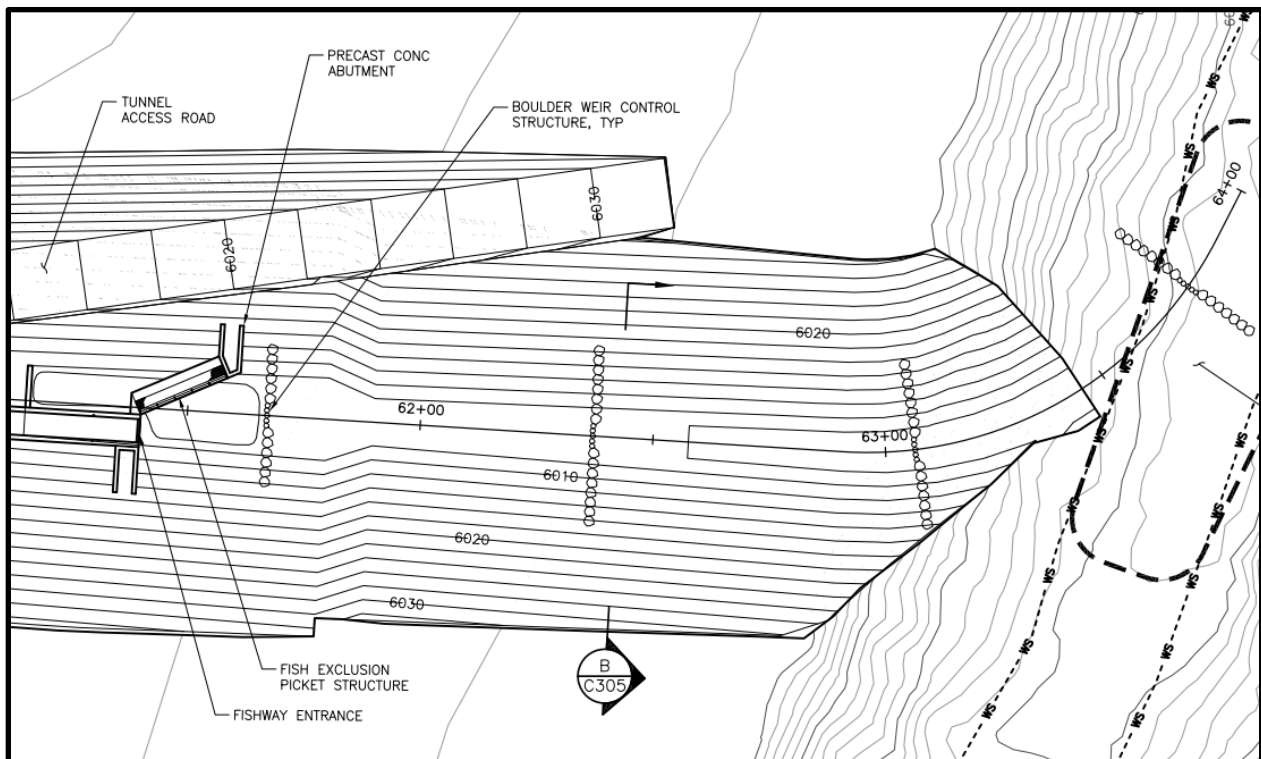

Figure 2-10. North portal area displaying boulder weir control structures that extend from the fishway entrance to natural stream channel

Section 3

Operations and Maintenance

This section outlines the anticipated operation and maintenance requirements for the project (McMillen Jacobs 2018). The information presented within this section is intended to summarize the project operation and serve as the basis for developing detailed operation and maintenance manuals in future design phases. Appropriate documentation and reporting requirements would be integrated into the plan.

3.1 Initial Startup and Testing

Initial fishway operations and inspections will begin in year 1 of the proposed 15-year operational period when the EFSFSR is fully diverted into the tunnel. The initial startup inspection will be comprehensive with engineers, fish biologists, and agency representatives. Major elements (i.e., trash rack, screens, sediment traps, entrance, and exit) of the facility would be inspected prior to diverting any flow. During the inspection, trap and haul components will be made available and be on site prior to diverting water into the tunnel. Once dry inspection and verification of trap and haul components are complete, the initial diversion will commence during the low flow period. As the water begins to flow down the channel and through the fishway, inspections and observations would be ongoing. Once flows reach a steady state within the system, velocity measurements would be taken. The velocities would be evaluated against design assumptions and create a baseline set of velocity measurements. The measurements with full diversion and watering of the tunnel are to ensure that operations will be within confidence intervals of the established design and operational criteria (NMFS 2011; McMillen Jacobs 2018). All biological monitoring and trap and haul equipment would be pre-tested and poised for activation.

3.2 Surface Conveyance Inspection and Maintenance

Project operations and maintenance will be performed on a set schedule and all observations formally documented from each inspection. Project inspections should be scheduled at the same time each year in the fall when flows drop below 20 cfs and are fully contained within the fishway. Inspection elements are described in the following subsections in an upstream to downstream sequence.

3.2.1 Primary Sediment Trap and Sediment Dropout Reach

Bedload within the sediment traps will require removal and disposal by Midas Gold personnel at least once a year. Monitoring after extreme events will be necessary to ensure that the capacity of the channel is not exceeded and may require additional removal efforts. The plan is to have the combined capacity of the sediment traps available prior to spring runoff. Estimates of potential sediment delivery are presented in Appendix B. Trap cleanout in late summer would discourage any adult salmon from spawning in the sediment basin and prevent juveniles from overwintering in the available substrate interstices.

The upstream sediment/resting pool will be inspected and photo-documented and estimates of sediment buildup noted. This estimated sediment volume will be compared to the previous inspection to get an indication of sediment delivery to the pool. Recommendations for sediment

cleanout will be included in the inspection log. If excessive sediment has accumulated within the pool, sediment cleanout will be scheduled concurrent with inspection activities.

The primary sediment trap and dropout reach would be cleared with a 230-class excavator or similar, fitted with a long-reach boom and smooth bucket to excavate from the south access road and swing directly into 10-cubic yard (cy) trucks. Assuming a sediment disposal area is located within three miles and utilizing three trucks to maximize removal productivity and assuming two trips per truck per hour, approximately 13 tons per load will be removed. Hourly productivity is approximately 6 loads per hour, resulting in 78 tons per hour. Removal of the annual bedload total of 290 tons would take approximately four hours. Allowing for mobilization/demobilization of equipment from elsewhere on the mine site, installation and removal of sediment controls, and fish salvage (if necessary), the entire sediment removal operation could be performed in fewer than three work shifts, and possibly in a single shift. Greater than average year sediment accumulations would require more frequent or longer-duration operations.

The dropout reach will also be inspected for sediment and debris buildup that may impede unrestricted flow. Quantity of sediment in the channel will be estimated by measuring the top of the sediment surface by wading/transit to estimate the distribution and extent of sediment buildup. Channel capacity will be assessed and any significant changes that may impact flow characteristics will be noted with recommendations for remedial measures. The need for sediment removal will be assessed and, if required, sediment removal will be performed concurrent with inspection activities. Sediment removal is envisioned as excavation with a smooth-faced bucket, taking care to avoid damage to the existing channel bottom reinforcement. If sediment removal is performed, the channel will be re-surveyed to document the amount of sediment removed and the final excavated configuration. The channel reinforcement will be inspected, with any areas of damaged channel lining documented. The sediment will be loaded directly into dump trucks and transferred to a designated sediment handling/storage area as specified in a future project operations plan.

Sediment delivery will be highly variable and primarily dependent on snowmelt and storm runoff rates and any fires that may occur within the contributing watershed. The sediment removal trigger is associated with a measured level of sediment buildup, still to be specified. The primary drop out area can hold approximately 3,952 cubic feet of material which equates to approximately 217 tons of sediment. The dropout reach would hold approximately 7,250 cubic feet (cf) which equates to 399 tons of sediment. This is assuming the bulk density of material is 110 pounds per cf, implying that sand infills the spaces between larger particles. Bedload discharge estimates for the SFSR basin equate to approximately 290 tons in an average year at the tunnel portal (see Appendix B). The volume available in the primary trap and dropout areas combined provides a factor of safety of approximately two versus the expected annual bedload yield. In a higher than average runoff year, the trap would be cleaned more frequently.

3.2.2 South Channel Debris Rack

Access to the left abutment of the debris rack will allow for debris removal as well as removal of sediment from the sediment collection channel. If the debris rack is damaged during high flows, the rack would be lifted out with a large excavator or crane and replaced with another section of bar rack. The size of each bar rack panel will be designed to accommodate the standard equipment utilized on the project.

The extent of debris buildup on the rack will be photo-documented prior to debris removal. The condition of the racks, supporting structure, wingwalls, and base will be noted. Any conditions that require repair will be immediately noted and specific repair methods developed and included in the inspection report. If additional inspection is required, this will be scheduled with appropriate

resources. Debris rack operation will be tested annually. Each rack will be test-lifted to assess for binding within the rack frame or any distortion of the rack panels. Rack operability will be documented, and recommendations included in the report.

The current expectation is that debris removal (e.g., trash rack and screens) would be heaviest during spring runoff which may require daily inspection and debris removal. Heavy or large debris would be removed with mechanical assistance while smaller debris would be removed by hand or brush. Some floating plant debris is expected during windstorms and with the onset of fall. Debris from the trash rack and screens will be stockpiled on site and would be removed periodically for use in stream restoration and for developing growth media. Ice buildup during the winter will be removed to prevent ice dam formation.

3.2.3 Fishway Entry Features

The access road will allow for inspection and maintenance of the tunnel as well as the fishway. The tunnel portal and sediment removal access roads are intended to provide an unpaved, durable traveling surface for standard-duty maintenance vehicles and intermittent use by 8- to 10-cubic-yard haul trucks for regular cleaning and operations. Width of road varies by location and constrictions from other project features. For areas outside the waterway, typical road width was established at 20 feet. Access roads below the flood level of the EFSFSR may be narrower. Road surface treatments below flood elevation would be 4-inch-thick concrete-filled Geoweb™. Road surface treatment above flood elevation would 12-inch-thick layer of 6-inch D50 aggregate base to provide roadway armoring.

3.3 Tunnel Portals

The inspection of the north and south tunnel portals will include a thorough assessment of overall portal face stability, with specific attention to signs of excessive rockfall; evidence of soil movement such as soil creep, cracking, slumping, or soil relaxation around soil nails; shotcrete distress including cracking or bulging; excessive seepage or discharge from specific portal areas; and any notable change to the physical condition of the portal face. Recommendations for any stability enhancement or mitigation measures will be included with each inspection, noting severity and timing for implementation of remedial measures. Any need for additional evaluation will also be noted.

3.4 Tunnel

Within the tunnel, inspections will document tunnel crown and sidewall conditions with respect to rock block stability, joint widths, groundwater inflows, and sediment buildup. Crown block stability is the primary concern. Any sign of potential weakness that could lead to tunnel collapse will be fully documented with recommendations to address any observed or suspected conditions. The tunnel invert will be inspected for signs of excessive erosion, instability, or heave. Vehicular travel must be maintained along the accessway for inspection and routine maintenance of the tunnel and fishway channel.

3.5 Fishway Channel

The fishway channel features will be inspected for any signs of cracking or tilting of the fishway divider wall or weir structures. Cracking or offset of any of the concrete structures will be measured, photographed, and documented with recommendations for remedial measures, if any. Sediment buildup and levels will be noted in front of each weir structure and compared to sediment levels from the last inspection. Any sediment volume or configuration that affects fishway flow will be noted and

recommendations for sediment removal put forth and scheduled as needed. Sediment buildup trends will be noted and a plan for sediment removal will be developed and scheduled, if needed.

At this point in the design, it is assumed that sediment removal from the fishway will be accomplished by mobile vacuum truck or other hand methods. Weir connections to the tunnel wall and divider wall will be inspected and any cracking or pullout of anchoring elements will be noted with condition, severity, and plans for repair included on the inspection record. The divider wall will be marked with specific stationing for reference and each weir will be given a unique designation for reference.

3.6 North Channel Fishway Features

The fish channel entry area will be photo documented. Any obstructions will be noted, stoplog slots will be inspected, and effective flow conditions through the fishway will be verified. The downstream weir and picket panel assemblies will be inspected, and any required repairs documented. The condition of the weir concrete and any sediment buildup will be documented with recommendations for repair or removal. A picket panel removal check will be performed for each panel and each panel will be checked for effective return to each slot base.

3.7 North Channel to EFSFSR Confluence

The north channel will be inspected down to the confluence with the EFSFSR. Boulder weir pool structures will be noted with respect to functionality or change since the last inspection. The downstream access road conditions will be noted to confirm access to the downstream resting pool. Conditions at the pool will be inspected and the need for additional pool excavation determined. Overall, bank conditions that indicate any sign of instability or excessive erosion that could impact access will be noted, classified in terms of urgency to address, and remedial actions planned and implemented, as needed. The intent is that the channel itself will not require active cleanout or maintenance during the operational life. Heavy equipment access is not included in the channel armoring/support criteria because the channel should self-maintain with seasonal flow cycles. In fact, there is a possibility that the spawning fish may establish redds in this channel. If this occurs, active channel maintenance activity will likely be prohibited.

3.8 Fish Monitoring Instrumentation

PIT arrays and video equipment will be monitored throughout the migration period. Data collected will be downloaded and compiled for review. During final design, the installation method will be determined in conjunction with the PIT tag array supplier. Elevated platforms will be required to mount the monitoring equipment to prevent water damage during high flow events. Monitoring equipment will be maintained as needed to provide fish passage indices (see Section 4 Monitoring, Evaluation, and Adaptive Management).

3.9 Tunnel Lighting

Lighting will be utilized during tunnel inspections and fishway maintenance. Lighting will be monitored, and bulbs/LED elements replaced as required prior to the migration period. Variable or transitional lighting controls will be manually checked, and any automated systems may require inspection coincident with changes in ambient outdoor lighting to verify that the portal circuits are functioning properly.

3.10 Fishway Inspection

Fishway operations and maintenance would include a series of regularly scheduled duties. The performance of those duties could vary if the fishway is operated in a volitional passage mode compared to a trap and haul passage mode. In either passage mode, routine operations and maintenance would include the following:

- Inspect and remove debris from trash racks and screens (previously discussed).
- Inspect and remove bedload as needed from sediment traps (previously discussed).
- Inspect, clean, and remove fine sediments and small debris from fishway.
- Inspect, adjust, and record entrance hydraulic conditions.
- In trap and haul passage mode, capture, transport and release fish upstream.
- Inspect and adjust monitoring devices and download monitoring data⁷.
- Review and report monitoring data.
- Identify and summarize maintenance needs.
- Perform required or identified maintenance.
- Fishway inspections with agency personnel.

Small amounts of finer sediment (sand and small gravel) or organic debris may accumulate in the fishway, particularly the first few pools from the south portal. Areas of debris and/or fine sediment buildup would be noted with routine fishway inspections. These areas would be cleaned out with regularly scheduled maintenance. Maintenance for the fishway inside the tunnel would be accomplished with a vac truck to remove sediment between weirs.

It has been initially estimated that it will take approximately three days to clean out the fishway pools on average years given the following assumptions:

- There will be 1 foot of sediment in each pool, roughly 25 feet long and 5 feet wide per pool.
- Velocities in the fishway are anticipated to keep fines (silts) suspended and flushed through the system.
- The initial 5 to 20 pools would accumulate the sand and small gravel that would be mobilized during high flow events.
- The volume equates to 125 cf per pool.
- Assuming the vac truck has 6 cy capacity, approximately 1.25 pools could be cleaned per load. At 1.5 hours per load to fill the vac truck, transport to the sediment disposal site and return to the tunnel, 16 vac truck cycles are required to clean 20 pools that are full of sediment.

3.11 Trap and Haul

The design of the fishway incorporates a trap and haul function for potential use if monitoring results indicate that the fishway is not meeting passage standards. At the north portal, the entrance pool for the fishway (first pool) was adapted to function as a fish trap. To initiate the trapping process, a picket panel will be installed into guide slots that have been placed in the fishway walls. The picket panel will extend the full width of the pool. The panel will completely block the fishway pool and extend above the water surface up to the same height as the fishway walls. With the panel in place, fish will be collected and held in the first pool.

⁷ How often monitoring data (i.e., PIT tag and video footage) would be downloaded depends on data transfer technology, data storage capacity, and activity at the monitoring stations.

To initiate collection of the fish, another picket panel will be placed into guide slots at the downstream end of the pool, upstream from the fishway entrance. This will prevent fish from escaping back out the entrance during collection. Manual crowding panels will be designed to fit within the pool width for crowding fish to the upstream end. The fish would be manually netted out of the pool and placed into a transport vehicle parked on the adjacent accessway. Any additional tagging or fish evaluation could be accommodated at this time. During high flows, access to adult trapping would be accomplished via the walkway on top of exclusion barrier. Trap and haul fish would be released in a pool upstream of the EFSFSR tunnel.

3.12 Entrainment and Fish Salvage

Fish salvage operations would be expected any time the facility needs repair within the fishway, potentially during sediment removal, and potentially when streamflows recede from the accessway. Temporary dewatering for repair or sediment removal would most likely occur during base streamflows and would follow instream water work window recommendations of the Upper Salmon Basin Water Project Technical Team (USBWP 2005). Additional fish protection measures have been submitted for fish handling and salvage (BC 2019a).

Streamflows and hydraulic conditions within the fishway would be similar over a wide range of streamflows. Thus, the need for fish salvage will be limited with typical operations. However, the accessway will naturally water up at least once each year as streamflow exceeds 25 cfs (Figure 3-1). The accessway will also naturally dewater gradually each year when streamflows recede from the flow control weir. Based on average conditions, mid-April (April 17) and late July (July 30) are the approximate dates when streamflow would crest and then recede from the flow control weir, respectively. Based on those dates, the accessway would remain inundated for about 105 days out of the year.

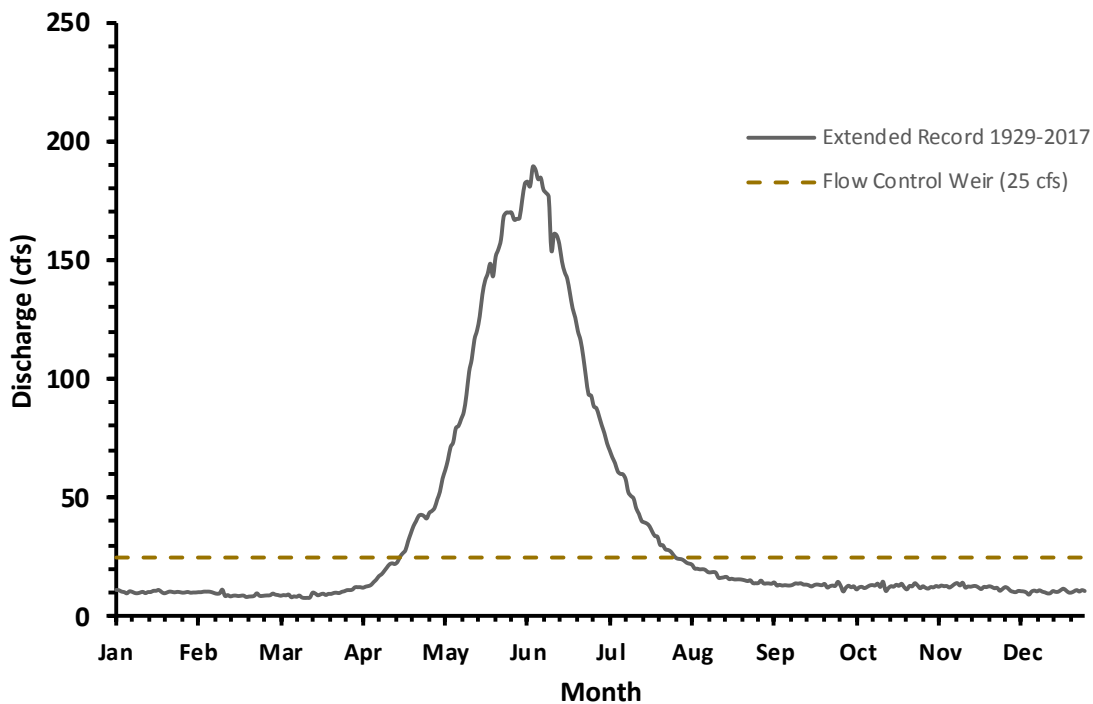

Figure 3-1. Average daily flows in the EFSFSR at the North Portal of the proposed tunnel for the period 1929-2017 (from Rio ASE 2019). A dashed line represents the 25 cfs flow necessary to crest the flow control weir.

Streamflows approaching 25 cfs would signal a potential period when fish traveling down the accessway are most vulnerable to shallow water depths within the accessway. NMFS (2011) provides guidance for minimum water depth at the low fish passage design flow for culverts. That guidance stipulates 1.0 feet for adult steelhead and salmon, and 0.5 feet for juvenile salmon. The accessway would not meet this culvert water depth criterion at total streamflows approaching 54 cfs. For example, water depth in two sections of the accessway at 25.6 cfs, which is the accessway flow when the river is discharging 54 cfs, would be 0.3 feet deep within the steep slope section and 0.4 feet deep in the shallow slope section. However, when these conditions are present, the flow depth over the control weir is only 1.6 inches, making the likelihood of juvenile entrainment in the accessway quite small.

As outlined in the goals and objectives of Fisheries and Aquatic Resource Mitigation Plan, water infrastructure will be managed to protect fish and minimize harm by implementing best practices for diversions, dewatering, isolation and fish salvage (BC 2019a). Receding streamflows within the accessway would signal potential inspection and fish salvage. Prior to inspection, the accessway would remain flowing for a period by mechanical or gravity means to continue flushing fish downstream. This preventative measure provides streamflow down the accessway while no new fish enter the accessway. Only when the inspection is complete would supplementary flow be removed. If juvenile fish need to be salvaged within the accessway, they would be hand-netted and immediately release within the fishway.

3.13 Tunnel/Fishway Decommissioning

The tunnel and fishway would be fully decommissioned in year 15 and the EFSFSR would flow through a reestablished stream channel where the YPP formerly existed. The restored stream channel would receive incremental streamflow increases (year 12) prior to full dewatering of the tunnel (Rio ASE 2019). This would facilitate watering of the new stream channel and riparian zone and minimize fish salvage needed for the tunnel⁸. Biological monitoring equipment would be removed from the tunnel and all recorded data would be tabulated and reported as necessary. Lack of fish presence within the tunnel would be confirmed with a final physical inspection before the tunnel is fully dewatered.

Although the tunnel will be deactivated, it could be used strategically to manage streamflow through the newly reestablished stream channel. That is, some portion of high flow may be diverted down the tunnel to avoid damage to stream channels and riparian areas. Tunnel and fishway inspection would continue during the period (2-years) when the tunnel may be used adaptively to moderate high flows.

⁸ The channel would be fully “watered up” before fish would be allowed to colonize or migrate through the restored stream channel. Fish would then be diverted into the new stream channel prior to decommissioning the tunnel. This would minimize fish handling and salvage operations within the tunnel when it is finally dewatered.

Section 4

Monitoring, Evaluation, and Adaptive Management

This section describes the how the hydraulic conditions, fish use, and performance of the tunnel fishway will be measured and evaluated, the design of the adaptive management component of the plan, and plan for its implementation.

4.1 Adaptive Management Approach

In its decision framework and monitoring guidance for Adaptive Management for ESA-Listed Salmon and Steelhead Recovery, NOAA (2007) defines adaptive management as “...the process of adjusting management actions and/or directions based on new information.” Further, NOAA (2007) describes that it is essential to incorporate a plan for monitoring, evaluation, and feedback into an overall implementation plan, and that the plan should link results to feedback on design and implementation of actions. Figure 4-1 illustrates the adaptive management cycle⁹.

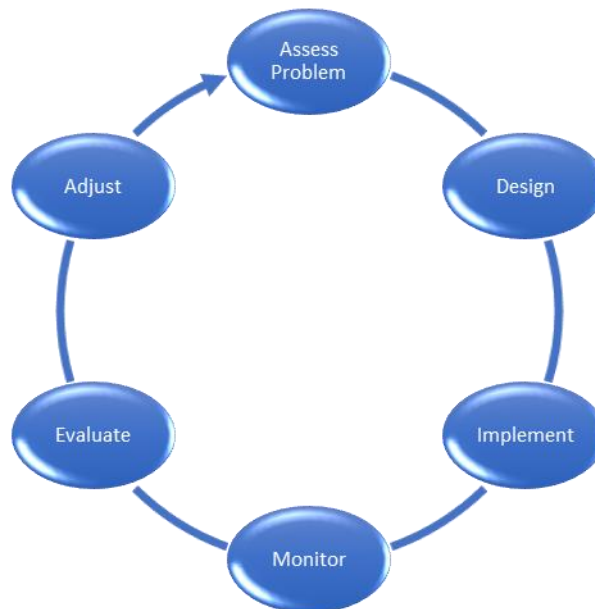

Figure 4-1. Adaptive management cycle for the EFSFSR fishway

In the case of the tunnel fishway, considerable attention has been directed toward assessing the “problem” (i.e., restore fish passage), establishing the passage goal and objectives, designing the tunnel and fishway (McMillen Jacobs 2018), and developing plans for its implementation and monitoring (Fisheries Management Plan; BC 2019a and this document). The remaining details for

⁹ Adaptive management referenced here is specific to the performance of the tunnel and fishway from a fish passage perspective. That perspective includes both adult upstream migration and juvenile emigration through the fishway.

evaluating monitoring results and making necessary adjustments are described below. Following review of this draft document by the USFS, the Services, and other agency participants, MGII will consult with these agencies to adapt and refine the specifics. This process will also provide more refined information to be included in the biological assessment for the Section 7 consultation process.

The following sections describe the proposed physical and biological monitoring proposed for the tunnel fishway. Integral to the adaptive management element of this FOMP is the development of appropriate performance standards and metrics; therefore, this section outlines proposed fishway performance measures developed from review of the literature and reports on other fishways in the Pacific Northwest and Columbia River Basin.

The adaptive management proposed herein relies on monitoring and evaluation to identify if fishway objectives are being met, determine if corrective actions are required, and establish a timeline for completion for adaptive management and maintenance actions. If the results of the monitoring program indicate that fish passage in the EFSFSR diversion is failing to achieve the performance standards as anticipated, reasons for not achieving current standards would be evaluated and corrective actions would be proposed in consultation with the Services. This consultation may result in the refinement of monitoring, performance objectives, or operations of the tunnel fishway. One of the primary adaptive management components is that the design of the tunnel fishway is the option to operate the fishway as a trap and haul facility, so that if fishway performance of other factors (e.g., stocking plans, numbers of arriving fish, etc.) dictate, upstream passage can be provided without the operation of the entire fishway.

The Adaptive Management for ESA-Listed Salmon and Steelhead Recovery report (NOAA 2007) identifies several types of monitoring. For the purposes of the tunnel fishway, the two most important are:

- **Implementation monitoring.** Implementation monitoring determines whether activities were carried out as planned and is generally carried out as an administrative review or site visit.
- **Compliance Monitoring.** Compliance monitoring determines whether specified criteria are being met as a direct result of an implemented action.
- **Effectiveness Monitoring.** Effectiveness monitoring evaluates whether the management actions achieved their direct effect or goal.

All three of these types of monitoring are proposed below. Implementation monitoring is planned for immediately after the fishway construction as part of the construction and during initial operation to determine that the fishway is operating within design parameters.

4.2 Fishway Monitoring and Evaluation

4.2.1 Camera/Video Monitoring

Midas Gold, Inc. is considering both aerial and underwater remote camera systems as part of the overall fishway and biological monitoring plan for the facility. Cameras placed at the north and south portal areas would allow personnel from the mine administrative offices to observe important facility components (i.e., debris rack, flow control weir, sediment traps, staff gauges or water level indicators, etc.). Fishway entrance and exit conditions could be monitored remotely. This level of monitoring adds a margin of safety and security for the tunnel and fishway.

Recorded underwater video footage would allow personnel to review fish movement and tabulate adult passage as part of the biological monitoring plan. Recorded video from the fishway entrance and exit would be reviewed for adult fish passage. In addition, underwater video cameras stationed

at the fishway entrance and adult holding pool would be ideal for observing entrance and approach behavior at those locations. Underwater video footage can be viewed at higher than normal speeds to concentrate on periods of adult fish passage. Alternatively, there are several commercially available fish monitoring systems that use infrared detection and motion-activated video for monitoring that avoids the long hours of video review to accomplish data reduction (Travade et al 2002; FERC 2004; Washburn et al. 2008; Baumgartner et al. 2010).



Figure 4-2. Screen image from a motion-activated fishway monitoring system

Source: Travade et al. (2002)

Recording adult fish passage against a contrasting background would provide better conditions for enumerating adults. Lighting would be employed to enhance fish recognition and counts during low light conditions. Adult fish counts can be tabulated on predefined forms summarizing the station, date, time, number, and species passing through the fishway.

4.2.2 Passive Integrated Transponder Tag Array

PIT tag arrays will be positioned at key monitoring points within the tunnel. It is anticipated that there would be four arrays. The first one would be placed near the north portal to the fishway (downstream end), another at a point within the tunnel where natural light becomes diminished, one at the grade break in the tunnel, and one final array at the south portal (upstream end).

The number and location of PIT detection arrays and the arrangement of the antennas will be further evaluated during final design and ongoing ESA Section 7 consultation. The current PIT tag detection array near the outlet of the YPP lake would be removed and strategically placed downstream of the EFSFSR tunnel to record fish approaching (adults) or departing (juveniles) the fishway. In combination with the PIT tag stations on the SFSSR at Guard Station Bridge and EFSFSR near Parks Creek there would be seven potential unique detection locations from which migration characteristics could be monitored.

PIT array detection will be useful for assessing travel times and migration rates of both juvenile and adult salmonids that have been previously PIT tagged. For those station located within the EFSFSR

tunnel, data would be downloaded periodically from the PIT tag stations and entered into the centralized database for the Columbia Basin PIT Tag Information System PTAGIS.

4.1.3 Fishway Inspection

Fishway inspections could largely be accomplished with the remote camera system. That is, staff gauges strategically placed at the tunnel portals would facilitate quick visual readings of depth and hydraulic drop. MGII would document required physical, hydraulic, and operational performance conditions as needed (Benner 2016). Representative measurements would be established as part of a routine fishway inspection and reporting. Fishway inspections would be performed in a systematic fashion with a checklist and paperwork to document compliance. The fishway inspection forms would be tailored to specific areas to include check marks, notes and specific measurements to document passage conditions (Towler et al. 2013). Standardized forms and checklists would provide consistency in monitoring the fishway. Table 4-1 presents fishway performance measures monitored during fishway inspection.

Table 4-1. Fishway performance measures and standards for the fishway entrance, fishway ladder, and south portal debris management.

Monitoring Type	Performance Measure	Performance Standard	Metric	Description
Compliance	Fishway Entrance	---	Head Differentials	Monitor and report fishway entrance and ladder conditions as part of routine fishway inspection. Maintain gauges throughout the fish passage season and readable at all streamflows. Debris and substrate management at south portal.
		1.5 to 4.0 fps	Transport Velocity	
		n/a	Maintain all water level indicators or gauges	
	Fishway Ladder	12 inches maximum	Hydraulic drop between fish ladder pools	
		1-ft. minimum	Flow depth over fishway overflow weirs	
		1.5 to 4.0 fps	Collection or transportation channel velocities	
		4 ft-lb/s maximum	Fish Ladder Pool Energy Dissipation Factor (EDF)	
South Portal	n/a	Debris and bedload management		

Notes:

fps = feet per second

ft-lb/s =

n/a = indicates that no specific numeric performance standards apply.

4.3 Biological Monitoring and Evaluation

There is some uncertainty regarding the number and precise timing of juvenile and adult fish that would use the EFSFSR tunnel and fishway. As part of the adaptive management program, initial monitoring and evaluation will be key to understanding those uncertainties. Establishing monitoring objectives provides a framework from which passage indices or metrics would be established.

Monitoring elements established for EFSFSR tunnel would include:

1. Monitor adult approach (downstream PIT tag station)
2. Monitor adult fishway entrance (north portal)
3. Monitor adult fishway exit (south portal)

4. Monitor adult entrance and exit times
 - a. Adult entrance and exit times (video)
 - b. PIT tagged juvenile and adult entrance and exit times
5. Document trap and haul passage, date, and time
6. Monitor adult resting pool and entrance behavior
7. Document adult passage success
8. Document fish health

Both juvenile and adult ESA-listed fish species are expected to use the EFSFSR tunnel and fishway. Monitoring the first five elements would provide information on abundance and temporal distribution of fish species approaching and passing the EFSFSR tunnel (Table 4-2). This type of monitoring does not have specific performance standards but is merely used to monitor the status of target fish species.

Monitoring element 6 provides an opportunity to assess adult behavior at the fishway entrance. There is no standard performance metric for adult behavior at the fishway entrance, but continued rejection of the fishway entrance may be indicative of poor entrance conditions.

Monitoring elements 7 and 8 would document rates of passage success and mortality or injury associated with passage. Ideally, passage success rates should be high, and mortality or injury rates should be very low. Performance standards for these objectives would be decided in consultation with the Services.

Table 4-2. Performance measures and standards for fish passage at the EFSFSR tunnel and fishway.

Monitoring Type	Performance Measure	Performance Standard	Metric	Description
Status	Abundance	n/a	Adult count	Monitor fishway exit to document the abundance of adult passage through the fishway. Fish passage counts would be specific to species. Include any trap and haul released fish for final passage counts.
	Distribution	n/a	Fishway temporal distribution	Compile fish passage by date and time to provide temporal fish passage distribution. Information compiled by date and time provide seasonal and daily passage distribution patterns.
Directed	Fish Health	TBD	Mortality, injury, and descale	Assess fish health so that safe, timely, and efficient fish passage is maintained. Encompass both potential passage routes (fishway and accessway) for juveniles.
	Passage Success	TBD	Percent Passage	Document adult passage success as the number of adults that exit the EFSFSR fishway divided by the number that enter the fishway.
	Passage Time	TBD	Migration Time	Document juvenile passage time and assess emigration rate through fishway and accessway. Passage time may vary depending on passage route and streamflow. Document adult and juvenile migration time through EFSFSR tunnel.

Notes:

n/a - Not applicable because there is no specific numeric criterion.

TBD - To be decided indicates that the performance standard needs consultation with the Services for appropriate standards.

Some initial biological sampling may be warranted for the EFSFSR fishway and accessway to assess performance and potential adverse impacts (NMFS 2011). Establishing a fish collection station at the fishway entrance would be integral to sampling both juvenile and adult migrants.

4.4 Adaptive Management Reporting and Implementation

As described above, the adaptive management proposed herein relies on monitoring and evaluation to identify if fishway objectives are being met, determine if corrective actions are required, and establish a timeline for completion for adaptive management actions. The final element of this FOMP is a framework for reporting, feedback, and decisions on adjustments to fishway operations.

Following a review of this draft FOMP, MGII will develop, in coordination with the Services, an acceptable reporting format and content to address objectives established for fish monitoring and evaluation of the EFSFSR diversion tunnel. The report would organize and assess the physical and biological monitoring results relative to the agreed-upon criteria.

An effective adaptive management plan relies on information and learning (Williams and Brown 2012). In the case of the tunnel fishway, the results of monitoring will provide the basis for learning about fishway operations performance and fish passage performance, serving as the basis for further evaluation and adjustments.

MGII envisions phased decision points that would be based on monitoring results and consultation with the Services. First, decisions about operating the fishway and whether trap and haul operation is appropriate in any given year might be appropriate. Second, decisions about specific adjustments to fishway operations based on performance. However, some learning must occur first before such decisions can be made, and learning will require the operation of the fishway for some period before adaptive adjustments can be made.

Therefore, MGII proposes two basic implementation check points. The first is an annual decision point about how the fishway should be operated each year (operate fishway or trap and haul or no operation of fishway) and for the relationship to Chinook salmon stocking in the EFSFSR to be considered. The second is a check point about specific detailed adjustments to the fishway operation. Criteria may be put into place so that if any unusual or unexpected events occur that result in adverse impacts to the species during operations, that fish passage through the fishway would be switched to trap and haul operations

MGII proposes to review with the Services annual operations after the first year of operations, and after the second year for determination of necessary fishway operational adjustments. This approach allows monitoring and performance to be addressed and decisions made with new information. Other options may be considered as well, including the timing of information sharing and operations decisions. If it is determined that pre-established performance standards may not be attainable, new standards may be developed. Midas Gold will work with regulatory agencies and other project partners to refine the details of this adaptive management element of the FOMP.

Section 5

Limitations

This document was prepared solely for Midas Gold in accordance with professional standards at the time the services were performed and in accordance with the contract between Midas Gold and Brown and Caldwell dated January 1, 2019. This document is governed by the specific scope of work authorized by Midas Gold; it is not intended to be relied upon by any other party except for regulatory authorities contemplated by the scope of work. We have relied on information or instructions provided by Midas Gold and other parties and, unless otherwise expressly indicated, have made no independent investigation as to the validity, completeness, or accuracy of such information.

Further, Brown and Caldwell makes no warranties, express or implied, with respect to this document, except for those, if any, contained in the agreement pursuant to which the document was prepared. All data, drawings, documents, or information contained in this report have been prepared exclusively for the person or entity to whom it was addressed and may not be relied upon by any other person or entity without the prior written consent of Brown and Caldwell unless otherwise provided by the Agreement pursuant to which these services were provided.

Section 6

References

- Albee, C. and R. Orme, 2011. *South Fork Salmon River and Secesh River Screw Trap Operations for 2010 Summary Report*, Prepared for Quantitative Consultants, Inc., Boise, Idaho. Report prepared by Nez Perce Tribe Department of Fisheries Resources Management in Joseph, Oregon and McCall, Idaho.
- Barrett, J and M. Miller, 2018. *Analysis of stream flows and fish passage in the EFSFSR, and implications for the design of fishway in the proposed EFSFSR tunnel*. Memo to Midas Gold Idaho, Inc. Boise, Idaho. Memo dated May 15.
- Baumgartner, L., Bettanin, M., McPherson, J., Jones, M., Zampatti, B. and Beyer, K., 2010. *Assessment of an infrared fish counter (VAKI Riverwatcher) to quantify fish migrations in the Murray-Darling Basin*, Industry & Investment NSW – Fisheries Final Report Series No. 116. Cronulla, NSW, Australia. 47pp.
- Bellerud, B. L., S. Gunkel, A. R. Hemmingsen, D. V. Buchanan, and P. J. Howell, 1997. *Bull trout life history, genetics, habitat needs, and limiting factors in central and northeast Oregon: 1996 annual report*. Bonneville Power Administration, Portland, Oregon.
- Benner, D., 2016. *Adult fishway inspections on the Columbia and Snake rivers, 2016 Annual Report*. A collaborative program of: USFWS, ODFW, WDFW, IDFG, and NOAA. Fish Passage Center, Portland, Oregon.
- Bjornn, T.C., J.P. Hunt, K.R. Tolotti, P. J. Kenlry, and R.R. Ringe, 1995. *Migration of adult Chinook salmon and steelhead past dams and through reservoirs in the lower Snake River and into tributaries – 1993*. Idaho Cooperative Fish and Wildlife Research Unit, University of Idaho, Moscow, Idaho.
- Brown and Caldwell, 2019a. *Fisheries and Aquatic Resources Mitigation Plan (FMP)*, In cooperation with Rio Applied Science and Engineering, March 2019
- Brown and Caldwell, 2019b. *2018 Yellow Pine Pit Lake Fish Sampling Summary Report*. January 11.
- Burns, D., M. Faurot, D. Hogen, M. McGee, R. Nelson, D. Olson, L. Wagoner, and Caleb Zurstadt, 2005. *Bull Trout Populations on the Payette National Forest*, USDA National Forest Service, Payette National Forest McCall, Idaho.
- Downs, C.C., D. Horan, E. Morgan-Harris, R. Jakubowski, 2006. *Spawning demographics and juvenile dispersal of an adfluvial bull trout population in Trestle Creek, Idaho*, North American Journal of Fisheries Management. 26(1). pp. 190-200.
- English, K. K., T. C. Nelson, C. Sliwinski, and J. R. Stevenson, 1998. *Assessment of passage facilities for adult sockeye, Chinook, and steelhead at Rock Island and Rocky Reach dams on the Mid-Columbia River in 1997*, Draft Report prepared for Public Utility District No. 1 of Chelan County, Wenatchee Washington.
- Federal Energy Regulatory Commission (FERC), 2004. *Evaluation of mitigation effectiveness at hydropower projects: Fish passage*, Office of Energy Projects, Division of Hydropower Administration and Compliance. Washington DC.
- Federal Highway Administration (FHWA), 2007. *Design for Fish Passage at Roadway-Stream Crossings: Synthesis Report*. U.S. Department of Transportation Publication No. FHWA-HIF-07-033, June 2007.
- Hillman, T., P. Roni, and J. O'Neal, 2016. *Effectiveness of tributary habitat enhancement projects*, Report to Bonneville Power Administration, Portland, Oregon.

- Hogen, D. M, 2002. *Spatial and temporal distribution of bull trout, Salvelinus confluentus, in the upper East Fork South Fork Salmon River watershed, Idaho*. MS thesis. Moscow, Idaho: University of Idaho, College of Graduate Studies. 200p.
- Hogen, D.M., D.L. Scarnecchia, 2006. *Distinct fluvial and adfluvial migration patterns of a relict charr, (Salvelinus confluentus), stock in a mountainous watershed, Idaho USA*. Ecology of Freshwater Fish. 15.pp. 376-387.
- Holubetz, T., 1995. *Wild steelhead studies 1993 annual report*, Idaho Department of Fish and Game, Boise, Idaho, U. S. Department of Energy, Bonneville Power Administration, Portland, Oregon, IDFG 95-44, Project No. 91-073, Contract No. DE-B179-91BP21182.
- Jensen, K., 2019. *EFSFSR fish passage tunnel - accessway hydraulics. Technical memorandum No. 11*, McMillen Jacobs Associates, Boise, Idaho. Prepared for Midas Gold, Inc. Idaho.
- Mallet, J., 1970. *A methodology study to develop evaluation criteria for wild and scenic rivers*, For: Water Resources Research Institute; University of Idaho, Moscow, Idaho.
- Midas Gold Idaho, Inc. (MGII), 2016. *Plan of Restoration and Operations, Stibnite Gold Project*. Donnelly, Idaho, September.
- Miller, M., 2018. *Periodicity of spring/summer Chinook salmon, steelhead, bull trout and Westslope cutthroat trout*, Prepared for Midas Gold Idaho, Inc. Boise, Idaho, Prepared by BioAnalysts, Boise, Idaho.
- McMillen Jacobs, 2018. *East Fork South Fork Salmon River (EFSFSR) Tunnel Design Documentation Report, Revision No. 0*, Submitted to Midas Gold Idaho, Inc. Boise, Idaho, November 20.
- MWH, 2017. *Aquatic Resources 2016 Baseline Study: Stibnite Gold Project*, Report Prepared for Midas Gold Idaho, Inc. MWH, Boise, Idaho.
- National Marine Fisheries Service, 2011. *Anadromous Salmonid Passage Facility Design*, July.
- National Oceanic and Atmospheric Administration (NOAA), 2007. *Adaptive management for ESA-listed salmon and steelhead recovery: decision framework and monitoring guidance*. NOAA, National Marine Fisheries Service, Northwest Region and Northwest Fisheries Science Center.
- Nez Perce Tribe, 2018. *Redd location and survey information for Chinook salmon and bull trout in Sugar Creek for the period 2008-2016*, Information provided (January 2018) to Midas Gold Idaho, Inc. Boise, Idaho.
- Orcutt, D.R., B.R. Pulliam, A. Arp, 1968. *Characteristics of steelhead trout redds in Idaho streams*, Transactions of the American Fisheries Society, 97(1).pp. 42-45.
- Rabe, C., D. Nelson, J. Vogel, 2006. *Johnson Creek Summer Chinook Salmon Monitoring and Evaluation Project, 1998-2005 Summary Report*, Project No. 199604300, BPA Report DOE/BP-00016450-2. 132 pages.
- Rabe, C., D. Nelson, T. Hodson, 2017. *Status and monitoring of natural and supplemented Chinook salmon in Johnson Creek, Idaho*, Annual Progress Report, Project No. 199604300, BPA report contract 74742, 112 pages.
- Rio Applied Science and Engineering (Rio ASE), 2019. *Stream Design Report, Stibnite Gold Project*, Prepared for Midas Gold Boise, Idaho. Prepared by Rio ASE, Boise, Idaho, February.
- Roni, P., T. J. Beechie, R. E. Bilby, F. E. Leonetti, M. M. Pollock, and G. R. Pess, 2002. *A review of stream restoration techniques and a hierarchical strategy for prioritizing restoration in Pacific Northwest watersheds*, North American Journal Fisheries Management. 22:1-20.
- Roni, P., K. Hanson, and T. J. Beechie, 2008. *Global review of the physical and biological effectiveness of stream habitat rehabilitation techniques*, North American Journal Fisheries Management. 28(3):856-890.
- Roni, P., G. R. Pess, T. J. Beechie, and K. M. Hanson, 2014. *Fish-habitat relationships and the effectiveness of habitat restoration*, U.S. Department of Commerce, NOAA Tech. Memo. NMFS-NWFSC 127.

- Thurow, R., 1987. *Evaluation of the South Fork Salmon River steelhead trout fishery restoration program. Period covered: March 1, 1984 to February 28, 1986.* Contract no.14-16-0001-86505. Boise, Idaho. Idaho Fish and Game.
- Towler, B., et al., 2013. *TR-2013-1 Fishway Inspection Guidelines (6/5/2013)*, Amherst, Massachusetts, University of Massachusetts Amherst, Fish Passage Technical Report. 1: 18.
- Travade, F & Larinier, Michel, 2002. *Monitoring techniques for fishways.* Bulletin Français de la Pêche et de la Pisciculture 364(326-27). Accessed at: <http://dx.doi.org/10.1051/kmae/2002101.364.10.1051/kmae/2002101>.
- U.S. Army Corps of Engineers (USACE)/Bell, Milo C., 1991. *Fisheries Handbook of Engineering Requirements and Biological Criteria.*
- Upper Salmon Basin Watershed Project Technical Team (USBWP), 2005. *Upper Salmon River recommended instream work window and fish periodicity for river reaches and tributaries above the Middle Fork Salmon River including the Middle Fork Salmon River Drainage.* Revised Nov. 30, 2005. Salmon, Idaho.
- United States Fish and Wildlife Service (USFWS), 2017. *Fish passage engineering design criteria.* USFWS, Northeast Region 5, Hadley, Massachusetts.
- Washburn, E., Gregory, J. and Clabburn, P., 2008. *Using video images for fisheries monitoring: A manual for using underwater cameras, lighting and image analysis.* Environmental Agency, United Kingdom, Science Report SC050022/SR2.
- Watry, C.B., D.L. Scarnecchia, 2008. *Adfluvial and fluvial life history variations and migratory patterns of a relict charr, Salvelinus confluentus, stock in west-central Idaho, USA,* Ecology of Freshwater Fish, 17. pp. 231-243.
- Washington Department of Fish and Wildlife (WDFW), 2013. *Water Crossing Design Guidelines.*
- Williams, B. K., and E. D. Brown, 2012. *Adaptive Management: The U.S. Department of the Interior Applications Guide.* Adaptive Management Working Group, U.S. Department of the Interior, Washington, DC.

Appendix A: EFSFSR Streamflows

Memorandum



Rio ASE 2601 W. Woodlawn Ave., Boise, Idaho 83702, Telephone: 208-866-8753

TO: GENE BOSLEY – MIDAS GOLD/IDAHO, INC.
FROM: JEFF FEALKO 
DATE: JUNE 28, 2019
FILE: 023-090-001-04
SUBJECT: DAILY AVERAGE AND EXCEEDANCE FLOWS

Daily Average Flows

Hydrology data were obtained from U.S. Geological Survey (USGS) Gage 13313000 on Johnson Creek near Yellow Pine, Idaho, for the entire period of record (1929–2017) and from USGS Gage 13311250 on the East Fork South Fork Salmon River (EFSFSR) near Stibnite, Idaho, again for the entire period of record (2011–2017) (Rio ASE 2019). The Johnson Creek gage was used to statistically extend the record at the EFSFSR gage. Specifically, long term EFSFSR average daily discharge estimates were developed by using the long term Johnson Creek daily average flow records and multiplying them by a discharge ratio of flows from the EFSFSR and Johnson Creek gage, as shown below. The average daily flow for the estimated daily exceedance flow over the desired longer period of record was then calculated (Rio ASE 2019). In effect, the longer record of flows from the Johnson Creek gage was used to adjust data from the EFSFSR site to better reflect the actual magnitude and variation of average daily flows during the estimated fish use window that would have been recorded in the EFSFSR if the gage had operated for longer than 7 years.

$$Q_{extended_{EFSFSR_{day_i}}} = Q_{por_{Johnson_{day_i}}} \frac{Q_{por_{EFSFSR_{day_i}}}}{Q_{2011-2017_{Johnson_{day_i}}}}$$

Where:

day_i = day of year for which the discharge is being calculated

EFSFSR = subscript for EFSFSR gage data

Johnson = subscript for Johnson Creek gage data

$Q_{2011-2017_{Johnson_{day_i}}}$ = average daily discharge at the Johnson Creek gage for each day_i over the years for which records at the EFSFSR gage are available (cfs; 2011–2017)

$Q_{extended_{EFSFSR_{day_i}}}$ = average daily discharge for each day_i over the desired historical timeframe (cfs)

Q_{POR} = average daily discharge for each day_i over the period of record of the respective gage (cfs; 2011–2017 for EFSFSR, 1929–2017 Johnson Creek)

The EFSFSR gage near Stibnite is close to the downstream portal (“North Portal”) of the proposed tunnel. The drainage areas for the sites differ by only 1.6 percent (24.1 and 24.5 square miles for the gage site and the North Portal, respectively). Given the proximity of the gage to the area of interest, no further adjustments were made to estimate discharge at the North Portal to establish basic fish passage design values. Future design stages may incorporate the additional adjustments along with other refinements.

Calculation of 5 and 95 Percent Exceedance Flows

National Marine Fisheries Service (NMFS) criteria specify that the design flow range for fishways should be based on the 5 and 95 percent exceedance flows over the preceding 25 years (NMFS 2011). The 5 percent exceedance flow is the stream discharge that is higher than all but 5 percent of the recorded flows during the period. The 95 percent exceedance flow is the discharge that is lower than all but 5 percent of the flows during the period.

The 5/95 percent exceedance flows were calculated for the North Portal in a similar fashion as the daily average discharge: the USGS Gage 13313000 at Johnson Creek was used to statistically extend the record of USGS Gage 13311250 on the EFSFSR. The flow data analyzed were for 1993–2017 (i.e., 25 years), rather than the period of record. The specific discharges being calculated were the exceedance flows for selected time periods (e.g., weeks or months), rather than flows for individual days.

$$Q_{EFSFSR\ i\%_{25\text{-years}}} = Q_{EFSFSR\ i\%_{por-13311250}} \frac{Q_{Johnson\ i\%_{25\text{-years}}}}{Q_{Johnson\ i\%_{por-13311250}}}$$

Where:

25-years = period of record to estimate fish passage design flows (1993–2017)

i% = desired exceedance percentage (5 or 95)

por-13311250 = period of record for EFSFSR gage 13311250 (2011–2017)

Q_{EFSFSR} = discharge for the EFSFSR at USGS 13311250

$Q_{Johnson}$ = discharge for the EFSFSR at USGS 13311250

The 5% and 95% exceedance flows can be calculated based on flows over the entire year, or for flows from other, shorter time periods (e.g., the month of January). Key migration periods were calculated for Chinook salmon and bull trout, steelhead, and juvenile migrant fish (Table 1).

Table 1. Key migration periods and 5 and 95 percent exceedance flows for spring/summer Chinook salmon, bull trout, steelhead, and juvenile migrants (Barrett and Miller 2018).

Species and Life Stage	Time Period	Percent Exceedance Flows	
		5 th	95 th
Chinook Salmon (adult)	Jul 8–Sep 30	54	8.1
Bull Trout (adult)			
Steelhead (adult)	Ap 1–May 31	237	8.8
Juvenile Salmonids	Year-round	139	8.2

References

- Barrett, J and M. Miller. 2018. Analysis of stream flows and fish passage in the EFSFSR, and implications for the design of fishway in the proposed EFSFSR diversion tunnel. Memo to Midas Gold Idaho, Inc. Boise, ID. Memo dated 15 May 2018
- NMFS (National Marine Fisheries Service). 2011. Anadromous Salmonid Passage Facility Design. July 2011
- Rio ASE (Rio Applied Science and Engineering). 2019. Stream design report, Stibnite Gold Project. Prepared for Midas Gold, Boise, Idaho. Prepared by Rio ASE, Boise, Idaho. February.

Appendix B: Sediment Transport

Memorandum

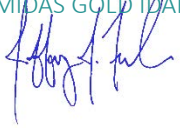

Rio ASE 2601 W. Woodlawn Ave., Boise, Idaho 83702, Telephone: 208-866-8753

TO: GENE BOSLEY – MIDAS GOLD IDAHO, INC.
FROM: JEFF FEALKO 
DATE: JUNE 28, 2019
FILE: 023-090-001-04
SUBJECT: SEDIMENT TRANSPORT ON EFSFSR

This memo summarizes the development of average annual sediment transport rate estimates for bedload and suspended sediment for the East Fork South Fork Salmon River (EFSFSR) at the proposed EFSFSR Tunnel south (upstream) portal for the proposed Stibnite Gold Project. The EFSFSR Tunnel would be activated concurrently with the repair of the Blowout Creek gully (a major fine sediment source in the watershed) and would bypass the present Yellow Pine pit lake, a known sediment trap. Therefore, the results described herein will vary from previous studies in the EFSFSR watershed (Etheridge 2015) that assessed suspended load, but will provide a more realistic estimate of average bedload sediment transport rates, potentially useful in assessing cleanout intervals, equipment and manpower needs, and sizing for the sediment trapping features of the EFSFSR Tunnel headworks. Rio ASE obtained sediment transport data from a larger study (King et al. 2004; 31 total sites) and utilized data from four streams nearest the project site and located within the South Fork Salmon basin watershed to estimate average annual sediment transport rates within the EFSFSR. These streams included Blackmare Creek, Dollar Creek, South Fork Salmon River, and the West Fork of Buckhorn Creek (Rio ASE omitted one data point near the Stibnite Gold Project site and within the South Fork Salmon River watershed, Johnson Creek, as using Johnson Creek data would have significantly lowered the estimated sediment transport rate reducing some conservatism within the estimates).

King et al. (2004) measured bedload with a pressure-difference Helley-Smith bedload sampler, typically with a 3-inch square entrance, but occasionally a 6-inch square entrance during higher flows. The catch bag had a 0.25-millimeter mesh, and they assumed a trapping efficiency of 100% for all particle sizes. All material (bedload or suspended) captured in the bedload sampler was assumed to be bedload (King et al. 2004). Suspended sediment samples were collected using either a wading or suspension version of a depth integrating sampler and was sampled approximately 10 times through a cross section to obtain a mean rate of transport through the section (King et al. 2004).

Using the King et al. (2004) data for the four sites identified above, Rio ASE developed two regression equations (one for bedload and one for suspended load) to relate basin area to a daily sediment transport rate associated with the bankfull discharge. Figure 1 below shows the regression equation utilized for bedload transport rate, while Figure 2 shows the regression equation utilized for suspended sediment transport rate. These two figures show the four sites used in the development of the regression equations (red circles) along with the other locations (only basins less than 500 square miles are shown for visual clarity) from the King et al. (2004) study. The regression equations

shown within these figures estimate the sediment transport rate (bedload or suspended load) associated with the bankfull discharge based on the basin area.

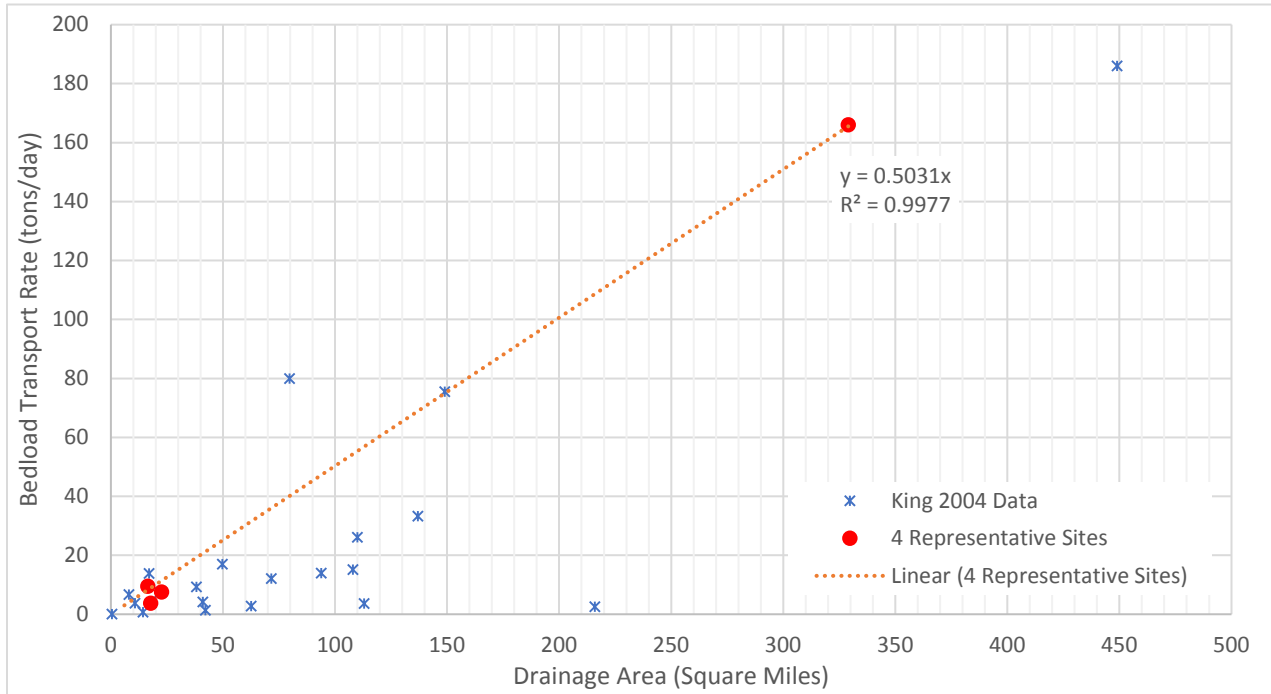

Figure 1. Bedload sediment transport rate at bankfull discharge versus the drainage area of study sites (King et al. 2004).

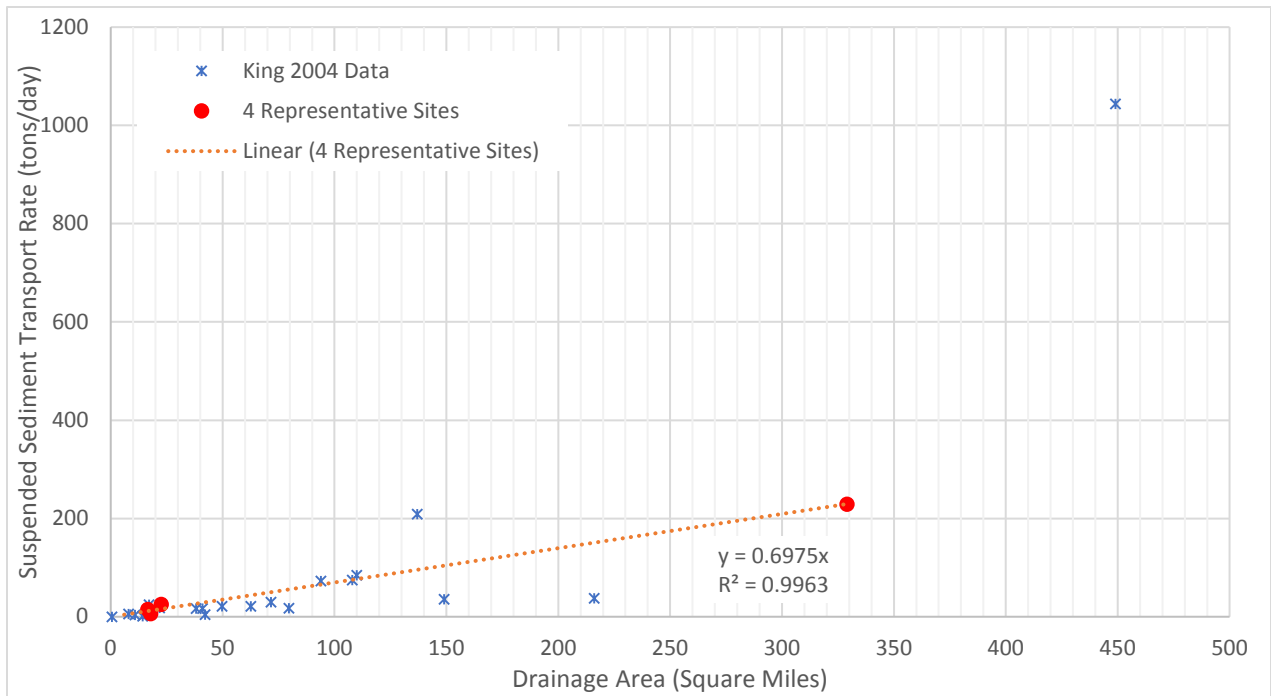

Figure 2. Suspended sediment transport rate at bankfull discharge versus the drainage area of study sites (King et al. 2004).

Equations 1 and 2 are regression equations to estimate sediment transport rates associated with the bankfull discharge for bedload and suspended sediment, respectively. These equations estimate transport rates in tons per day. Based on the King et al. (2004) report, the South Fork Salmon River is at or above bankfull discharge approximately 4% of the year (15 days/year) and transports 72.6% of its annual bedload sediment at flows equal to or above bankfull discharge. This one site was used rather than an average of the four proximity sites, as it was the only site with gage information to develop the estimate of discharge exceedance and allow conversion from a bankfull sediment transport rate to an average annual transport rate. Knowing that the sediment discharge rate increases at flows above the bankfull discharge, we looked at how depth is utilized within the Meyer-Peter and Muller, and Parker sediment transport equations. Sediment transport is proportional to the depth raised to a power of 1.5 as seen in Equation 3 (Barry, 2007). From this Rio assessed the average daily annual hydrograph and compared that to a stage discharge relationship developed from the nearest USGS gage (USGS Gage 13311250) to estimate the increased sediment transport at flows greater than the bankfull discharge for an average year. The daily sediment transport rates for days with discharges equal to or greater than bankfull discharge were calculated and summed as seen on Figure 3.

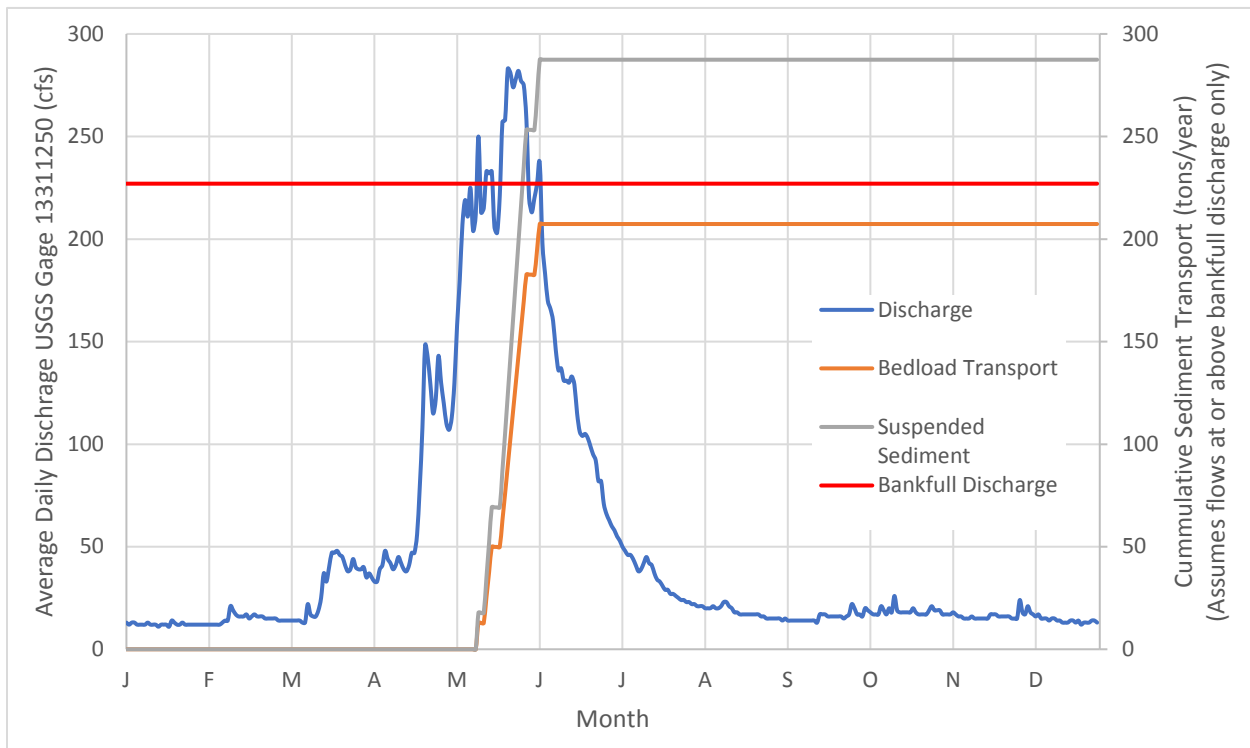

Figure 3. Annual hydrograph for USGS Gage 13311250 and estimated cumulative bedload and suspended sediment transport rate at flows equal to or greater than bankfull.

The respective sums are 207 tons/year of bedload and 287 tons/year of suspended sediment. Based on the research from the King study bankfull or greater flows represent 72.6 percent of the average annual sediment load. With this information, estimated annual sediment transport rates can be scaled to arrive at an approximation of the average annual sediment transport. The resulting equations, combining the bankfull transport-drainage area regression with scaling factors, are provided as Equations 4 and 5 for bedload and suspended sediment, respectively.

$$Q_{BF-Bed} = 0.5031 * DA \quad (1)$$

$$Q_{BF-Sus} = 0.6975 * DA \quad (2)$$

$$Q_{Sediment} \propto C * D^{1.5} \quad (3)$$

$$Q_{Bedload} = \frac{\sum Q_{\geq BF-Bed} \left(\frac{tons}{year} \right)}{72.6\%} \quad (4)$$

$$Q_{Suspended} = \frac{\sum Q_{\geq BF-Sus} \left(\frac{tons}{year} \right)}{72.6\%} \quad (5)$$

Where:

72.6% = approximate percentage of annual sediment load that is transported by flows at or above the bankfull discharge

DA = drainage area (square miles) (22.76 square miles at the EFSFSR Tunnel south portal)

C = Coefficient

D = Flow depth (ft)

$Q_{sediment}$ = Sediment transport rate (tons/day)

Q_{BF-Bed} = average bankfull bedload transport rate (tons/day)

Q_{BF-Sus} = average bankfull suspended sediment transport rate (tons/day)

$Q_{Bedload}$ = average bedload transport rate (tons/year)

$Q_{\geq BF-Bed}$ = Annual bedload transport rate from flows greater than or equal to bankfull (tons/year)

$Q_{\geq BF-Sus}$ = Annual bedload transport rate from flows greater than or equal to bankfull (tons/year)

$Q_{Suspended}$ = average suspended sediment transport rate (tons/year)

Utilizing the equations above, it is estimated that, in an average year, approximately 286 tons of bedload and 396 tons of suspended load will be transported to the proposed tunnel entrance location on the EFSFSR.

References

- Barry, J.J. 2007. Bed load transport in gravel-bed rivers. University of Idaho. 118p.
- Etheridge, A.B. 2015. Occurrence and transport of selected constituents in streams near the Stibnite mining area, central Idaho, 2012–14: U.S. Geological Survey Scientific Investigations Report 2015–5166. 47p.
- King, J.G., W.W. Emmett, P.J. Whiting, R.P. Kenworthy, and J.J. Barry. 2004. Sediment transport data and related information for selected coarse-bed streams and rivers in Idaho. Gen. Tech. Rep. RMRS-GTR-131. For Collins, CO: U.S. Department of Agriculture, Forest Service, Rocky Mountain Research Station. 26 p.