

Prepared for  
Midas Gold Idaho, Inc., Valley County, Idaho



FINAL

# Stibnite Gold Project Water Quality Management Plan

March 2020

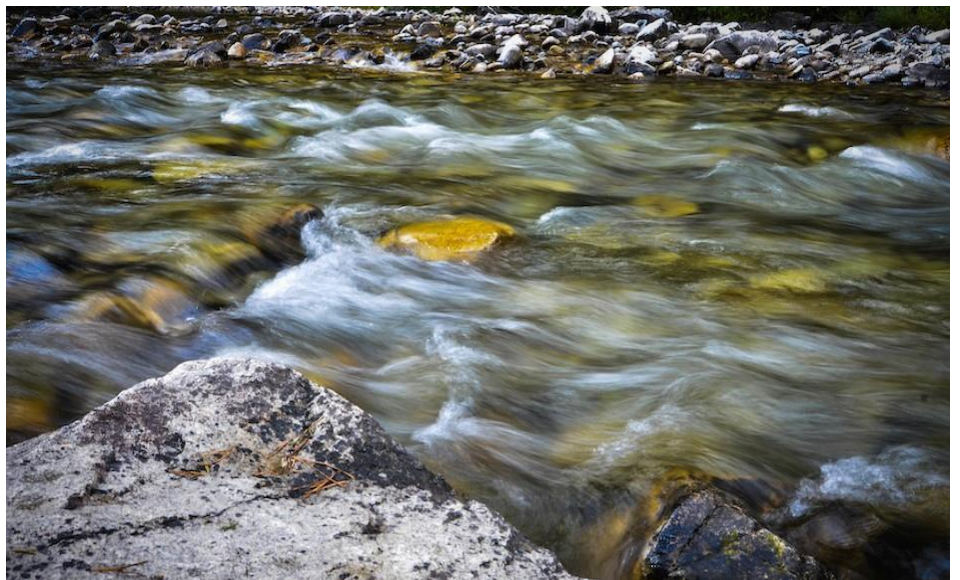

FINAL

## Stibnite Gold Project Water Quality Management Plan

---

Prepared for  
Midas Gold Idaho, Inc.  
Valley County, Idaho  
March 27, 2020

Project Number 154537



950 West Bannock Street, Suite 350  
Boise, ID 83702

# Table of Contents

List of Figures .....	iii
List of Tables .....	iv
List of Abbreviations .....	vi
Executive Summary .....	1
1. Introduction .....	1-1
1.1 Purpose and Organization of Report .....	1-1
1.1.1 Plan Purpose.....	1-1
1.1.2 Report Organization .....	1-2
1.2 Background Information.....	1-2
2. Water Management Approach .....	2-1
2.1 Water Management Objectives .....	2-1
2.2 Project Water Components .....	2-2
2.2.1 Non-Contact Water .....	2-2
2.2.2 Mine-Impacted Water.....	2-3
2.3 Water Management Overview.....	2-5
2.3.1 Water Management – Construction.....	2-5
2.3.2 Water Management – Operations.....	2-7
2.3.3 Water Management – Reclamation, Closure, and Post-Closure .....	2-10
2.4 Treatment Premise .....	2-15
2.5 Ambient Surface Water Quality.....	2-16
2.6 Adaptive Management .....	2-18
3. Treatment System Flow Capacity .....	3-1
3.1 Mine Construction and Operation Flows Summary .....	3-1
3.2 Reclamation and Post-Closure Flows Summary .....	3-9
3.2.1 TSF Supernatant Pond Water .....	3-9
3.2.2 TSF Post-Closure Consolidation Waters.....	3-9
3.2.3 Post-Closure RIBs Operation with Yellow Pine Pit Dewatering Water .....	3-11
3.2.4 Post-Closure Fiddle DRSF Toe Seepage .....	3-11
3.2.5 Post-Closure Hangar Flats and West End Pit Lake Water.....	3-11
4. Treatment System Influent Water Quality.....	4-1
4.1 Mine Construction and Operations Water Quality Summary .....	4-1
4.2 Mine Reclamation and Post-Closure Water Quality Summary.....	4-3
4.2.1 Reclamation and Post-Closure Flows to WTP – Water Quality Design Basis.....	4-3
4.2.2 TSF Consolidation Waters Passive Treatment System – Water Quality Design Basis.....	4-7

4.2.3	Fiddle DRSF Toe Seepage Passive Treatment System – Water Quality Design Basis.....	4-8
4.2.4	West End Pit Lake Overflow Water – Water Quality Design Basis .....	4-9
5.	Treatment Objectives.....	5-1
6.	Identification and Screening of Treatment Technologies.....	6-1
6.1	Evaporation .....	6-1
6.2	Iron Coprecipitation .....	6-1
6.3	Sulfide Precipitation .....	6-2
6.4	Adsorption .....	6-3
6.5	Ion Exchange.....	6-3
6.6	Membrane Treatment .....	6-4
6.7	Biochemical Reactor/Wetlands.....	6-4
6.8	Screening Summary .....	6-5
7.	Treatment During Construction and Operations .....	7-1
7.1	Process Description.....	7-1
7.2	Equipment.....	7-4
7.3	Chemicals Needed.....	7-4
7.4	Treatment Selection Considerations .....	7-5
7.5	Temporary Treatment Systems Operating During Construction and Early Operations .....	7-6
7.6	Sanitary Wastewater Treatment .....	7-8
7.7	Evaluation of Stream Temperature Effects Resulting from Treated Water Discharge.....	7-8
7.7.1	Approach.....	7-8
7.7.2	Results .....	7-10
7.8	Comparison of Monthly Average EFSFSR Flows and Temperatures with Treated Water Discharge .....	7-11
7.9	Comparison of Simulated Maximum and Average Temperatures for the Maximum Weekly Summer Condition.....	7-15
7.10	Potential Temperature Mitigation Measures .....	7-19
8.	Treatment During Reclamation and Post-Closure.....	8-1
8.1	Treatment at the WTP During Reclamation and Post-Closure.....	8-1
8.1.1	Process Description .....	8-2
8.1.2	Equipment.....	8-5
8.1.3	Chemicals Needed .....	8-5
8.2	Treatment of TSF Consolidation Water and Runoff Post-Closure.....	8-5
8.3	Treatment of Fiddle DRSF Toe Seepage Post-Closure .....	8-6
8.4	Contingent Plan for West End Pit Lake Water Treatment .....	8-7
9.	Scalability.....	9-1
10.	Projected Surface Water Quality .....	10-1
11.	Schedule.....	11-1
12.	Conclusions .....	12-1

13. References .....	13-1
Appendix A: SRK Consulting Stibnite Water Treatment Evaluation .....	A-1
Appendix B: Temperature Tables .....	B-1

## List of Figures

Figure 2-1. Surface Water Management Features .....	2-11
Figure 2-2. Flow Diagram for Construction Mine Year -1 .....	2-12
Figure 2-3. Flow Diagram for Operations Typical Mine Year .....	2-13
Figure 2-4. Flow Diagram for Post-Closure Mine Years 18-21.....	2-14
Figure 2-5. Adaptive Management Process .....	2-19
Figure 7-1. Proposed Water Treatment Facilities .....	7-2
Figure 7-2. Process Flow Diagram of WTP During Operations .....	7-3
Figure 7-3. Process Flow Diagram of Membrane System .....	7-7
Figure 7-4. Distribution of Monthly Air Temperatures (boxes are 25th, 50th, and 75th percentile values for the daily average temperatures).....	7-11
Figure 7-5. Estimated Stream Flows in EFSFSR below Meadow Creek Resulting from Treated Water Discharge Compared to USGS Observations at Gage 13311000 .....	7-13
Figure 7-6. Estimated Stream Temperatures in EFSFSR below Meadow Creek Resulting from Treated Water Discharge Compared to USGS Observations at Gage 13311000 .....	7-14
Figure 7-7. Average Discharge Flow Rate to the RIBs and Surface Water for July/August by Mine Year for Average Water Yield Scenario .....	7-16
Figure 7-8. Average WTP Effluent Temperature for July/August by Mine Year for Average Water Yield Scenario .....	7-16
Figure 7-9. Simulated Average Temperatures for the Treated Water Discharge Scenarios Under the Maximum Weekly Summer Condition using the SPLNT Model .....	7-18
Figure 7-10. Simulated Maximum Temperatures for the Treated Water Discharge Scenarios Under the Maximum Weekly Summer Condition using the SPLNT Model.....	7-18
Figure 8-1. Process Flow Diagram of WTP During Reclamation and Post-Closure with Residuals Pumped to the TSF .....	8-3
Figure 8-2. Process Flow Diagram of WTP During Reclamation and Post-Closure with Residuals Dewatering and Off-site Landfill Disposal.....	8-4
Figure 9-1. Water Treatment Development Flow Chart.....	9-2

## List of Tables

Table 2-1. Design Criteria for Contact Water Storage Ponds .....	2-9
Table 2-2. Proposed Water Treatment Schedule (assuming 12-year mine operations period <sup>a</sup> ) .....	2-17
Table 3-1. Maximum Month Contact Water Flow Rates by Source during Mine Construction .....	3-2
Table 3-2. Projected Maximum Month Contact Water Flow Rates by Source During Operations (assuming a 12- year mine operations period) .....	3-3
Table 3-3. Average Annual Groundwater Dewatering Flow Rates by Source During Mine Operations (assuming a 12-year mine operations period) .....	3-4
Table 3-4. Annual Projected Volumes of Contact Water and Groundwater Dewatering Water for the Average Year Condition .....	3-5
Table 3-5. Projected Combined Available Storage in the Contact Water Ponds (assuming a 12-year mine operations period).....	3-6
Table 3-6. Flows for Water Treatment and/or Evaporation Following Flow Equalization Contact Water Ponds Partial Diversion to TSF and in Pit Storage.....	3-7
Table 3-7. Water Balance Summary for the Average Year Condition .....	3-8
Table 3-8. Annual Average TSF Flows to the Active WTP During Post-Closure (assuming 12 years of mine- operations period).....	3-10
Table 3-9. Monthly TSF Runoff and Cover Seepage Flows.....	3-10
Table 4-1. Predicted Average Dissolved Concentrations for the Comingled Contact Waters.....	4-2
Table 4-2. Anticipated Water Sources to be Treated at the WTP During Reclamation and Post-Closure .....	4-4
Table 4-3. Predicted Average Dissolved Concentrations to the WTP During Reclamation and Post- Closure .....	4-5
Table 4-4. Predicted Average Dissolved Concentrations for the TSF Consolidation Water Mixture...	4-7
Table 4-5. Predicted Average Dissolved Concentrations from the Fiddle DRSF Toe Seepage During Reclamation and Post-Closure .....	4-8
Table 4-6. Predicted Average Dissolved Concentrations of the West End Pit Lake .....	4-10
Table 5-1. Applicable Water Quality Criteria.....	5-1
Table 5-2. WTP Treatment Objectives .....	5-3
Table 6-1. Screening Summary for WTP Technology .....	6-5
Table 7-1. WTP Major Equipment List .....	7-4
Table 7-2. WTP Chemical List During Mine Operations.....	7-4
Table 7-3. Anticipated Constituent Removal by WTP .....	7-5
Table 7-4. Monitoring Stations Used to Develop Contact Water Runoff Temperatures.....	7-9
Table 7-5. Monthly Average Temperatures Applied to Contact Water Runoff Temperature.....	7-9

Table 7-6. SPLNT Model Inputs for the Evaluation of Three Mine Years for the Plan, Average Water Yield Scenario, Maximum Weekly Summer Condition ..... 7-17

Table 8-1. Additional Major WTP Equipment Needed for Residuals Dewatering and Disposal..... 8-5

Table 8-2. WTP Chemical List During Reclamation ..... 8-5

Table 11-1. Proposed Water Treatment Schedule (assuming a 12-year mine operations period) and Treatment System Types..... 11-2

Table 11-2. Post-Closure Water Treatment Schedule (assuming a 12-year mine operations period)..... 11-3



## List of Abbreviations

---

°C	degree Celsius
ac-ft	acre feet
As	arsenic
Avg	average
BC	Brown and Caldwell
BCR	biochemical reactor
BMP	best management practice
CaCO <sub>3</sub>	calcium carbonate
CFR	Code of Federal Regulations
cfs	cubic feet per second
CCC	criterion continuous concentration
CMC	criterion maximum concentration
cms	cubic meter per second
District	Stibnite Mining District
DRSF	development rock storage facility
EFSFSR	East Fork of the South Fork of the Salmon River
EIS	Environmental Impact Statement
ELG	Effluent Limitation Guideline
EOY	end of year
EPA	United States Environmental Protection Agency
ft	foot/feet
gal/year	gallon per year
GLM	General Lake Model
gpm	gallon per minute
HDR	HDR Engineering, Inc.
IDAPA	Idaho Administrative Procedures Act
IDEQ	Idaho Department of Environmental Quality
IPDES	Idaho Pollutant Discharge Elimination System
lb/yr	pound per year
MG	million gallon
mg/L	milligram per liter
Midas Gold	Midas Gold Idaho, Inc.
ModPRO	Modified Plan of Restoration and Operations
MSGP	Multi-Sector General Permit
N	nitrogen
N/A	not applicable
NEPA	National Environmental Policy Act
NF	nanofiltration

ng/L	nanogram per liter
PCTL	percentile
Plan	Water Quality Management Plan
PRO	Plan of Restoration and Operations
RIB	rapid infiltration basin
RO	reverse osmosis
Sb	antimony
SGP	Stibnite Gold Project
SODA	spent ore disposal area
SPLNT	stream and pit lake network temperature
SRK	SRK Consulting, Inc.
s.u.	standard unit (pH)
SWWB	site-wide water balance
SWWC	site-wide water chemistry
SWPPP	Stormwater Pollution Prevention Plan
TCLP	toxicity characteristic leaching procedure
TSF	tailings storage facility
USGS	United States Geological Survey
VF	vertical flow
WOTUS	Waters of the United States
WTP	water treatment plant
WWTP	wastewater treatment plant

# Executive Summary

From the outset of the Stibnite Gold Project (SGP), Midas Gold Idaho, Inc. (Midas Gold), has set an objective of improving the currently impaired water quality for the Stibnite Mining District (District). Since 2012, Midas Gold has taken the following actions to meet this objective:

- Conducted water quality sampling to define existing baseline conditions, which are impaired according to the Idaho 2016 Integrated Report
- Reviewed the results of this water quality sampling to conduct preliminary evaluations of sources of impairment, to the extent possible:
  - The natural environment (related to widespread, naturally occurring mineralization that included arsenic, antimony, and mercury)
  - Anthropogenic sources, primarily related to historical mining activity
- Evaluated the potential impacts of the proposed redevelopment of the District on water quality, and incorporated mitigations to those impacts, such as:
  - Removing legacy impacts (e.g., tailings and waste rock)
  - Diverting clean stormwater around the proposed mine facilities to keep non-impacted water clean
  - Reducing the SGP footprint by eliminating the West End development rock storage facility (DRSF) and partially backfilling the Hangar Flats pit to decrease the potential impacts
  - Installing low-permeability caps on the Fiddle DRSF and the top of Hangar Flats DRSF at closure
  - Incorporating additional mitigations to reduce water quality impacts
- Developed this Draft Water Quality Management Plan (Plan) to improve water quality where required

This Plan represents the culmination of these efforts but is not the end of the process. Midas Gold continues to evaluate opportunities to meet its goal of improving water quality based on the results of water quality modeling completed to date and, as part of this continued effort, will take into account comments on this draft Plan from federal and state agencies, and those received during the comment period on the Draft Environmental Impact Statement (EIS).

Key objectives to be further evaluated include the following:

- Reducing volumes of water required to be actively treated through a refined project footprint, enhanced evaporation, and improved separation of non-mine-impacted water from the Project site
- Improving water quality from the legacy impact areas that are not part of the currently proposed activities related to the SGP
- Refining project models based on consultation with federal and state agencies, and using best professional judgement
- Determining water quality permit limits for specific outfalls via the Idaho Pollutant Discharge Elimination System (IPDES) process

These efforts will continue in parallel with the National Environmental Policy Act (NEPA) process and potential further improvements to water quality for the District will be incorporated into a final Water Management Plan to be completed between the Draft EIS and the Final EIS.

This Plan was prepared for Midas Gold SGP by Brown and Caldwell as part of Midas Gold's overall water management program, which will continue to be refined and adapted throughout the permitting process and during the mine life, as is typical with complex mining and industrial projects. When considered in the context of overall water management, this Plan describes the treatment to be provided for mine-impacted water prior to its discharge to Waters of the United States, in compliance with the IPDES permit being sought by Midas Gold. This Plan addresses how treatment will be implemented and adapted over the mine life from construction through post-closure. It addresses treatment of mine-impacted water from the various sources at the SGP mine. Although specifics of the Plan are generally aligned with the Modified Plan of Restoration and Operations (ModPRO - Alternative 2 in the NEPA review process), this Plan can be adapted to all alternatives being evaluated for the Draft EIS. Treatment of the Hangar Flats pit lake water in Alternatives 1, 3, and 4 will require a treatment plant with larger flow capacity. For all other components of Alternatives 1, 3 and 4, some changes to the sources, timing, and flow to the water treatment plant (WTP) would be required, but the basic treatment processes selected and described herein are robust enough to accommodate these differences within the same overall Plan.

During construction and prior to the commencement of mine operations, stormwater runoff will be managed under the Multi-Sector General Permit (MSGP) for Stormwater Associated with Industrial Activities using conventional stormwater control measures and best management practices. Midas Gold has addressed stormwater under the MSGP during its exploration activities since 2013. Contact water runoff occurring during the SGP construction phase from disturbed legacy materials and open mine pits in preparatory phase (Yellow Pine pit, West End pit) will be treated using temporary, modular water treatment systems.

During operations, a portion of mine-impacted water (comprising varying proportions of contact stormwater runoff, mine drainage, and process water) is expected to exceed the quantity (or quality) needed for ore processing and other mine uses. Through the use of contact water ponds for equalization, enhanced evaporation, minimization of disturbance areas, clean water diversions, and other water management strategies, Midas Gold will manage such water to minimize the volume that must be treated and discharged. For mine operations, a central WTP will be constructed and operated to remove arsenic, antimony, and mercury from the water to the limits established in the IPDES permit. The treatment system will also remove other constituents of concern that may be included in the IPDES permit.

Contact stormwater runoff from some portions of the Project site during operations (e.g., haul roads outside of pits and DRSFs and not constructed with development rock or legacy materials and staging and storage areas of clean materials) will continue to be managed under the MSGP with conventional stormwater control measures as necessary to meet the conditions of the general permit.

In the WTP, iron coprecipitation will remove arsenic, antimony, and mercury. If confirmation testing indicates this process cannot achieve the mercury treatment objective, the WTP will also include mercury removal by chemical precipitation using an organic sulfide precipitant. During operations, residuals from the WTP will be pumped to the tailings pumping system at the mill, where they will be blended with tailings and sent to the tailings storage facility (TSF). Enhanced evaporation, while rejected for stand-alone treatment, will be used to the extent feasible throughout construction, operations, reclamation, and post-closure to reduce the volume of water requiring treatment.

During the operations period, the mine process water circuit, including the TSF, will be a net consumer of water and is not anticipated to discharge. During closure and reclamation, the WTP will be used to treat TSF supernatant pond water and, initially, TSF runoff water (a mixture of consolidation water, TSF cover seepage, and TSF surface runoff). WTP residuals may continue to be transferred to the TSF during early reclamation or may be thickened, dewatered, and transported off site to a landfill. The type of landfill depends on the characteristics of the residuals, which will be determined by testing. The residuals are not expected to be classified as hazardous waste.

Non-process wastewater (sanitary wastewater from worker housing and support facilities) will be managed and treated separately, using a membrane bioreactor (similar to that currently on site and permitted) or similar package system, and discharged in compliance with permit limits established for that system. Non-contact stormwater runoff will be routed around mine facilities to prevent it from becoming mine-impacted water.

After mine closure, Midas Gold will continue to provide treatment of water at the WTP to comply with water quality permit limits. As mine-impacted water volume decreases and water quality improves after closure, treatment of some sources is expected to transition from active to passive biological treatment technologies, in compliance with IPDES permit conditions. Temporary modular treatment systems may also be implemented, as determined by continued monitoring.

The projected effects of this water quality management program are reflected in updated Site-Wide Water Chemistry modeling results provided by SRK Consulting Inc., (SRK), (Appendix A). Prior modeling by SRK did not fully consider the water management and treatment measures discussed in this Plan. The updated results show substantially improved water quality in the receiving waters, relative to those presented in the ModPRO modeling report (Brown and Caldwell 2019b).

It is important to note that ambient surface water quality in some stream reaches at the Project site includes concentrations of some constituents—particularly arsenic, antimony, and mercury—at levels above Idaho surface water criteria. This Plan is designed to address the quality of water sources that may be impacted by Midas Gold’s activities at the Project site. In addition, certain proposed actions by Midas Gold are expected to reduce or remove legacy sources of contamination, which will also improve water quality at the Project site. However, while overall water quality for the site should be improved as compared to current conditions, it may not be possible to reduce overall concentrations in the surface waters throughout the district to concentrations below applicable Idaho water quality criteria because: (1) the quantity of water expected to be managed and treated is a small proportion of the overall surface water discharge from the Project site, and (2) the naturally<sup>1</sup> mineralized conditions present at the Project site and surrounding area.

---

<sup>1</sup> Idaho defines “natural background conditions” as “The physical, chemical, biological, or radiological conditions existing in a water body without human sources of pollution within the watershed.” (Idaho Administrative Procedures Act [IDAPA] 010.63). They use the term in the narrative criteria in IDAPA 200.09 as “When natural background conditions exceed any applicable water quality criteria set forth in Sections 210, 250, 251, 252, or 253, the applicable water quality criteria shall not apply; instead, there shall be no lowering of water quality from natural background conditions.” Natural background conditions could be used by Idaho Department of Environmental Quality to set site-specific alternative criteria (IDAPA 275.01), which can take time. The WQMP does not contain an assessment of natural background conditions, as that evaluation is preliminary.

## Section 1

# Introduction

This Water Quality Management Plan (Plan) was developed for the Midas Gold Idaho, Inc. (Midas Gold) Stibnite Gold Project (SGP) by Brown and Caldwell (BC). It is part of Midas Gold's overall water management program, which will continue to be refined and adapted throughout the National Environmental Policy Act (NEPA) analysis, permitting process, and during the mine life, as with all complex mining and industrial projects. Water management will be generally aligned with the SGP Water Management Narrative (BC 2018c) developed previously. This Plan describes the treatment to be provided for mine-impacted water prior to its discharge to Waters of the United States (WOTUS), in compliance with the Idaho Pollutant Discharge Elimination System (IPDES) permit being sought by Midas Gold. It addresses how treatment will be implemented and adapted over the mine life from construction through post-closure. Specifics of the Plan are generally aligned with the Modified Plan of Restoration and Operations (ModPRO - Alternative 2 in the Environmental Impact Statement [EIS]) being prepared under the NEPA review process, which was selected because it is an improvement on Alternative 1, is Midas Gold's preferred alternative, and the alternative for which we have the most information regarding water management, water quality, and water treatment; however, this Plan can be adapted to all alternatives being evaluated for the EIS. Treatment of the Hangar Flats pit lake water in Alternatives 1, 3, and 4 will require a water treatment plant (WTP) with larger flow capacity. For all other components of Alternatives 1, 3, and 4, some differences in the sources, timing, and flow to the WTP may exist among alternatives, but the basic treatment processes selected are robust enough to accommodate these differences, within the same overall Plan.

The projected effects of this water quality management program are reflected in updated modeling results provided by SRK Consulting, Inc. (SRK), as presented in Appendix A. Prior modeling by SRK did not consider the water management and treatment measures discussed in this Plan. The updated results show substantially improved water quality in the receiving waters, relative to those presented in the ModPRO modeling report (BC 2019b). Opportunities for further improvements will continue to be evaluated during the ongoing permitting process.

## 1.1 -Purpose and Organization of Report

This Plan describes the projected composition and quantity of mine-impacted water and how this water will be managed and treated. Multiple technologies for water treatment were screened to determine which are most suitable for SGP water treatment needs during construction, operations, reclamation, and post-closure.

### 1.1.1 Plan Purpose

The purpose of this Plan is to forecast the amount of water requiring treatment and the concentrations of constituents of concern, as well as establish the design basis for the water treatment systems required to meet applicable permit limits for discharge to surface waters. It is generally intended to provide the NEPA reviewing agencies with the information necessary to evaluate the water quality management program proposed by Midas Gold in the development of an EIS. Again, we note that for the purpose of preparing this Plan, the ModPRO was considered as the base case scenario, and the design basis deriving from it was used to inform the sizing and sequencing of the engineering elements presented herein. Once a preferred alternative is selected, it

is fully anticipated that this Plan will be updated and revised to account for variances in the location and size of various facilities, and accordant modifications that must occur to adequately manage and treat waters associated with that alternative. However, the basic treatment concepts provided here will remain unchanged.

### **1.1.2 Report Organization**

Section 1 outlines the Plan purpose and organization and references relevant background information.

Section 2 describes the overall water management approach for the SGP, including water type definitions, water sources to be treated, and the premise for the treatment system.

Section 3 describes the anticipated treatment system capacity, which is based on projected flow rates from individual sources.

Section 4 describes the treatment system influent water quality, calculated from a weighted average composition of the individual sources.

Section 5 discusses the treatment objectives.

Section 6 discusses the process for identifying and screening the treatment technologies.

Section 7 describes the WTP proposed for use during construction and mine operations.

Section 8 describes water treatment proposed during reclamation and post-closure.

Section 9 presents a schedule for the water treatment program.

Section 10 provides conclusions from information presented in this Plan.

Section 11 lists references cited herein.

## **1.2 Background Information**

Much of the relevant background on the SGP is described in other SGP documents previously submitted by Midas Gold, including the Plan of Restoration and Operations (PRO), (Midas Gold 2016), Hydrologic Model Proposed Action Report (BC 2018b), Proposed Action Site Wide Water Chemistry (SWWC) Modeling Report (SRK 2018), SGP EIS ModPRO Chapter 2 Technical Memorandum (BC 2019a), and the ModPRO Alternative Modeling Report (BC 2019b).

## Section 2

# Water Management Approach

This section provides an overview of the overall water management approach for the SGP, as well as the objectives for water management and water treatment through the life of the mine.

## 2.1 Water Management Objectives

Water management for the SGP is driven by the desire to minimize impacts to the existing Project site, address certain legacy impacts, and the need to meet local, state, and federal water quality requirements applicable to mine-impacted water. Water management is particularly critical at the Project site given that the East Fork of the South Fork of the Salmon River (EFSFSR) and various tributaries host threatened and sensitive fish species and are 303(d) listed for one or more constituents, including arsenic, antimony, and mercury. A system of surface water management features, pit dewatering infrastructure, contact water storage, pumping and piping, and water treatment (presented herein) will need to be developed to meet the following overall water management objectives:

- Temporarily divert freshwater streams and non-contact stormwater around mine features as needed during construction, operations, and early reclamation to prevent formation of contact water and to protect water quality and downstream aquatic habitat.
- Remove or otherwise address certain legacy impacts from historical mining activity across the Project site.
- Route surficial groundwater expressions (i.e., seeps and springs) under mine facilities (e.g., the tailings storage facility [TSF] and development rock storage facilities [DRSFs]) in underdrains to prevent contact and limit the amount of water requiring treatment during construction, operations, and post-closure.
- Minimize erosion and sediment generation, promote fish passage, increase spawning and rearing habitat, and rehabilitate previous disturbances.
- Supply an adequate quantity and quality of makeup water to the ore processing facility during commissioning, startup, and operations.
- Dewater aquifers in the vicinity of open pits to achieve safe and efficient working conditions within the pits during operations.
- Manage and treat mine drainage and contact water to ensure compliance with Idaho Pollutant Discharge Elimination System (IPDES) requirements and water quality standards.
- Permanently restore or enhance streams to re-establish stream and riparian habitat to a stable yet dynamic configuration that supports fish passage, spawning, and rearing.
- Restore the Project site to a self-sustaining ecosystem with improved water quality and enhanced habitat for native fish and wildlife populations.

Water management strategies and controls will be developed using the adaptive management approach described in Section 2.6, which will allow for designs and analyses needed to accommodate changes in mining operations or to account for new site-specific information obtained throughout the mine construction, operations, reclamation, and post-closure.

Water management features that will be used to manage water through the life of the mine include the following:

- Stormwater and surface water diversions
- Underdrains to divert groundwater/seeps/springs
- Active tunnel diversion for the EFSFSR during construction and operations
- Source removal of certain materials related to legacy mining impacts
- Contact water ponds and pipelines
- Pit dewatering wells, pipelines, and storage tanks
- TSF
- Tailings and TSF water reclaim pipelines and emergency pond
- Rapid infiltration basins (RIBs) to return water to the alluvial aquifer
- Water treatment systems
- Open mine pits (for high volume water years)

Diversions, underdrains, underdrain outlets, and contact water ponds would utilize low-permeability liners or solid-wall pipes as required to maintain segregation of clean and potentially mine-impacted water, promote geotechnical stability, and/or prevent water loss.

## 2.2 Project Water Components

Water types are categorized based on exposure to mine activity and, if the source is primarily stormwater, to provide a framework for water management requirements at the SGP. There are two general categories in the context of the treatment requirements including non-contact water and mine-impacted water, which are defined in the following subsections.

### 2.2.1 Non-Contact Water

**Non-contact water** refers to water generated from precipitation and not impacted by mining activity. Predicted flows and specific management features for this water type will continue to be refined as mine Planning proceeds and can be adaptively managed based upon monitored conditions during construction and operations. Non-contact water includes the following water types:

- Streams, seeps, and springs: Within the Project site there are natural water sources that will not be impacted by SGP mine activity and are considered non-contact water. Wherever feasible, streams will be diverted around or under the mine features to avoid contact with mine facilities.
- Non-contact stormwater: The regulatory definition of stormwater is “Stormwater runoff, snow melt runoff, and surface runoff and drainage” (40 Code of Federal Regulations [CFR] §122.26(b)(13)). Non-contact stormwater runoff is differentiated from contact stormwater runoff and includes runoff during earth disturbances for construction of the ore processing facility and mine infrastructure, worker housing facility, EFSFSR tunnel, site access roads, and off-site facilities. If ore grade, mineralized, or legacy materials are encountered during construction of the mine features, stormwater runoff from these areas will be contained and managed as contact water. Additionally, upslope stormwater diversions may be installed to divert clean stormwater around the area during construction. Runoff post-construction from new facilities that is not impacted by mine activity is also considered non-contact stormwater water and includes runoff from upslope areas that will be diverted around the mine features. Non-contact stormwater will be diverted around mining facilities in controlled conveyances with erosion and sediment control best management practices (BMPs) as needed.

### 2.2.2 Mine-Impacted Water

The mine-impacted water types that may need treatment during the life of the mine are described below.

**Ore processing water** is used in the ore processing circuit. The ore processing water demand will be met by a combination of reclaimed water from the TSF, contact water, and freshwater makeup (i.e., groundwater from the pit dewatering wells or supply wells). No treatment and discharge of ore processing water is anticipated during mine operations.

**TSF water** is water entrained within or overlying mine tailings. During operations, the stored water in the supernatant pool will be reused in ore processing and supplemented with makeup water as required to meet the ore processing demand. No TSF water will be discharged to surface water during operations. During post-closure and reclamation, the tailings will continue to consolidate, releasing pore water entrained during deposition. Some water will remain permanently entrained with the solids, and some will evaporate. The balance, released during consolidation, is expected to be treated and discharged to surface water during the post-closure period. Midas Gold will strive to minimize the volume of TSF water treated and released to surface waters during reclamation and post-closure. The volume of treated water discharged will not exceed the difference between precipitation on the TSF and any areas contributing to it and evaporation from the same areas on an annual basis.

Both ore processing water and TSF water are process water and will meet the definition of process wastewater (40 CFR 122.2) if they are to be discharged, but as noted above, such discharge is not anticipated during operations, and only a portion of the TSF water is expected to require treatment and discharge during reclamation and post-closure.

**Contact water** consists of stormwater and non-stormwater runoff from proposed mine facilities as described below:

- **Contact stormwater runoff:** Stormwater runoff that has contacted mining features and includes runoff from the DRSFs, ore stockpiles, haul roads, and the Plant site. All contact stormwater will be collected in lined water storage ponds, with the exception of contact stormwater runoff eligible for coverage under the Multi-Sector General Permit (MSGP) such as haul road runoff, which will be managed with BMPs in compliance with Midas Gold's Storm Water Pollution Prevention Plan (SWPPP). Some contact stormwater will be used at the ore processing facility and for dust suppression on the DRSFs and in-pit haul roads (only non-contact water would be used for dust suppression on surfaces outside of pits and DRSFs). The remainder will be treated at the WTP and discharged. The quantity of this water will have a strong seasonal component, with quantities during snowmelt in late spring generally exceeding those of the remainder of the year by an order of magnitude or more. During the winter months, there will likely be little or none of this water requiring treatment and discharge. Lined water storage ponds will be employed to partially equalize the water treatment capacity for this source.
- **Mine drainage:** A type of contact water defined by federal regulations as any water drained, pumped, or siphoned from a mine (40 CFR §440.132(h)). It includes seepage from DRSFs and water that accumulates in the mine pits. Non-contact stormwater or contact stormwater that commingles with mine drainage becomes mine drainage. Mine drainage will be collected in the pits and in lined water storage ponds and either used at the ore processing facility or treated prior to discharge to a surface stream outfall. The term "mine drainage" should not be confused with "acid mine drainage." While mine drainage is a common occurrence at most mines, predictive geochemical modeling has shown that acid mine drainage is not a risk for the SGP mine operations (SRK 2018). This water will also have a seasonal pattern, but likely not as

pronounced as for contact stormwater runoff. Lined water storage ponds may also be used to help equalize this temporal differential.

The following individual contact water sources are considered in this Plan

<sup>2</sup> and include construction, operations, and post-closure sources:

- Hangar Flats pit water
- West End pit water
- Yellow Pine pit water
- Hangar Flats pit dewatering water<sup>3</sup>
- West End pit dewatering water<sup>2</sup>
- Yellow Pine pit dewatering water<sup>2</sup>
- Hangar Flats DRSF runoff and/or TSF embankment runoff
- Fiddle DRSF runoff
- Fiddle DRSF toe seepage
- Groundwater in underdrains that commingles with mine drainage<sup>4</sup>
- Bradley tailings runoff
- Plant area (including ore stockpiles) stormwater runoff
- Hecla heap runoff
- Spent ore disposal area (SODA) runoff
- Haul road runoff from haul roads in pits and DRSFs (road segments not deemed eligible for coverage under the MSGP)
- Haul road runoff from roads outside of pits and DRSFs and not constructed of development rock or legacy materials (runoff eligible for coverage under the MSGP)
- TSF runoff (reclamation and post-closure)
- Hangar Flats pit lake discharge (post-closure)
- Midnight pit lake discharge (post-closure, Alternative 1 only, not described in detail as this Plan is generally aligned with Alternative 2)
- West End pit lake discharge (post-closure)

When available, and if the demand exists, contact water will be used as makeup water for the ore processing facility or other mine needs. Contact water that cannot be used will be disposed either through evaporation, treatment and discharge under the IPDES permit, or managed under the MSGP for Industrial Stormwater Discharges, where applicable. Runoff from the Plant site will be handled as

---

<sup>2</sup> This can be adapted to other alternatives being evaluated for the EIS.

<sup>3</sup> This water is generated from dewatering wells located on the perimeter of the open pits.

<sup>4</sup> Modeling to date (BC 2019b) indicates that groundwater levels during operations and post-closure will be below the base of the Hangar Flats DRSF, and support an expectation that drains installed beneath that facility will remain virtually dry and toe seepage minimal due to the combined effects of complete removal of the SODA and Bradley tailings before DRSF emplacement, TSF liner system, lined surface water diversions, pumping of wells for industrial water supply and pit dewatering during operations, placement of a low-permeability cover on the DRSF and lined stream restoration corridors at closure, and lowered downgradient control on the water table owing to the flatter gradient across the Hangar Flats pit lake. If underdrain flow or toe seepage nonetheless develops, it will be managed appropriately according to its water quality. The water quality impacts of DRSF percolation and TSF liner leakage are assessed in SRK (2018), and any additional management of DRSF water will reduce those predicted impacts.

contact water in the mine water balance, with the priority for use at the ore processing facility because of proximity.

**Pit dewatering water** is groundwater that will be pumped from a network of dewatering wells located at the periphery of each open pit to lower the local water table. Water from these wells will be used as makeup water in the processing circuit to the extent practicable. Dewatering groundwater not used for freshwater makeup will be treated in the WTP and then infiltrated to the alluvial groundwater system through RIBs. Note that the flows to the RIBs will be the same with or without treatment of the dewatering groundwater at the WTP because the dewatered groundwater is not anticipated to be stored prior to being sent to the WTP, and the associated streamflow increase resulting from discharge to RIBs will be unaffected. Dewatering groundwater routed to RIBs will be treated to the same standards as water discharged directly to the stream. Testing will be conducted to determine appropriate discharge/infiltration rates for the RIBs. Midas Gold will seek any required authorization from the Idaho Department of Environmental Quality (IDEQ) to construct and operate the RIBs. Analyses are still under way to refine the volume of dewatering water anticipated to be generated, and that volume depends, at least in part, on the preferred alternative being selected in the Draft EIS. The results of these preliminary analyses suggest that the projected volume of unused water to be treated and disposed may decrease.

**Sanitary wastewater** is conventional domestic wastewater from employee housing and work areas. The sanitary wastewater will be collected and treated in a sanitary wastewater treatment plant (WWTP), as discussed in Section 7.6, and not be included in the feed to the mine WTP. The original source of the water in the sanitary waste stream is potable water to be obtained from groundwater and used by site personnel.

## 2.3 Water Management Overview

The conceptual water management approach is outlined in the following sections for construction (Year -3 to -1), operations (Years 1 to 12+, depending on mine life), and reclamation and closure (Years 13+), followed by the treatment premise and proposed water treatment schedule in Section 2.4. For the basis of this Plan, operations were assumed to last 12 years with reclamation and closure beginning in Year 13; however, should the mine life be extended, reclamation and closure will commence the year following the cessation of operations. Figure 2-1 shows the major surface water management features. Secondary features, such as the haul road diversions, are still in development and will be shown in the Water Management Plan.

### 2.3.1 Water Management – Construction

Infrastructure development and construction is Planned for 2 to 3 years prior to the mill start-up and start of ore processing (Years -3, -2, and -1). Key mine development activities requiring water management during the construction phase include the following:

- Infrastructure development: Non-contact stormwater runoff will be managed during the construction of water management features and infrastructure development (i.e., roadway and mine facilities) through controlled conveyances and erosion and sediment control BMPs as needed.
- Surface water diversions: Surface water diversions will be constructed to divert streams and non-contact stormwater runoff around key mine features (e.g., open pits, TSF, mine facilities, etc.) to minimize contact water generation.

- EFSFSR tunnel: The EFSFSR will be diverted around the Yellow Pine pit in a tunnel. After the fishway tunnel<sup>5</sup> is constructed and operational, the upstream end of the Yellow Pine pit lake will be closed. During construction, Midas Gold will divert the EFSFSR into the tunnel and allow the lake level to passively drop to the elevation of the surface outlet. Upon full diversion into the tunnel, the Yellow Pine pit will be dewatered, following the conditions in Section 8.G.4.2.9 Dewatering Practices of Midas Gold's current MSGP, which is expected to be consistent with the requirements under the Draft 2020 MSGP. The water withdrawn for dewatering in this manner would be from a shoreline or floating intake managed to prevent disturbance of bottom sediments thereby minimizing turbidity in the lake and in the discharged water. The current MSGP and draft 2020 MSGP allow the discharge of uncontaminated, non-turbid water, or discharge of water not meeting these standards via effectively managed and appropriate controls (e.g., settling basin, infiltration). Water within the existing Yellow Pine pit lake and above the current sediment level in the lake will be removed prior to operations and will be pumped downstream without treatment except turbidity controls as needed, as it consists of river water that has not been in contact with mining activities. After the pit lake level is lowered below the outlet elevation, the nearly empty pit will then be used for management of stormwater from pre-stripping operations on the highwalls above the lake. Collected stormwater, groundwater inflows, and remaining river water will be used for construction purposes, transferred to the TSF (when it is lined and available) for future use in ore processing, or treated as contact water to meet applicable water quality standards or permit limits before discharge. Yellow Pine pit lake will remain dewatered until the completion of the Yellow Pine backfill and rerouting of the EFSFSR into the restored stream channel.
- Legacy feature removal: Two legacy features, the Hecla heap and SODA, will be removed, and the material repurposed in the TSF rockfill. Runoff from the areas with repurposed material will be appropriately managed and/or treated and discharged. While there are no known seeps or springs under these features, removing them in advance of DRSF development may reveal seeps that are presently unknown, in which case the seeps would be plumbed into a drain system and managed appropriately at that time—either as contact water if commingled with DRSF seepage (if any), or as non-contact water.
- TSF construction: The engineered rockfill starter embankment will be constructed, along with the diversions, underdrains, and liner system. SODA and Hecla heap material reused for TSF construction will be located above the groundwater level and underdrains, and beneath the TSF basal liner, thereby isolating those materials from interaction with groundwater and infiltrated meteoric water.
- Potable water and sanitary wastewater: Potable water and sanitary wastewater facilities will be developed during construction for use throughout the mine life.

Figure 2-2 shows the water sources and typical water routing for construction in Year -1. Once the TSF liner is in place, the TSF will collect water for the mill start-up through a combination of direct

---

<sup>5</sup> Midas Gold has developed and refined measures for the protection of fish prior to diversion of flows through the tunnel during Endangered Species Act informal consultation meetings with the US Fish and Wildlife Service, NOAA Fisheries, Forest Service, and other state and tribal agencies. Midas Gold developed a draft Fish Salvage and Relocation Plan which was presented to the agencies and refined following agency comments. The Fish Salvage and Relocation Plan will be included in Midas Gold's revised Fisheries and Aquatic Resources Mitigation Plan (FMP), which is part of the Project as proposed. Fish salvage is focused on avoiding the stranding or loss of fish during declining flows, and safe handling during capture and relocation. Once the EFSFSR tunnel, transition channels, and flow control structure are completed and ready for diversion, Midas Gold will gradually divert a portion of the EFSFSR flow into the tunnel, leaving a low flow in the river to prevent stranding fish, then salvage fish from the EFSFSR and the Yellow Pine pit lake. When fish salvage and relocation operations are complete, Midas Gold will completely divert the flow of the EFSFSR into the tunnel and commence draining the Yellow Pine pit lake.

precipitation and excess pumped contact stormwater runoff. There will be a minor demand for water during construction and preproduction mining for dust control; however, most of the contact water generated during construction will be appropriately managed and/or treated and discharged. Discharge from the temporary treatment system(s) will be routed to an IPDES outfall at the Plant site. Discharge from the sanitary WWTP will be routed to an IPDES outfall at the worker housing facility. Figure 2-1 shows the locations of the proposed IPDES outfalls.

Water quality during construction will be managed through the provisions and requirements of the MSGP, as it has been during Midas Gold's exploration period since 2013. An updated Notice of Intent and SWPPP will be submitted providing pertinent construction details pursuant to water quality management. Midas Gold anticipates working with the United States Environmental Protection Agency (EPA) and State to determine which facets of the SGP will be covered under an IPDES permit and which facets will be eligible for coverage under the MSGP. These discussions will be based upon the constraints and provisions associated with each permit using site-specific data and reasonable and protective assumptions. That process cannot be substantially advanced until a preferred alternative is selected since both permits require specific details regarding construction and the quality and quantity of water sources identified in the plan.

### 2.3.2 Water Management – Operations

The SGP consists of three pits (Yellow Pine pit, Hangar Flats pit, and West End pit) that will generally be mined in that order during the 12+ years of mine operations. The focus of water management during operations will be to divert clean water around mine facilities, ensure water supply for the ore processing facility, and manage excess contact water as described below:

- Clean water diversion: Clean water diversions installed during construction will be maintained, and additional diversions constructed, to divert upgradient clean water around mine facilities. Major diversions include the diversion of Meadow Creek around Hangar Flats pit in a lined, vegetated stream/floodplain corridor; the EFSFSR tunnel/fishway around the Yellow Pine pit; and the diversions of Meadow Creek and tributaries around the TSF and Hangar Flats DRSF. Additional smaller scale diversions of upslope runoff will be added as mining and development rock placement advances.
- Process water requirements: When the ore processing facility is first commissioned, fresh water and stored contact water runoff will be used until reclaim water from the TSF becomes available. During initial operations, water that accumulates in the TSF supernatant pond will be recycled to the ore processing facility as sufficient quantities become available. Snowmelt and rain falling on the TSF will add water to the supernatant pond, especially in the spring. Makeup water will be supplied from stored contact water, water supply wells, and pit dewatering wells. After the first year of operations, the majority of water needed for ore processing will be recycled from the TSF, thereby reducing the need for makeup water.
- Contact water management: The contact water management system will consist of a series of contact water storage ponds with a ditch, pipeline, and pumping system to move contact water to either the mill, centralized WTP (described herein), or to another pond or open pit depending on the operational strategy and site conditions.
- Two types of ponds will be used: (1) ponds that receive only pumped mine drainage from an open pit or equalization flow from other contact water ponds, and (2) ponds that primarily receive direct surface runoff (contact water stormwater and/or snowmelt) from mine features and may receive pumped flow for equalization. Preliminary sizing and design criteria for the contact water ponds are summarized in Table 2-1. Ponds receiving primarily direct surface runoff were initially sized to manage the 100-year, 24-hour design event at a minimum, while

ponds receiving pumped mine drainage and contact water were sized based on available space for equalization. Ponds will be located in the proximity of water generating features where space is available, including at the toe of the Hangar Flats and Fiddle DRSFs, near the Yellow Pine and West End pits, within the disturbance area for the Hangar Flats pit during the early years of operation, and near the Plant site where contact water will be used and treated. The contact water ponds excavated in alluvium, till, etc., and their embankments, will be lined with a geomembrane (high-density polyethylene or similar) underlain with geotextile as needed according to subgrade conditions. Water collection sumps excavated within mine feature footprints in low-permeability material (e.g., rock in pits, legacy tailings, already-lined facilities) will not require additional liner. Design details, typical cross sections, and pond locations will be provided in the Water Management Plan once a preferred alternative is selected.

- Pit dewatering: Excess dewatering water not used at the mill to meet the high-quality demand will be treated and discharged to RIBs to support alluvial groundwater levels and streamflow in lower Meadow Creek valley.

Figure 2-3 shows the water sources and typical routing for operations during Year 7 (representative of the operations period when most of the facilities are built out and the peak runoff occurs). The routing diagram demonstrates generally how water will be managed during operations. Discharge from the central active treatment WTP will be routed to an IPDES outfall at the Plant site, while discharge from the sanitary WWTP will be routed to an IPDES outfall at the worker housing facility. The approximate IPDES outfall locations are shown on Figure 2-1.

Table 2-1. Design Criteria for Contact Water Storage Ponds

Design Criteria						
Pond ID	Phase	Maximum Capacity (ac-ft)	Freeboard (ft)	Minimum Design Capacity	Spillway Design Flow <sup>d</sup>	Facilities Served
<b>Ponds Receiving Only Pumped Storage</b>						
MD-1	Operations	82	2	Not applicable (N/A), sized based on available space <sup>a</sup>	Maximum inflow pumping capacity, plus 100-year, 24-hour design flow <sup>e</sup>	Yellow Pine pit, West End pit
PF-1	Operations	24	2	Not applicable (N/A), sized based on available space <sup>a</sup>	Maximum inflow pumping capacity, plus 100-year, 24-hour design flow <sup>e</sup>	Yellow Pine pit, West End pit
HFP-1	Operations	232	3	Not applicable (N/A), sized based on available space <sup>a</sup>	Maximum inflow pumping capacity, plus 100-year, 24-hour design flow <sup>e</sup>	Overflow storage for ponds BT-1, HF-1, HF-2, HF-3, and TS-1
<b>Ponds Receiving Primarily Surface Runoff</b>						
HF-1	Construction, Operations	8	2	100-year, 24-hour design event <sup>b</sup>	100-year, 24-hour design event with snowmelt	Hangar Flats DRSF
HF-2	Operations	8	2	100-year, 24-hour design event <sup>b</sup>	100-year, 24-hour design event with snowmelt	Hangar Flats DRSF
HF-3	Operations	130	3	100-year, 24-hour design event <sup>c</sup>	100-year, 24-hour design event with snowmelt	Hangar Flats DRSF
FD-1	Operations, Post-Closure	28	2	100-year, 24-hour design event	100-year, 24-hour design event with snowmelt	Fiddle DRSF
BT-1	Construction, Operations	7	2	100-year, 24-hour design event	100-year, 24-hour design event with snowmelt	Bradley tailings removal
TS-1	Construction, Operations	24	2	100-year, 24-hour design event <sup>c</sup>	100-year, 24-hour design event with snowmelt	Hecla heap removal, Hangar Flats pit

## Notes:

a Minimum design capacity criteria not applicable for ponds receiving pumped contact water. Pond sized based on available space to allow for excess equalization storage.

b Ponds HF-1 and HF-2 were sized based on available space at the toe of the Hangar Flats DRSF. The design storm volume will be met with the pond volume and a larger pump capacity, with overflow routed to HFP-1.

c Pond oversized above the minimum sizing requirement based on available space to allow excess for additional equalization storage.

d Spillway overflow will be routed to nearest open pit for emergency short-term storage.

e Spillway design flow for ponds receiving pumped storage based on peak inflow pumping rate and precipitation falling directly on the pond. Upgradient surface water will be diverted around such ponds.

## Abbreviations:

ac-ft = acre feet

DRSF = development rock storage facility

Ft = foot/feet

ID = identifier

N/A = not applicable

TSF = tailings storage facility



### 2.3.3 Water Management – Reclamation, Closure, and Post-Closure

The time between the end of mine operations and post-closure is referred to as the reclamation and closure period. For the purposes of this document, the reclamation and closure period was assumed to refer to the period from Years 13 to 18. Reclamation and closure activities include concurrent reclamation during operations and interim reclamation for the first 5 years after ore processing concludes. The post-closure period will start in Years 18 to 21, depending on operating life. During reclamation, streams will be restored to conditions beneficial for fisheries and aquatic life, with most reclamation activities completed within 5 years of the end of mining operations. Details regarding reclamation and restoration of the streams is described in several documents including the PRO (Midas 2016), water management narrative (BC 2018c), ModPRO Technical Memorandum (BC 2019), Conceptual Mitigation Plan (Tetra Tech 2019), and Stream Design Report (Rio Applied Science and Engineering 2019). Water management during reclamation will be focused on dewatering the TSF to reclaim the facility and install the cover, re-establishing streams, and managing inflows and outflows of open pits. Key activities during reclamation impacting water management include the following:

- Partially backfill the Hangar Flats pit with development rock from the West End pit commencing in Year 11.
- Cease dewatering of Hangar Flats pit in late operations (Year 11) and West End pit at end of operations, resulting in the eventual formation of pit lakes. Hangar Flats pit lake filling will be accelerated by diverting a portion of the spring peak flows from Meadow Creek.
- Taper dewatering at Yellow Pine pit during backfilling in late operations to maintain an unsaturated backfill surface during reclamation. Continue minimal dewatering from the Yellow Pine pit wells and discharge to the RIBs following treatment during Hangar Flats lake filling to support alluvial groundwater levels in lower Meadow Creek valley.
- Backfill Yellow Pine pit (during operations) and reconstruct the EFSFSR channel and floodplain across the backfill to allow for restoration of the EFSFSR, lower Hennessy Creek, and lower Midnight Creek across the backfill.
- Place engineered cap and re-establish Fiddle Creek across the Fiddle DRSF and reconnect with lower Fiddle Creek.
- Re-establish West End Creek, the upper portion of which will flow into the West End pit forming a small pit lake.
- Reclaim and cap the top of the TSF embankment/Hangar Flats DRSF.
- Dewater TSF supernatant pond, cover and reclaim the TSF, and restore Meadow Creek and tributaries across the top of the TSF.
- Backfill Midnight pit.

Figure 2-4 shows the water sources and typical routing for post-closure (starting in Year 18 to 21, depending on operating life) to represent the general water management approach during the reclamation, closure and post-closure periods. While impacted flows after operations will be minimized, there will still be mine-impacted waters to be managed through a combination of operational strategies and treatment, described in detail in the following sections. Mine-impacted flows after operations include TSF consolidation water, Fiddle DRSF toe seepage, and Hangar Flats and West End pit lake overflows. Discharge from the central active WTP will be routed to the IPDES outfall at the Plant site. Discharge from the passive treatment systems will be routed to IPDES outfalls located downstream of the facilities, to be confirmed through the IPDES permit renewal process. The approximate locations of the IPDES outfalls for reclamation and post-closure are shown on Figure 2-1. The actual locations will be determined through the IPDES process prior to reclamation.

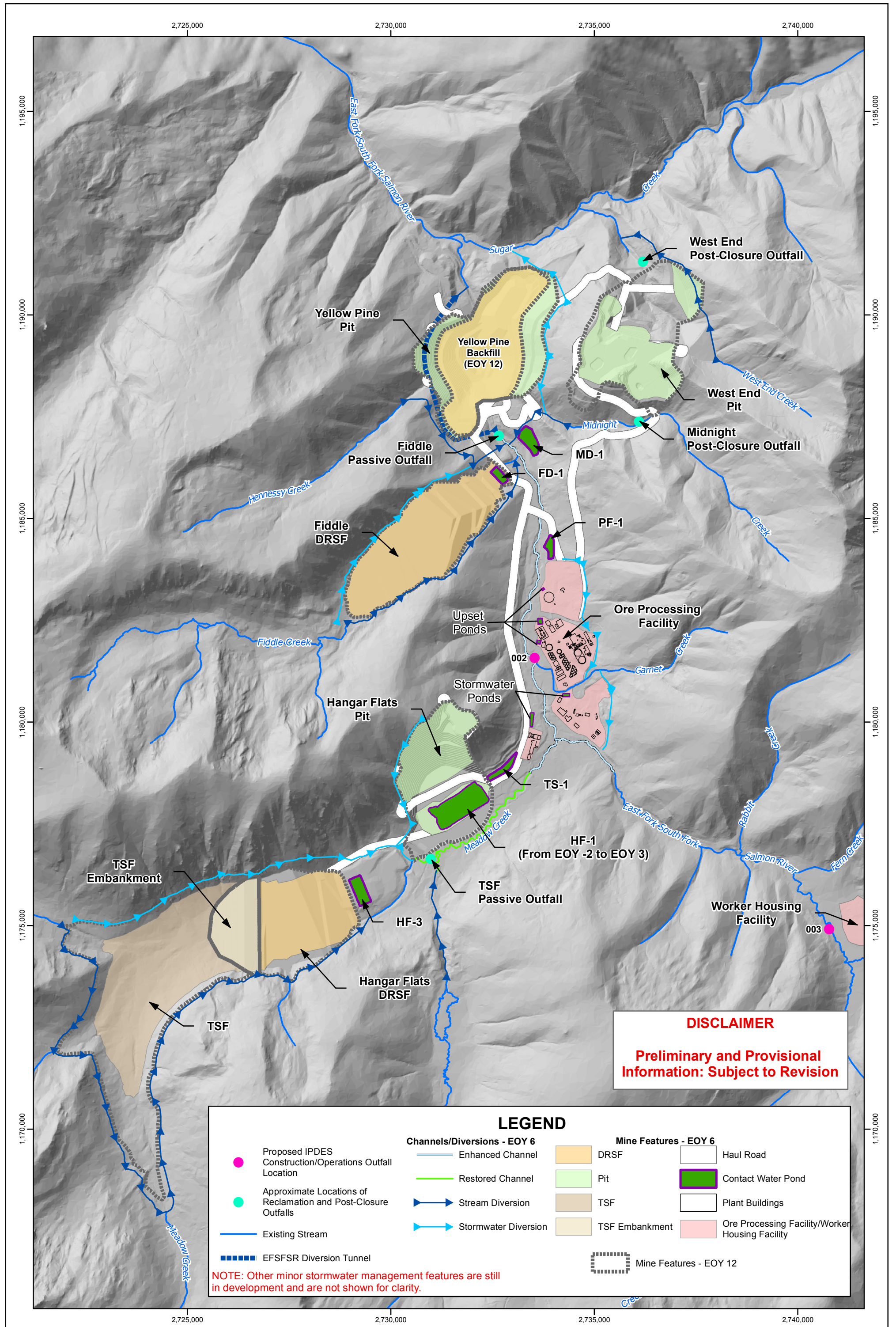

**DISCLAIMER**  
**Preliminary and Provisional Information: Subject to Revision**

**LEGEND**

<ul style="list-style-type: none"> <li><span style="color: magenta;">●</span> Proposed IPDES Construction/Operations Outfall Location</li> <li><span style="color: cyan;">●</span> Approximate Locations of Reclamation and Post-Closure Outfalls</li> <li><span style="color: blue;">—</span> Existing Stream</li> <li><span style="color: blue;">▬▬▬▬</span> EFSFSR Diversion Tunnel</li> </ul>	<p><b>Channels/Diversions - EOY 6</b></p> <ul style="list-style-type: none"> <li><span style="color: blue;">—</span> Enhanced Channel</li> <li><span style="color: green;">—</span> Restored Channel</li> <li><span style="color: blue;">▶</span> Stream Diversion</li> <li><span style="color: blue;">▶▶</span> Stormwater Diversion</li> </ul>	<p><b>Mine Features - EOY 6</b></p> <ul style="list-style-type: none"> <li><span style="background-color: orange; border: 1px solid black; display: inline-block; width: 15px; height: 10px;"></span> DRSF</li> <li><span style="background-color: lightgreen; border: 1px solid black; display: inline-block; width: 15px; height: 10px;"></span> Pit</li> <li><span style="background-color: tan; border: 1px solid black; display: inline-block; width: 15px; height: 10px;"></span> TSF</li> <li><span style="background-color: lightyellow; border: 1px solid black; display: inline-block; width: 15px; height: 10px;"></span> TSF Embankment</li> </ul>	<ul style="list-style-type: none"> <li><span style="border: 1px solid black; display: inline-block; width: 15px; height: 10px;"></span> Haul Road</li> <li><span style="background-color: green; border: 1px solid black; display: inline-block; width: 15px; height: 10px;"></span> Contact Water Pond</li> <li><span style="border: 1px solid black; display: inline-block; width: 15px; height: 10px;"></span> Plant Buildings</li> <li><span style="background-color: pink; border: 1px solid black; display: inline-block; width: 15px; height: 10px;"></span> Ore Processing Facility/Worker Housing Facility</li> </ul>
---	--	--	--

Mine Features - EOY 12

NOTE: Other minor stormwater management features are still in development and are not shown for clarity.



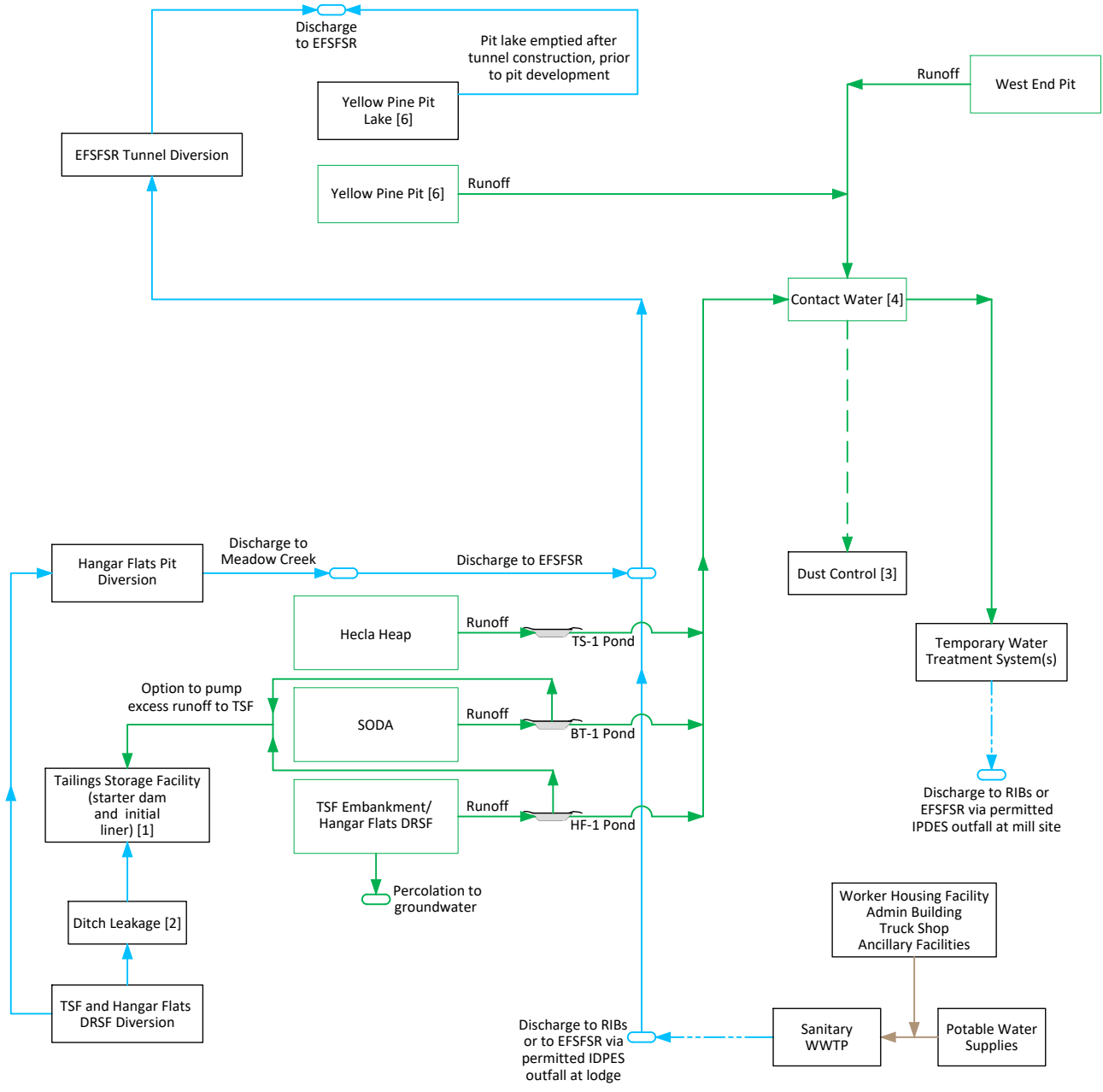

- Legend**
- Fresh water
  - Contact water
  - Domestic water
  - Treated water
  - - - Minor component of split stream
  - ↔ Flow split
  - System end point\*

\*Losses to atmosphere not shown as sinks for clarity. This category includes evaporation, transpiration, sublimation, and steam generation from the process. Precipitation is also not shown.

- Notes:**
- [1] Water collected in the TSF starter dam will be used to meet mill startup water demand.
  - [2] Ditch leakage in Year -1 will be managed during construction until the TSF liner is in place to allow for accumulation of water for the mill start up.
  - [3] Contact water may be used for dust suppression on in-pit haul roads and DRSFs.
  - [4] Contact water flows will be equalized through a system of contact water storage ponds prior to treatment.
  - [5] Flow routing based on Modified Plan of Restoration and Operations (ModPRO), Alternative 2 in the Environmental Impact Statement (EIS).
  - [6] Yellow Pine pit disturbance outside of Yellow Pine pit lake in Year -1. Yellow Pine pit lake expected to be emptied by end of Year -1.

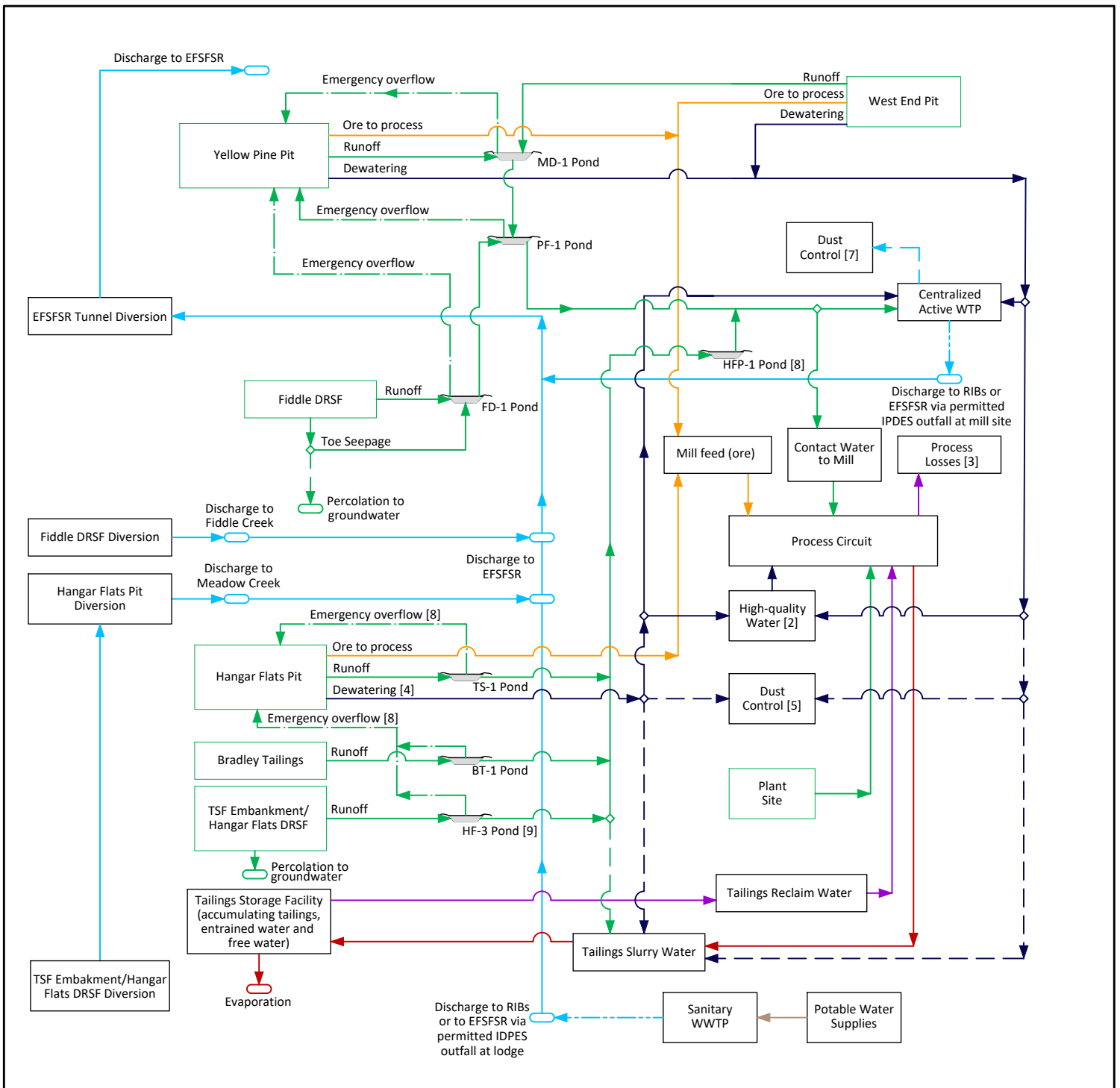

- Notes:
- [1] Contact water system will have flexibility during operation. A preferred flow path is shown.
  - [2] Process fresh water (high-quality water) requirements include: elution makeup, crusher dust control, gland seals, autoclave steam makeup, and reagents [lime slaking, flocculant mixing, NaCN, NaOH, Pb(NO<sub>3</sub>)<sub>2</sub>, CuSO<sub>4</sub>, and Na<sub>2</sub>SO<sub>5</sub>]. CCD cooling tower makeup uses process water. Additional intermittent flows excluded. High-quality water demand can be supplied from either the Yellow Pine or Hangar Flat pit dewatering well fields.
  - [3] Process losses (consumptive uses) include: Sb concentrate, autoclave flash, cooling tower, lime slaking, ADR and kiln stack, sludge drying, Ca(SO<sub>4</sub>)<sub>2</sub> precipitation.
  - [4] Dewatering includes water removed using groundwater wells for pit dewatering and minimal groundwater flow reporting to the bottom of the open pit.
  - [5] Contact water may be used for dust control for in-pit haul roads and DRSFs.
  - [6] Flow routing based on Modified Plan of Restoration and Operations (ModPRO), Alternative 2 in the Environmental Impact Statement (EIS).
  - [7] Treated water may be used for dust control on out-of-pit haul roads and other non-contact areas.
  - [8] HFP-1 Pond is in place from mine year -1 to 6, to provide contact water equalization and will serve as the emergency overflow in lieu of Hangar Flats pit.
  - [9] HF-1 and HF-2 (not shown on schematic) will be constructed to manage Hangar Flats DRSF runoff before HF-3 is constructed.

**Legend**

- Fresh water
- Dewatering water
- Contact water
- Ore (with associated moisture)
- Process water
- Tailings slurry
- Domestic water
- Treated water
- Emergency overflow spillway
- Minor component of split stream
- ◇ Flow split
- System end point\*

\*Losses to atmosphere not shown as sinks for clarity. This category includes evaporation, transpiration, sublimation, and steam generation from the process. Precipitation is also not shown.



Date: 3/27/2020  
 Project No: 154520  
 Client: Midas Gold

Figure 2-3  
 Flow Diagram for Operations  
 Typical Mine Year  
 Stibnite Gold Project

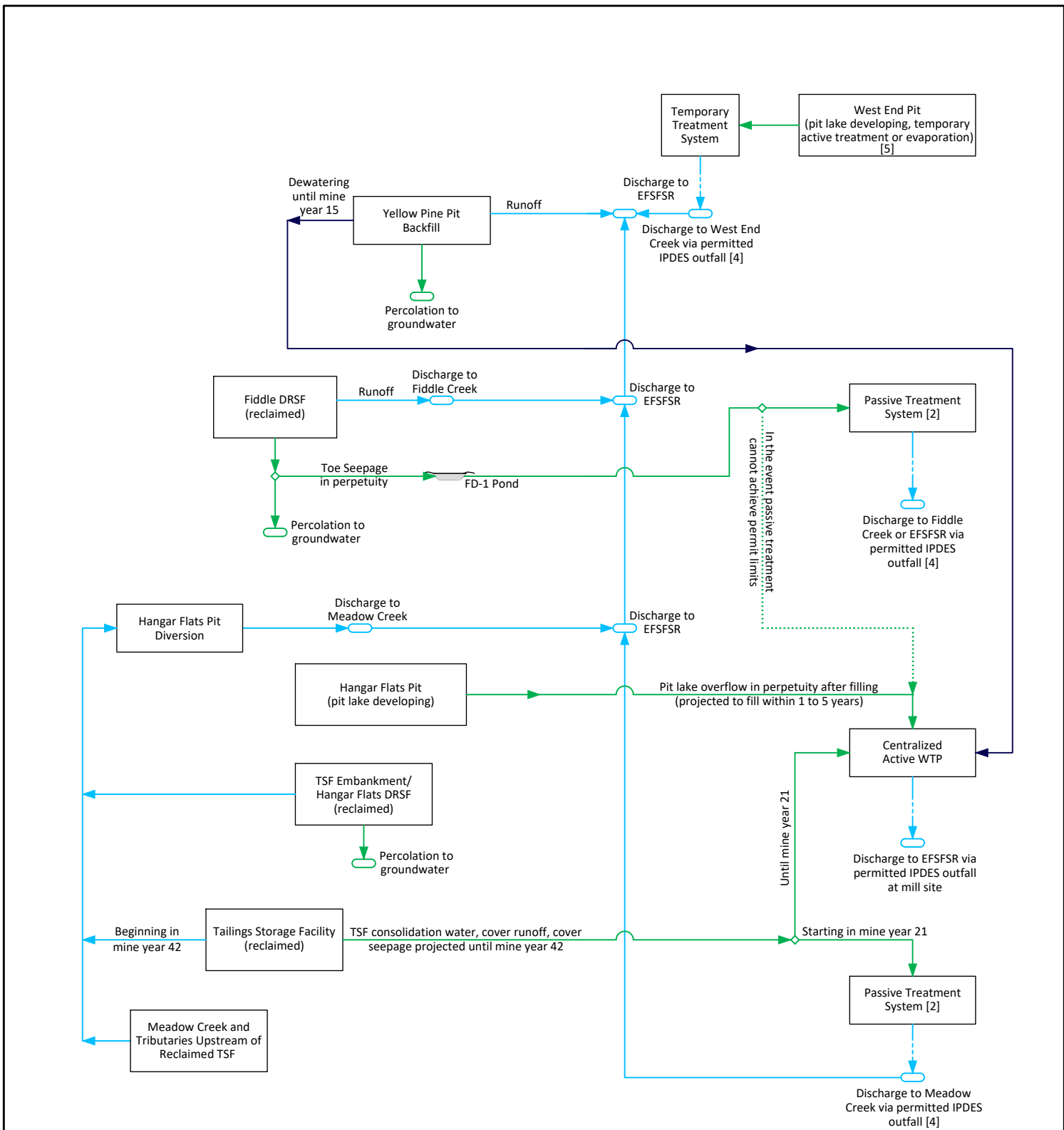

- Legend**
- Fresh water
  - Contact water
  - Dewatering water
  - Treated water
  - Alternative flow routing option
  - ◇ Flow split
  - System end point\*

\*Losses to atmosphere not shown as sinks for clarity. This category includes evaporation, transpiration, sublimation, and steam generation from the process. Precipitation is also not shown.

- Notes:**
- [1] Flow routing based on Modified Plan of Restoration and Operations (ModPRO), Alternative 2 in the Environmental Impact Statement (EIS).
  - [2] The passive treatment systems will require pilot testing for effectiveness to meet treatment objectives. In the event passive treatment system cannot meet the treatment objectives, continued use of active treatment is planned.
  - [3] Closure is anticipated to begin sometime between mine years 18 and 21.
  - [4] IPDES outfalls will be located via the IPDES process during permit renewals.
  - [5] Operated periodically to maintain lake level below setpoint.

## 2.4 Treatment Premise

This Plan is based on the following decisions and assumptions that comprise the treatment premise:

- Treat all contact water that is to be discharged directly to surface waters or RIBs to the extent required to meet IPDES requirements, except stormwater runoff from areas of the mine eligible for coverage under the MSGP.
- During operations, process water/TSF water will not need to be discharged and, thus, will not require treatment. The TSF is a zero-discharge facility that will be designed and operated, along with ore processing, as a closed circuit (Midas 2016).
  - If the tailings pumping system is taken offline, the ore processing facility will also be taken offline. In the event of a facility shutdown (unexpected or in the course of normal operations such as planned maintenance outages), reclaim from TSF would cease, pumping from contact water ponds to the ore processing facility would cease, and excess water would be directed to contact water ponds, the pipeline drainage pond, and/or one of the open pits (for extended periods of downtime). Redundant tailings slurry pumps will be installed, additional spares will be warehoused on site, and the ore processing facility can safely store all water contained within the pipes and tanks.
- To account for seasonal variability in stormwater runoff, store contact water in interconnected contact water storage ponds prior to treatment in the WTP.
- Design the water treatment system (WTP and storage ponds) with sufficient capacity to manage seasonal flow variability.
- Size the WTP with the consideration that flows during the spring snowmelt period that occur in an extremely wet year (e.g., the 95th percentile wet weather year) may be temporarily stored in the mine pits to reduce the maximum instantaneous flow rate to the treatment system.
  - Given the dominance of snowpack and snowmelt runoff on both instantaneous peaks of streamflow and contact water yield, the circumstances requiring the use of mine pits for contact water storage would not be unexpected and would be planned for in high-water years. There will be flexibility in scheduling to prevent mining in the bottom of pits during these periods. The effects can also be mitigated with stockpiling. Depending on mine phase, there would also be multiple pit options for storage. Lastly, the ore processing facility must be shut down periodically for maintenance, and this could be scheduled during expected high-runoff periods.
- Use temporary systems in the years when the peak monthly flow is less than 1,000 gallons per minute (gpm). This includes the mine construction period and Years 1 to 3.
- Begin using a larger, more permanent centralized WTP, to the extent feasible, during years when the peak monthly flow is 1,000 gpm or more. Flow projections indicate operation of the centralized WTP commencing in Year 4.
- Preliminary engineering of the centralized WTP begins 3 years in advance of need, followed by construction.
- During operations, send WTP residuals to the TSF. The quantity of solids and dissolved constituents sent from the WTP to the TSF will be very small when compared with the amount of tailings sent from the mill to the TSF (2 tons per day of WTP residual compared to 20,000 to 25,000 tons per day of tailings). Toxicity characteristic leaching procedure (TCLP) testing will be conducted to determine if the residuals will be considered hazardous waste; however, based on current information, the residuals sent to the TSF are not expected to be classified as hazardous waste.

- During mine operations, pilot test passive treatment and, if feasible, convert to passive treatment during closure or post-closure once flows are sufficiently low.

Based on the treatment premise outlined above, multiple treatment systems will provide treatment at the Project site through mine construction, operations, reclamation, and post-closure as presented in Table 2-2. The treatment systems and timing of treatment listed in the table are described in detail in Section 7 and Section 8.

Midas Gold is aware that, in addition to complying with Idaho surface water standards, the SGP is also subject to the Effluent Limitation Guidelines (ELGs) as codified in the New Source Performance Standards for gold mines at 40 CFR 440.104. The parameters with ELGs are pH, total suspended solids, cadmium, copper, lead, mercury, and zinc.

## 2.5 Ambient Surface Water Quality

Ambient surface water quality in some stream reaches in the Stibnite Mining District in and around the Project site includes concentrations of some constituents—particularly arsenic, antimony, and mercury—at levels well above some Idaho surface water criteria (Etheridge 2015; Midas Gold 2019). This Plan is designed to address the quality of water from sources that may be impacted by Midas Gold’s activities at the site. Midas Gold is committed to ensuring that such water is managed and or treated to comply with IPDES permit limits for discharges to surface waters, but the Plan does not necessarily address elevated constituent concentrations originating from areas that will not be disturbed by Midas Gold’s activities.

In addition, certain proposed actions by Midas Gold are expected to reduce or remove legacy sources of contamination, which should improve overall water quality in the EFSFSR drainage upstream of the Sugar Creek confluence (Midas Gold 2016). However, while overall water quality in the Project site should improve, it may not be possible to reduce overall concentrations in surface waters to concentrations below applicable Idaho criteria because: (1) the water expected to be managed and treated by Midas Gold is a small proportion of the overall surface water flowing through the Project site in the EFSFSR and its tributaries (Section 3.1, BC 2017), and (2) there are naturally<sup>6</sup> mineralized conditions over several square miles within the vicinity of the site (Midas Gold 2016).

---

<sup>6</sup> Idaho defines “natural background conditions” as “The physical, chemical, biological, or radiological conditions existing in a water body without human sources of pollution within the watershed.” (IDAPA 010.63). They use the term in the narrative criteria in IDAPA 200.09 as “When natural background conditions exceed any applicable water quality criteria set forth in Sections 210, 250, 251, 252, or 253, the applicable water quality criteria shall not apply; instead, there shall be no lowering of water quality from natural background conditions.” Natural background conditions could be used by IDEQ to set site-specific alternative criteria (IDAPA 275.01), which can take time. The WQMP does not contain an assessment of natural background conditions, as that evaluation is preliminary.

**Table 2-2. Proposed Water Treatment Schedule (assuming 12-year mine operations period<sup>a</sup>)**

Treatment Method	Mine Phase and Year																								
	Construction			Mine Operations												Reclamation					Post-Closure				In Perpetuity
	-3	-2	-1	1	2	3	4	5	6	7	8	9	10	11	12	13	14	15	16	17	18	19	20	21-42	
Enhanced Evaporation	-	X	X	X	X	X	X	X	X	X	X	X	X	X	X	X	X	X	X	X	-	-	-	X	X
Membrane and Iron Coprecipitation Technology Confirmation	X	-	-	-	-	-	-	-	-	-	-	-	-	-	-	-	-	-	-	-	-	-	-	-	-
Rented/Temporary Iron Coprecipitation Treatment System	-	X	X	-	-	-	-	-	-	-	-	-	-	-	-	-	-	-	-	-	-	-	-	-	-
Rented/Temporary Membrane Treatment System	-	-	-	X	X	X	-	-	-	-	-	-	-	-	-	-	-	-	-	-	-	-	-	-	X
Centralized Active WTP	-	-	-	-	-	-	X	X	X	X	X	X	X	X	X	X	X	X	X	X	X	X	X	X	X
BCR and Wetland Technology Confirmation Testing	-	-	-	-	-	-	-	-	-	-	X	X	X	X	X	-	-	-	-	-	-	-	-	-	-
Passive Treatment System (TSF Consolidation Waters Only)	-	-	-	-	-	-	-	-	-	-	-	-	-	-	-	-	-	-	-	-	-	-	X	-	
Passive Treatment System (Fiddle DRSF Toe Seepage Only)	-	-	-	-	-	-	-	-	-	-	-	-	-	-	X	X	X	X	X	X	X	X	X	X	X
Sanitary WWTP	-	X	X	X	X	X	X	X	X	X	X	X	X	X	X	X	X	X	X	X	-	-	-	-	-

Notes:

<sup>a</sup> If mine operations extend to Years 13-15, then reclamation and post-closure would be delayed accordingly.

Abbreviations:

BCR = biochemical reactor

DRSF = development rock storage facility

TSF = tailings storage facility

WTP = water treatment plant

WWTP = wastewater treatment plant



## 2.6 Adaptive Management

Adaptive management is commonly used in mining because large, complex mining operations that span several decades evolve over time as new areas are developed and older ones are reclaimed, and often experience new or unanticipated conditions that require operational flexibility later in the life of the SGP. Examples include environmental effects being somewhat different than expected, water quality or quantity being different than modeled, new information or technology becoming available, or the effectiveness of mitigation measures and approaches being adjusted or improved for better outcomes. Midas Gold will use an adaptive management framework for implementation of the Plan and to achieve water management objectives described previously. This approach recognizes the environmental risks and the dynamic nature of mining operations and allows them to be addressed in a systematic, planned, and documented manner through actions, evaluation, and adjustments.

Adaptive management for water quality management will begin in the design stages from technology confirmation, bench studies, feasibility study, and engineering design, as Midas Gold uses new information and findings to improve process effectiveness and efficiency. It will continue through construction, operations, monitoring and response, and into the transition to treatment during post-closure. Short-term and long-term monitoring will be required to assess how the mine water changes under different conditions, and how mine water treatment needs to be adapted to these changes. Furthermore, developments in mine water treatment technologies also need to be considered when assessing the potential for evolution of a mine water treatment scheme. For long-term mine water management, all these aspects need to be considered holistically and, where possible, it is advantageous to recognize the potential for future changes to treatment to be accommodated in an existing treatment scheme. Figure 2-5 is provided to graphically describe the iterative approach of adaptive management.

In addition to water quality and treatment, implementation of water management and collection will similarly be subject to adaptive management. This will particularly apply to subsurface flow management—dewatering and groundwater drainage. For example, modeling to date (BC 2019b) indicates that groundwater levels during operations and post-closure will be below the base of the Hangar Flats DRSF, and in combination with design features such as the lined diversions and ultimately a low-permeability cap at closure, support an expectation that drains installed beneath that facility would remain virtually dry, and toe seepage would be minimal. In addition, the Hangar Flats DRSF will mostly occupy the former SODA/Bradley tailings footprint. These legacy materials presently cover discrete seeps or springs that may underlie them, and their removal could change the underlying shallow hydrogeology making it difficult to design drains in advance. Once the SODA and Bradley tailings are removed, drains will be sited as necessary as an adaptive management measure, and will utilize a combination of perforated pipe, geosynthetics, gravel, and solid-wall pipe as appropriate to collect seeps/springs, and segregate clean and mine-impacted water. Underdrain water would be monitored and managed according to its water quality to meet water quality standards. The TSF underdrains would be installed during construction of the TSF, Bradley tailings removed completely by the 4th year of operations (roughly 7 years from start of construction), and the Hangar Flats DRSF completed in year 10; therefore, there would be numerous opportunities for observation and monitoring (of water flow, quality, and head in underdrains, wells, and piezometers), hydrologic model refinement, and adaptive management of DRSF drainage conditions. This potentially includes installing additional drains, collecting seeps and/or springs, and routing collected water to active or passive treatment, if warranted. Pit dewatering efforts would likewise be subject to ongoing adaptive management based on measurement and observation of dewatering performance, pit wall stability, water quality, and RIB performance.

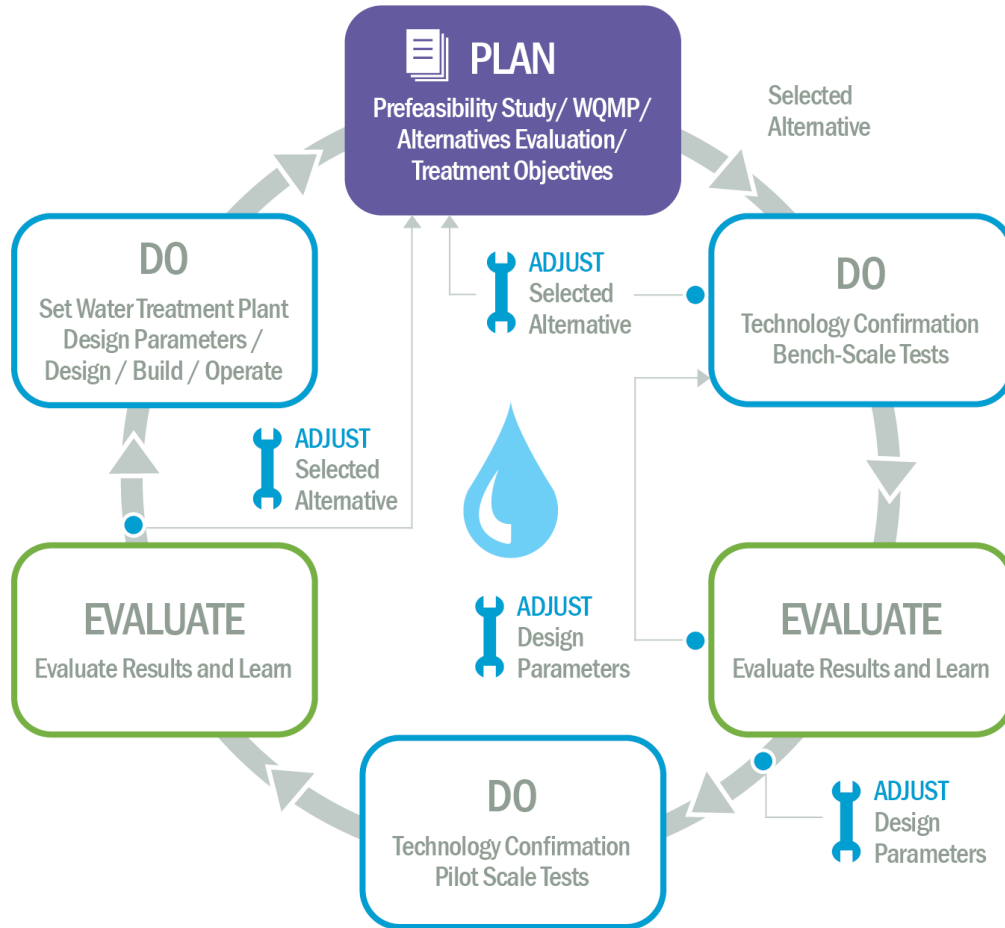

Figure 2-5. Adaptive Management Process

## Section 3

# Treatment System Flow Capacity

The projected contact water flow rates for treatment and/or evaporation throughout the mine life that will be used as the design basis for the water treatment evaluation are presented in this section.

### 3.1 Mine Construction and Operation Flows Summary

The Project site is in an interior mountainous region of Idaho where precipitation is dominated by winter snows and the highest runoff volumes are experienced during the subsequent spring snowmelt period. Because the spring snowmelt period yields the highest volumes of mine-impacted water entering the water management system, historical data for snowmelt periods were used as the basis for sizing flows to the WTP, rather than individual storm events.

The WTP design flow rate was developed using the volume of contact water generated in a maximum month during the spring snowmelt corresponding to the average and 95th percentile projections from the precipitation record. The projections were made for each year of the mine life. The monthly volume of contact water generated was converted to a flow rate based on flow being equal to volume divided by time. The projected maximum monthly flow estimates from individual mine features contributing contact water flow to the WTP during mine construction and mine operations are summarized in Table 3-1 and Table 3-2, respectively. Note that prior to disturbance of the legacy features listed in Table 3-1, stormwater runoff from these features will not be collected or treated. The annual average projected groundwater dewatering flow rate estimates during mine operations that contribute water to the WTP Table 3-3. The annual projected volumes of contact water and groundwater dewatering water for the average year condition are shown in Table 3-4.

As required for ore processing, a portion of these contact water and groundwater flows will be sent directly to the mill for use in the ore processing circuit. The remaining dewatering water will be sent directly to the WTP and the RIBs and the remaining contact water will be sent to a series of contact water ponds that will be used to equalize flows to the WTP and provide storage for water later to be used in the mill process. The projected storage volume available in the contact water ponds shown in Figure 2-1 for each year of mine construction and operations is shown in Table 3-5. The values presented in Table 3-5 represent the combined volumes for all the ponds available for each mine year. Additionally, during the spring snowmelt months, some portion of the flow may also be sent to the TSF where it can be reclaimed from the TSF for use in the ore processing circuit during subsequent lower-flow months of the year. Hence, the projected contact water and groundwater from both the average and the 95th percentile projections were reduced by the projected mill demands, equalization using the volume of contact water storage ponds, and partial flow diversion to the TSF. During extreme flow events, such as the spring snowmelt in the 95th percentile snowmelt year and simultaneous dewatering of more than one open pit, peak flows to the WTP will be further reduced by using the open mine pits and TSF to equalize the flow, if needed.

The resulting projected flow rates, volume of TSF diversion, and volume of in-pit storage, for these two water management regimes at the average and 95th percentile projections are presented in Table 3-5. This dual water management regime resulted in projected maximum month flows of 4,000 gpm for the average and 95th percentile runoff condition. Therefore, a maximum treatment system flow capacity of 4,000 gpm was selected as the design capacity of the WTP to manage up to the

95th percentile year condition in conjunction with the water management measures described herein. A water balance was performed on a monthly time-step for contact and dewatering waters going to the mill or the WTP. The results of this water balance are summarized on an annual basis in Table 3-7.

The treatment system capacity could be reduced if: (1) additional water management strategies are incorporated at the SGP, such as the planned use of enhanced evaporation; (2) observed water quality proves better than model predictions or improves over time; or (3) contact water volumes or pit dewatering volumes are less than predicted. Additionally, if an unexpected increase in treatment system capacity is needed, based on the observed snowpack prior to the spring snowmelt period, temporary mobile treatment systems can be brought to the Project site for additional capacity. It should specifically be noted that the calculations used for design flow development do not consider potential reductions in contact water volumes discharged from the storage ponds, which may be reduced by using enhanced evaporation during storage. While the items noted above indicate that this is possibly a conservative estimate of the volume to be treated, there remain uncertainties in the predicted mine water balance and the predictive chemistry modeling, and potential changes due to climate change. Adaptive management of the design basis will allow for updating the design basis as information around these uncertainties continues to be developed.

**Table 3-1. Maximum Month Contact Water Flow Rates by Source during Mine Construction**

Maximum Month Flow Rate (gpm)												
Mine Year	SODA Drainage		Hecla Heap Surface Runoff		West End Pit Water		Yellow Pine Pit Water		Hangar Flats DRSF and TSF Embankment Runoff		Combined Maximum Month Flow Rate	
	Average Year	95th PCTL Year	Average Year	95th PCTL Year	Average Year	95th PCTL Year	Average Year	95th PCTL Year	Average Year	95th PCTL Year	Average Year	95th PCTL Year
-3	0	0	0	0	0	0	0	0	0	0	0	0
-2	0	0	0	0	0	0	0	0	24	45	24	45
-1	107	367	59	88	34	50	37	55	52	122	288	682

*Abbreviations:*

*DRSF = development rock storage facility*

*gpm = gallon per minute*

*PCTL = percentile*

*SODA = spent ore disposal area*

*TSF = tailings storage facility*



**Table 3-2. Projected Maximum Month Contact Water Flow Rates by Source During Operations (assuming a 12- year mine operations period)**

Mine Year	Maximum Month Flow Rate (gpm) <sup>d</sup>																	
	Hangar Flats Pit Water		West End Pit Water		Yellow Pine Pit Water		Hangar Flats DRSF and TSF Embankment Runoff		Fiddle DRSF Runoff		Fiddle DRSF Toe Seepage		Bradley Tailings Runoff		Plant Area Stormwater Runoff		Combined Maximum Month Flow Rate <sup>b, c</sup>	
	Avg Year	95th PCTL Year <sup>a</sup>	Avg Year	95th PCTL Year <sup>a</sup>	Avg Year	95th PCTL Year <sup>a</sup>	Avg Year	95th PCTL Year	Avg Year	95th PCTL Year	Avg Year	95th PCTL Year	Avg Year	95th PCTL Year	Avg Year	95th PCTL Year	Avg Year	95th PCTL Year
1	130	237	101	175	82	149	37	95	0	0	0	0	192	469	194	437	736	1,563
2	165	293	147	266	239	389	33	74	9	18	33	45	129	318	196	448	951	1,850
3	226	403	164	296	530	927	55	127	39	84	740	705	87	210	196	437	1,965	3,055
4	263	472	171	309	747	1,323	76	174	76	172	641	605	41	109	196	437	2,166	3,601
5	313	556	241	418	866	1,573	92	217	101	234	770	727	0	0	195	437	2,516	4,064
6	395	716	383	685	884	1,628	99	234	123	292	750	814	0	0	197	448	2,787	4,818
7	523	917	482	863	885	1,599	108	250	128	302	844	960	0	0	197	437	3,167	5,328
8	626	1,133	525	946	0	0	126	290	66	178	812	819	0	0	196	437	2,352	3,738
9	623	1,133	595	1,062	0	0	150	352	0	0	843	985	0	0	195	437	2,406	3,899
10	625	1,154	710	1,297	0	0	165	393	0	0	860	807	0	0	196	448	2,556	4,077
11	0	0	769	1,389	0	0	99	262	0	0	868	758	0	0	197	437	1,933	2,846
12	0	0	776	1,405	0	0	0	0	0	0	1,049	961	0	0	196	437	2,022	2,776

Notes:

<sup>a</sup> The flow rates presented are based on numbers originally developed in the Site Wide Water Balance (BC 2018a).

<sup>b</sup> The combined maximum month flow rate is a summation of all the flows during the given mine year in this table, and do not reflect management strategies to store water during the spring snowmelt period.

<sup>c</sup> The combined maximum month flow rate is not projected to change significantly for other alternatives considered in the Draft EIS.

<sup>d</sup> This table does not subtract water consumed in ore processing, which remains entrained in tailings.

Abbreviations:

Avg = average

PCTL = percentile

DRSF = development rock storage facility

TSF =tailings storage facility

EIS = Environmental Impact Statement

gpm = gallon per minute



**Table 3-3. Average Annual Groundwater Dewatering Flow Rates by Source During Mine Operations  
(assuming a 12-year mine operations period)**

Mine Year	Average Annual Flow Rate (gpm) <sup>a</sup>			
	Yellow Pine Dewatering	Hangar Flats Dewatering	West End Dewatering	Combined Volume
1	1,193	0	0	1,193
2	1,408	2	0	1,410
3	1,343	0	0	1,343
4	1,409	0	0	1,409
5	1,585	2	0	1,587
6	1,641	3	0	1,644
7	1,654	1,213	7	2,874
8	1,638	1,666	3	3,307
9	1,054	1,360	10	2,424
10	737	1,315	74	2,126
11	701	1,244	249	2,194
12	795	1,269	471	2,534

Notes:

<sup>a</sup> Estimated dewatering rates are based on the hydrologic modeling as presented in the ModPRO modeling report (BC 2019b). Once evaluation of the 2019 Aquifer Test results has been completed, the results may impact dewatering volumetric predictions.

Abbreviations:

*gpm* = gallon per minute

Table 3-4. Annual Projected Volumes of Contact Water and Groundwater Dewatering Water for the Average Year Condition

Source	Annual Volume (MG) by Mine Year														
	-3	-2	-1	1	2	3	4	5	6	7	8	9	10	11	12
<b>Contact Water Flows</b>															
Hangar Flats Pit Water	0	0	0	14	18	25	29	34	43	57	68	68	68	0	0
West End Pit Water	0	0	4	11	16	18	19	27	42	52	57	65	77	83	84
Yellow Pine Pit Water	0	0	4	9	27	58	82	94	96	96	0	0	0	0	0
Hangar Flats DRSF and TSF Embankment Runoff	0	2	4	3	3	5	6	8	8	9	10	13	14	8	0
Fiddle DRSF Runoff	0	0	0	0	1	3	6	8	10	11	5	0	0	0	0
Fiddle DRSF Toe Seepage	0	0	0	0	4	263	209	235	220	238	257	256	246	262	326
Bradley Tails Runoff	0	0	0	16	11	7	3	0	0	0	0	0	0	0	0
SODA Drainage	0	0	11	0	0	0	0	0	0	0	0	0	0	0	0
Hecla Heap Surface Runoff	0	0	7	0	0	0	0	0	0	0	0	0	0	0	0
Plant Area Stormwater Runoff	0	0	0	18	18	18	18	18	18	18	18	18	18	18	18
<b>Combined Contact Water Volume</b>	<b>0</b>	<b>2</b>	<b>31</b>	<b>71</b>	<b>97</b>	<b>396</b>	<b>371</b>	<b>424</b>	<b>437</b>	<b>480</b>	<b>415</b>	<b>419</b>	<b>422</b>	<b>371</b>	<b>427</b>
<b>Mine Pit Groundwater Dewatering Flows</b>															
Yellow Pine Dewatering	0	0	0	627	740	706	741	833	862	869	861	554	387	369	418
Hangar Flats Dewatering	0	0	0	0	1	0	0	1	1	637	876	715	691	654	667
West End Dewatering	0	0	0	0	0	0	0	0	0	4	2	5	39	131	247
<b>Combined Dewatering Volume</b>	<b>0</b>	<b>0</b>	<b>0</b>	<b>627</b>	<b>741</b>	<b>706</b>	<b>741</b>	<b>834</b>	<b>864</b>	<b>1,510</b>	<b>1,738</b>	<b>1,274</b>	<b>1,117</b>	<b>1,153</b>	<b>1,332</b>

**Abbreviations:**

DRSF = development rock storage facility

MG = million gallons

SODA = spent ore disposal area

TSF = tailings storage facility

**Table 3-5. Projected Combined Available Storage in the Contact Water Ponds (assuming a 12-year mine operations period)**

Mine Year	Total Volume Available <sup>a</sup>		Volume Available After Monthly Equalization <sup>b</sup>	
	Acre-feet	Million Gallons	Acre-feet	Million Gallons
-3	0	0	0	0
-2	0	0	0	0
-1	368	120	276	90
1	375	122	282	92
2	404	132	303	99
3	534	174	400	130
4	526	171	394	128
5	519	169	389	127
6	519	169	389	127
7	288	94	216	70
8	259	84	194	63
9	259	84	194	63
10	259	84	194	63
11	259	84	194	63
12	259	84	194	63

**Notes:**

<sup>a</sup> Total volume available is the total storage capacity available for the series of lined contact water ponds in operation during the given mine year. Ponds were sited in the proximity of water generating features where space is available, including at the toe of the Hangar Flats and Fiddle DRSFs, near the Yellow Pine and West End pits, within the existing disturbance area for the Hangar Flats pit in early years, and near the Plant site where contact water will be used and treated. Full pond details are under development and will be provided for review at a future date.

<sup>b</sup> 25 percent of the available storage was assumed to be reserved for equalization occurring on a time-step smaller than 1 month.

**Table 3-6. Flows for Water Treatment and/or Evaporation Following Flow Equalization Contact Water Ponds Partial Diversion to TSF and in Pit Storage**

Design Condition		Units	Mine Year														
			-3	-2	-1	1	2	3	4	5	6	7	8	9	10	11	12
95th Percentile Year Condition <sup>a</sup>	Maximum Month Flow	gpm	0	50	250	1,000	1,000	1,300	4,000	4,000	4,000	4,000	4,000	4,000	4,000	4,000	4,000
	Annual Average Flow	gpm	0	10	110	750	710	990	1,320	1,810	2,120	3,530	3,680	2,900	2,640	2,450	3,160
	Total Annual Volume	MG	0	0	60	400	370	520	690	950	1,120	1,860	1,930	1,520	1,390	1,290	1,660
	Volume Diverted to TSF <sup>c</sup>	MG	0	0	0	0	0	0	0	0	0	103	108	72	45	0	0
	Mine Pit Storage Utilized	MG	0	0	0	0	0	0	0	0	0	97	2	0	14	0	18
	Months with Utilized Pit Storage	Month	0	0	0	0	0	0	0	0	0	5	2	0	2	0	3
Average Year Condition <sup>b</sup>	Maximum Month Flow	gpm	0	20	250	1,000	710	1,000	2,780	3,420	3,790	4,000	4,000	4,000	4,000	4,000	4,000
	Annual Average Flow	gpm	0	0	60	580	510	700	960	1,440	1,590	3,040	3,240	2,440	2,100	2,190	3,080
	Total Annual Volume	MG	0	0	30	310	270	370	510	760	840	1,600	1,710	1,280	1,100	1,150	1,620
	Volume Diverted to TSF <sup>c</sup>	MG	0	0	0	0	0	0	0	0	0	72	0	0	11	0	0

Notes:

<sup>a</sup> 95th percentile year condition employs water management through equalization in contact water storage ponds, partial diversion of spring runoff to the TSF, and in-pit storage.

<sup>b</sup> Average year condition employs water management through equalization in contact water storage ponds and partial diversion of spring runoff to the TSF.

<sup>c</sup> A portion of spring runoff flows diverted to the TSF in April, May, and June.

<sup>d</sup> A This table does subtract water consumed in ore processing, which remains entrained in tailings.

Abbreviations:

gpm = gallon per minute

MG = million gallons

TSF = tailings storage facility



Table 3-7. Water Balance Summary for the Average Year Condition

Water Component	Annual Volume (MG) by Mine Year														
	-3	-2	-1	1	2	3	4	5	6	7	8	9	10	11	12
Contact Water Collected	0	2	31	71	97	396	371	424	437	480	415	419	422	371	427
Dewatering Water Collected	0	0	0	627	741	706	741	834	864	1,510	1,738	1,274	1,117	1,153	1,332
Contact Water and TSF Process Water Consumed at Mill	0	0	0	1,920	2,374	2,397	2,381	2,152	2,158	2,153	2,152	2,152	2,158	2,152	883
High Quality Process Water (i.e., Groundwater) Consumed at Mill	0	0	0	150	185	187	186	168	168	168	168	168	168	168	82
TSF Water to Mill	0	0	0	1,409	1,642	1,789	1,901	1,803	1,838	1,913	1,848	1,900	1,881	1,935	828
Contact Water to Mill	0	0	0	54	97	336	233	218	184	119	202	180	208	170	55
Contact Water to TSF	0	0	0	0	0	0	0	0	0	72	0	0	11	0	0
Dewatering Water to Mill for High Quality Process Water	0	0	0	150	185	187	186	168	168	168	168	168	168	168	82
Dewatering Water to Mill for Contact Water Makeup	0	0	0	190	292	211	188	115	112	35	78	62	54	37	0
Additional Makeup Water Needed at Mill <sup>a</sup>	0	0	0	266	343	61	59	16	24	16	24	11	5	11	0
Combined Water to Treatment (Temporary or WTP) <sup>b</sup>	0	2	31	304	264	368	505	757	836	1,597	1,706	1,284	1,098	1,150	1,622
Treated Water to RIBs	0	0	0	245	259	221	257	409	443	1,088	1,318	839	670	707	1,114
Treated Water to Surface Water Discharge Point	0	2	31	59	5	146	248	348	393	509	388	444	428	443	508

Notes:

<sup>a</sup> Supply wells will be utilized, as needed, to provide additional water to mill.

<sup>b</sup> Water to treatment is calculated as: (combined contact water volume – contact water to mill – contact water to TSF) + (combined dewatering volume – dewatering water to mill for high quality process water – dewatering water to mill for contact water makeup).

Abbreviations:

MG = million gallons

RIB = rapid infiltration basin

TSF = tailings storage facility

WTP = water treatment plant

## 3.2 Reclamation and Post-Closure Flows Summary

Following operations (i.e., during reclamation and post-closure), six contact water sources are expected to require treatment: (1) TSF supernatant pond water, (2) TSF consolidation water (a mixture of consolidation water, TSF cover seepage, and TSF surface runoff), (3) Yellow Pine pit dewatering water directed to RIBs, (4) Fiddle DRSF toe seepage, (5) Hangar Flats pit lake overflow, and (6) West End pit lake overflow. The design basis for the reclamation and post-closure flows is outlined in this section.

It should be reiterated that although the estimates presented here are based on best available data, adaptive management will be an important component of evaluating reclamation and post-closure flows and treatment requirements as information is gained through the mine operations period.

### 3.2.1 TSF Supernatant Pond Water

Following the cessation of mine operations, any remaining water in the TSF supernatant pond will either be mechanically evaporated or treated and discharged. As Midas Gold approaches the reclamation phase of the SGP, as much water as practical will be drawn from the TSF supernatant pond and used in the mill, and less makeup water will be added to the system, thereby reducing the size of the TSF supernatant pond. Therefore, it is assumed that the quantity of water to be treated or evaporated will be near the minimum volume of the TSF supernatant pond, which is 3.1 million gallons (9.6 acre-feet).

The rate at which the supernatant pond water will be removed and treated for discharge will be limited by 40 CFR 440.104, which requires that the volume of treated water discharged not exceed the difference between precipitation on the TSF and any areas contributing to it and evaporation from the same areas on an annual basis. For the purposes of the WTP design basis, it was assumed that the TSF supernatant pond will be dewatered over a 3-month period at an average flow rate of approximately 25 gpm. The 3-month TSF supernatant dewatering period will remove supernatant water remaining after operations, Midas Gold expects tailings to continue to consolidate after the TSF supernatant pond is dewatered.

### 3.2.2 TSF Post-Closure Consolidation Waters

During mine reclamation and post-closure, tailings deposited in the TSF will continue to consolidate and release water. After ore processing concludes, soil/rock cover materials will be placed progressively inward from the facility perimeter as the tailings surface is able to support construction vehicle traffic. After installation of the TSF cover, consolidation water from the TSF will report to the tailings surface where it will mix with meteoric water that has infiltrated the cover and with runoff water from the cover surface. Run-on water onto the TSF will be limited by use of the operational-phase surface water diversions around the TSF to divert hillslope run-on from the areas above the TSF away from the TSF cover.

In the first 8 years following cessation of mine operations (i.e., from Years 13 to 20), the TSF runoff water will be either evaporated or treated at the WTP that was used during mine operations. The estimated annual average flows to the WTP from the consolidation water mixture during this period are shown in Table 3-8. The monthly TSF runoff and cover seepage flows are shown in Table 3-9. In general, the consolidation water flows have only slight changes month to month as they are not significantly influenced by meteoric events, and, therefore, are not shown in Table 3-9.

**Table 3-8. Annual Average TSF Flows to the Active WTP During Post-Closure  
(assuming 12 years of mine- operations period)**

Mine Year	Post-Mine Operations Year	Annual Average Flow (gpm)				
		Supernatant Dewatering <sup>a</sup>	TSF Runoff <sup>b</sup>	TSF Cover Seepage <sup>b</sup>	Consolidation Water <sup>c</sup>	Total
13	1	25	116	150	228	519
14	2	0	116	150	220	486
15	3	0	116	150	211	477
16	4	0	116	150	204	470
17	5	0	116	150	203	469
18	6	0	116	150	199	465
19	7	0	116	150	193	459
20	8	0	116	150	188	454

Notes:

<sup>a</sup> Supernatant pond water volume is expected to be dewatered over a 3-month period at an average flow rate of approximately 25 gpm (SWWB 2018a).

<sup>b</sup> TSF runoff and cover seepage rates were calculated based on runoff and precipitation rates in the meteoric water balance (SWWB 2018a).

<sup>c</sup> As the tailings density increases, the tailings void ratio decreases, releasing water held within the pore spaces of the tailings deposit forming consolidation water. Tailings consolidation curve data (modified in 2019 from Tierra Group 2015) were used to calculate the release of entrained water during consolidation.

Abbreviations:

gpm = gallon per minute

SWWB = site-wide water balance

TSF = tailings storage facility

WTP = water treatment plant

**Table 3-9. Monthly TSF Runoff and Cover Seepage Flows**

Month	Average Year in gpm		95th PCTL in gpm	
	Runoff <sup>a</sup>	Cover Seepage <sup>a</sup>	Runoff <sup>a</sup>	Cover Seepage <sup>a</sup>
January	0	0	0	0
February	0	5	0	0
March	1	53	0	0
April	190	462	525	549
May	699	518	1,635	549
June	476	453	699	549
July	0	15	0	0
August	0	1	0	0
September	9	93	0	0
October	9	188	24	549
November	0	11	0	0
December	0	0	0	0
Average Flow	116	150	240	183



Month	Average Year in gpm		95th PCTL in gpm	
	Runoff <sup>a</sup>	Cover Seepage <sup>a</sup>	Runoff <sup>a</sup>	Cover Seepage <sup>a</sup>
Annual Volume in MG (ac-ft)	61 (186)	79 (242)	126 (388)	96 (295)

Notes:

<sup>a</sup> TSF runoff and cover seepage rates were calculated based on runoff and precipitation rates in the meteoric water balance (SWWB 2018a).

Abbreviations:

ac-ft = acre feet

MG = million gallons

TSF = tailings storage facility

gpm = gallon per minute

PCTL = percentile

Through the use of water management strategies, such as flow equalization in contact water storage ponds and diversions to prevent portions of runoff from comingling with the consolidation water, the peak monthly flow rate requiring treatment will be reduced from that shown in Table 3-9 so that, after Year 20, a 750-gpm capacity passive treatment system will be used to treat the consolidation waters.

### 3.2.3 Post-Closure RIBs Operation with Yellow Pine Pit Dewatering Water

The RIBs will continue to be operated for the first approximately 2.5 years of the reclamation period to support alluvial groundwater levels and streamflow in lower Meadow Creek while the Hangar Flats pit lake is filling. Water will be pumped from the Yellow Pine pit dewatering system to the RIBs. These flows will be delivered to the active WTP prior to discharge in the RIBs. The peak monthly demand for RIBs infiltration is 700 gpm and occurs in February. In contrast, the peak flow rates from the other sources requiring treatment in the early post-closure period occur in the months of April through June.

### 3.2.4 Post-Closure Fiddle DRSF Toe Seepage

The Fiddle DRSF toe seepage following mine operations will be an annual average flow of 82 gpm and a peak monthly flow of 400 gpm (BC 2018b). This assumes that the 9.2-million-gallon (28.2 acre-feet) contact water storage pond located at the toe of Fiddle DRSF will be utilized post-closure to equalize the spring snowmelt flows from the Fiddle DRSF toe seepage. A diversion channel will continue to divert surface runoff around the contact water storage pond post-closure.

### 3.2.5 Post-Closure Hangar Flats and West End Pit Lake Water

Pit lake water balances were modeled on a monthly time step over 100 years for both Hangar Flats and West End pit lakes (BC 2018b, 2019b). The modeling indicates that, absent active management, Hangar Flats pit will fill in 6 months to 5 years after closure, depending on meteorological conditions. After that, there will be continual outflow anticipated to need treatment before discharge to WOTUS. The maximum monthly flow from the Hangar Flats pit will be 2,350 gpm, and the maximum annual average flow needing treatment will be 1,060 gpm. The proposed treatment system for the Hangar Flats pit lake flows are described in Section 8.1.

Excess water discharging from West End pit will be much less frequent. Modeling predicts that, absent management actions, West End pit lake would discharge to West End Creek during just 5 years out of 100, and only for brief periods each of those years. The maximum monthly and maximum average annual flow rates, which will discharge if pit lake levels are not actively managed through enhanced evaporation or treatment, will be 3,000 gpm and 380 gpm, respectively. The contingency plan to treat discharge from the West End pit lake is described in Section 8.4.

## Section 4

# Treatment System Influent Water Quality

Predicted average dissolved concentrations for the contact water sources, excluding the in-pit surface runoff waters, are provided in the SWWC report (SRK 2018). Values in the SWWC report were used to project water quality for the combined contact water sources during and after mine operations, in terms of flow-weighted-average concentrations, which are presented in this section. Note that the water quality model predictions are based on dissolved phase concentrations from the humidity cell tests. Additional monitoring for total as well as dissolved concentrations will be used to evaluate physical erosion effects during operations and predictions updated accordingly.

Information provided in the SWWC report was all on annual average basis. The design basis for the WTP is based on maximum monthly flows and average concentrations. The mass loading to treatment may be overestimated using this approach, as lower concentrations are likely to occur during the peak flow months, as demonstrated in baseline monitoring on site. Rather, higher than average concentrations will likely occur during lower flow periods. The treatment processes will have the mechanisms to respond to some level of varying concentrations, such as chemical dosing to account for increased influent concentrations.

### 4.1 Mine Construction and Operations Water Quality Summary

The predicted water quality for the combined contact water sources generated during mine operations is shown in Table 4-1. The values presented in Table 4-1 represent the flow-weighted-average concentrations of the groundwater and contact water sources for the mine years shown. Water chemistry information for the contact water generated during the mine construction phase was not available in the SWWC report. It is assumed that this water cannot be discharged untreated and will be required to be either stored for possible use during startup of the ore processing facility, evaporated, or treated and discharged. During the Planned technology confirmation testing of the mobile treatment systems (see Table 2-2), waters emanating from the legacy materials anticipated to be disturbed in construction will be used as source waters for the testing which will reduce the uncertainty of treatment efficacy. Table 4-1 through Table 4-6. list all parameters evaluated by SRK in its geochemical testing and modeling. Only arsenic, antimony, and mercury emerge as significant constituents of concern, so only those constituents are fully evaluated in this Plan with respect to contact water. Midas Gold also anticipates having IPDES permit limits and/or monitoring requirements for other parameters, including temperature, pH, total suspended solids, ammonia, cyanide, copper, cadmium, lead, nickel, selenium, silver, and zinc. Permit limits will be developed, as needed, through the IPDES permit review process based upon Idaho surface water quality standards. Midas Gold may request mixing zones and or variances for specific parameters, where allowable under IPDES regulations and where it would not result in any loss or diminishment of beneficial uses.

Ammonia is not shown in Table 4-1 because the SWWC report (SRK 2018) did not make predictions on its concentration. Literature data from many other open pit mines show contact water ammonia concentrations <0.3 milligrams per liter (mg/L) as Nitrogen (N) (Ferguson and Leask 1988), which is lower than the treatment objective in Table 5-2). Ammonia will be monitored, and the WTP will be modified if needed.

**Table 4-1. Predicted Average Dissolved Concentrations for the Comingled Contact Waters**

Parameter		Units	Anticipated Discharge Limit	Mine Year					
				1	3	5	7	9	11
pH		s.u.	6.5 - 9.0	8.5	8.5	8.2	7.3	7.4	7.3
Alkalinity		mg/L as CaCO <sub>3</sub>	-	78	73	70	81	93	98
Silver	Ag	mg/L	0.0007	4.08E-05	3.94E-05	7.06E-05	5.91E-05	5.31E-05	4.48E-05
Aluminum	Al	mg/L	-	0.36	0.31	0.26	0.17	0.12	0.09
Arsenic	As	mg/L	0.01	0.32	0.31	0.40	0.40	0.26	0.23
Boron	B	mg/L	-	0.03	0.03	0.06	0.05	0.05	0.05
Barium	Ba	mg/L	-	0.040	0.034	0.030	0.039	0.080	0.075
Beryllium	Be	mg/L	-	1.21E-04	1.09E-04	1.59E-04	1.23E-04	9.40E-05	6.93E-05
Calcium	Ca	mg/L	-	14.6	13.9	13.8	19.2	20.1	21.0
Cadmium	Cd	mg/L	3.0E-4	2.76E-05	2.47E-05	3.07E-05	3.06E-05	3.20E-05	3.06E-05
Chloride	Cl	mg/L	-	0.99	0.89	0.83	1.60	1.38	1.15
Cobalt	Co	mg/L	-	1.44E-03	1.31E-03	1.84E-03	1.55E-03	1.22E-03	9.26E-04
Chromium	Cr	mg/L	-	5.93E-04	5.34E-04	8.24E-04	6.84E-04	5.94E-04	4.84E-04
Copper	Cu	mg/L	0.0025	0.0007	6.39E-04	7.86E-04	7.03E-04	6.37E-04	0.001
Fluoride	F	mg/L	-	0.56	0.51	0.47	0.40	0.43	0.38
Iron	Fe	mg/L	-	0.59	0.54	0.47	0.50	0.41	0.34
Mercury	Hg	ng/L	12	15.0	13.8	38.3	36.2	37.1	39.0
Potassium	K	mg/L	-	1.00	1.01	1.28	1.36	1.47	1.60
Magnesium	Mg	mg/L	-	2.35	2.26	2.78	4.67	5.43	7.29
Manganese	Mn	mg/L	-	0.014	0.014	0.016	0.321	0.246	0.203
Molybdenum	Mo	mg/L	-	0.006	0.005	0.006	0.005	0.005	0.004
Sodium	Na	mg/L	-	26.67	23.93	21.38	19.34	23.70	20.00
Nickel	Ni	mg/L	0.024	0.001	0.001	0.002	0.001	0.001	0.001
Phosphorus	P	mg/L	-	0.05	0.047	0.047	0.048	0.052	0.043
Lead	Pb	mg/L	9.00E-4	3.15E-04	2.71E-04	2.47E-04	1.78E-04	1.35E-04	1.16E-04
Antimony	Sb	mg/L	0.0052	0.011	0.010	0.011	0.018	0.021	0.020
Selenium	Se	mg/L	0.005	0.001	0.001	0.001	0.001	0.001	0.001
Sulfate	SO <sub>4</sub>	mg/L	-	25.8	23.3	23.4	29.2	30.7	29.3
Thallium	Tl	mg/L	-	4.39E-05	4.27E-05	9.34E-05	7.16E-05	6.83E-05	6.29E-05
Vanadium	V	mg/L	-	1.68E-03	1.55E-03	2.08E-03	1.61E-03	1.25E-03	9.38E-04

Parameter		Units	Anticipated Discharge Limit	Mine Year					
				1	3	5	7	9	11
Zinc	Zn	mg/L	0.054	0.003	0.002	0.003	0.003	0.004	0.006
Total dissolved solids	TDS	mg/L	-	186	170	162	165	167	161
Nitrate/nitrite	NO <sub>3</sub> + NO <sub>2</sub>	mg/L as N	-	0.25	0.34	1.34	0.97	0.99	0.87

*Abbreviations:*

CaCO<sub>3</sub> = calcium carbonate

mg/L = milligram per liter

N = nitrogen

ng/L = nanogram per liter

s.u. = standard unit

## 4.2 Mine Reclamation and Post-Closure Water Quality Summary

Following mine operations (i.e., during reclamation and post-closure), the following contact water sources are expected to require treatment: TSF supernatant pond water, TSF consolidation waters (a mixture of consolidation water, TSF cover seepage, and TSF surface runoff), Yellow Pine pit dewatering water directed to RIBs, Fiddle DRSF toe seepage, Hangar Flats pit lake overflow, and West End pit lake overflow.

There will be three separate permanent treatment systems utilized during mine reclamation and post-closure. A fourth treatment system may be required to treat the West End pit lake water but will be a temporary or rented system. The WTP utilized during mine operations will treat the TSF supernatant pond water, the TSF consolidation waters until Year 21, the Yellow Pine pit dewatering water for the 2.5 years after cessation of mine operations, and the Hangar Flats pit lake overflow. A passive treatment system will treat the Fiddle DRSF toe seepage. A separate passive treatment system will treat the TSF consolidation water beginning in Year 21. Water quality information for each of these treatment systems during the reclamation and post-closure phases is included in this section.

### 4.2.1 Reclamation and Post-Closure Flows to WTP – Water Quality Design Basis

The water sources that will be sent to the WTP and the period in which they will be sent to the WTP during reclamation and post-closure are listed in Table 4-2. The projected flow-weighted-average water quality to the WTP for various years during reclamation and post-closure periods is shown in Table 4-3. The consolidation water chemistry was one of the sources used to determine the flow-weighted-average concentration, along with the other sources proposed to be treated at the WTP and listed in Table 4-2. Prior to Year 18, the TSF cover is not expected to be completed; therefore, it is assumed the consolidation water mixture from the TSF consists only of the consolidation water and precipitation that falls onto the TSF area during these years. Cover seepage, cover surface runoff, and run-on from adjacent hillsides are not assumed to comingle with the consolidation water until after the cover has been completed (i.e., Year 18).

**Table 4-2. Anticipated Water Sources to be Treated at the WTP During Reclamation and Post-Closure**

<b>Water Source to be Treated</b>	<b>Anticipated Mine Years</b>
TSF supernatant pond water	Year 13
TSF consolidation waters	Years 13 through 20
Yellow Pine pit dewatering water	Years 13 through 15.5
Hangar Flats pit lake overflow	Indefinitely

*Abbreviations:**TSF = tailings storage facility**WTP = water treatment plant*

Table 4-3. Predicted Average Dissolved Concentrations to the WTP During Reclamation and Post-Closure

Parameter		Units	Anticipated Discharge Limit	Mine Year						
				13	17	22	32	42	62	112
pH		s.u.	6.5 - 9.0	8.17	7.63	8.15	8.05	8.02	8.01	8.02
Alkalinity		mg/L as CaCO <sub>3</sub>	-	101	81	53	41	37	36	38
Silver	Ag	mg/L	7.00E-04	5.13E-04	1.26E-05	1.90E-05	1.90E-05	1.90E-05	1.90E-05	1.90E-05
Aluminum	Al	mg/L	-	0.22	0.003	0.003	0.003	0.003	0.003	0.003
Arsenic	As	mg/L	0.01	1.9	1.1	0.10	0.03	0.01	0.01	0.01
Boron	B	mg/L	-	0.038	0.027	0.032	0.028	0.027	0.026	0.027
Barium	Ba	mg/L	-	0.029	1.13E-05	6.20E-06	1.20E-05	2.20E-05	2.80E-05	2.50E-05
Beryllium	Be	mg/L	-	2.57E-04	6.30E-10	1.50E-07	2.10E-07	2.50E-07	2.70E-07	2.20E-07
Calcium	Ca	mg/L	-	118	80	18	11	10	9	10
Cadmium	Cd	mg/L	3.00E-04	4.24E-05	1.83E-05	2.30E-05	2.10E-05	2.00E-05	2.00E-05	2.00E-05
Chloride	Cl	mg/L	-	4.5	3.3	1.6	1.0	0.8	0.8	0.8
Cobalt	Co	mg/L	-	0.0027	0.0003	0.0002	0.0001	0.0001	0.0001	0.0001
Chromium	Cr	mg/L	-	0.0013	2.14E-08	6.90E-06	1.10E-05	1.30E-05	1.30E-05	9.90E-06
Copper	Cu	mg/L	0.0025	0.10	0.06	5.00E-03	1.30E-03	3.60E-04	1.90E-04	1.90E-04
Fluoride	F	mg/L	-	0.53	0.15	0.24	0.25	0.25	0.25	0.25
Iron	Fe	mg/L	-	0.41	0.42	0.29	0.17	0.15	0.14	0.16
Mercury	Hg	ng/L	12	16,000	9,000	760	190	33	5.3	3.8
Potassium	K	mg/L	-	18.5	12.2	1.8	1.0	0.8	0.7	0.7
Magnesium	Mg	mg/L	-	60.5	41.0	6.3	3.0	2.1	2.0	2.0
Manganese	Mn	mg/L	-	0.052	0.160	0.190	0.170	0.140	0.130	0.140
Molybdenum	Mo	mg/L	-	0.023	0.013	0.003	0.002	0.001	0.001	0.001
Sodium	Na	mg/L	-	1,188	752	65	18	5	3	3

Parameter		Units	Anticipated Discharge Limit	Mine Year						
				13	17	22	32	42	62	112
Nickel	Ni	mg/L	0.024	0.007	2.83E-04	3.00E-04	2.50E-04	2.30E-04	2.30E-04	2.30E-04
Phosphorus	P	mg/L	-	0.13	NA	NA	NA	NA	NA	NA
Lead	Pb	mg/L	9.00E-04	2.86E-04	5.61E-08	4.30E-07	6.00E-07	6.70E-07	6.70E-07	5.30E-07
Antimony	Sb	mg/L	0.0052	0.86	0.54	3.40E-05	4.80E-05	5.40E-05	5.60E-05	5.00E-05
Selenium	Se	mg/L	0.005	0.0024	0.0004	0.0008	0.0009	0.0009	0.0009	0.0009
Sulfate	SO <sub>4</sub>	mg/L	-	2546	1619	137	36	9	5	4
Thallium	Tl	mg/L	-	1.14E-04	3.28E-05	3.60E-05	2.90E-05	2.60E-05	2.60E-05	2.70E-05
Vanadium	V	mg/L	-	0.003	1.64E-04	2.30E-04	2.20E-04	2.20E-04	2.10E-04	2.20E-04
Zinc	Zn	mg/L	0.054	0.006	0.002	0.002	0.002	0.001	0.001	0.001
Total dissolved solids	TDS	mg/L	-	3,554	2,269	284	111	66	57	59
Nitrate/nitrite	NO <sub>3</sub> + NO <sub>2</sub>	mg/L as N	-	3.4	2.1	0.2	0.1	0.1	0.0	0.05

*Abbreviations:*

CaCO<sub>3</sub> = calcium carbonate

mg/L = milligram per liter

N = nitrogen

N/A = not applicable

ng/L = nanogram per liter

s.u. = standard unit

## 4.2.2 TSF Consolidation Waters Passive Treatment System – Water Quality Design Basis

The passive treatment system designed to treat the TSF consolidation waters will come online in Year 21. The quality of the TSF consolidation water, cover seepage, runoff, and run-on water mixture was predicted in the SWWC report (SRK 2018).; However, the water chemistry used as the design basis for the WTP is different than that shown in the SWWC report because of the prevention of run-on flows onto the TSF and the reduction of runoff flows (estimated to be at least 50 percent) through the addition of diversions that will prevent a portion of the runoff water from comingling with the consolidation waters. Taking into consideration these changes, the water chemistry of the consolidation water mixture to the passive treatment system was estimated and tabulated in Table 4-4.

Table 4-4. Predicted Average Dissolved Concentrations for the TSF Consolidation Water Mixture

Parameter		Units	Anticipated Discharge Limit	Predicted Average Dissolved Concentration by Mine Year <sup>a</sup>			
				22	27	32	42
pH		s.u.	6.5 - 9.0	7.62	7.55	7.52	7.49
Alkalinity		mg/L as CaCO <sub>3</sub>	-	63	31	19	4
Silver	Ag	mg/L	7.00E-04	<0.006	<0.006	<0.006	<0.006
Aluminum	Al	mg/L	-	<0.05	<0.05	<0.05	<0.05
Arsenic	As	mg/L	0.01	2.180	0.990	0.578	0.035
Boron	B	mg/L	-	<0.2	<0.2	<0.2	<0.2
Barium	Ba	mg/L	-	<0.02	<0.02	<0.02	<0.02
Beryllium	Be	mg/L	-	<0.002	<0.002	<0.002	<0.002
Calcium	Ca	mg/L	-	144	68.4	42.0	6.83
Cadmium	Cd	mg/L	3.00E-04	<0.0002	<0.0002	<0.0002	<0.0002
Chloride	Cl	mg/L	-	3.03	1.37	0.79	0.03
Cobalt	Co	mg/L	-	<0.01	<0.01	<0.01	<0.01
Chromium	Cr	mg/L	-	<0.005	<0.005	<0.005	<0.005
Copper	Cu	mg/L	0.0025	0.126	0.056	0.032	0.00035
Fluoride	F	mg/L	-	0.008	0.012	0.013	0.013
Iron	Fe	mg/L	-	0.0583	0.0300	0.0200	0.0063
Mercury	Hg	ng/L	12	19,000	8,500	4,800	40
Potassium	K	mg/L	-	23.4	10.6	6.17	0.33
Magnesium	Mg	mg/L	-	76.7	34.4	19.8	0.59
Manganese	Mn	mg/L	-	0.0565	0.0253	0.015	0.00034
Molybdenum	Mo	mg/L	-	0.023	0.010	0.006	3.81E-05
Sodium	Na	mg/L	-	1,531	685	392	8.0
Nickel	Ni	mg/L	0.024	<0.01	<0.01	<0.01	<0.01

Parameter		Units	Anticipated Discharge Limit	Predicted Average Dissolved Concentration by Mine Year <sup>a</sup>			
				22	27	32	42
Phosphorus	P	mg/L	-	<0.5	<0.5	<0.5	<0.5
Lead	Pb	mg/L	9.00E-04	<0.0007	<0.0007	<0.0007	<0.0007
Antimony	Sb	mg/L	0.0052	1.11	0.502	0.29	0.011
Selenium	Se	mg/L	0.005	<0.002	<0.002	<0.002	<0.002
Sulfate	SO <sub>4</sub>	mg/L	-	3,316	1,494	863	33
Thallium	Tl	mg/L	-	<0.002	<0.002	<0.002	<0.002
Vanadium	V	mg/L	-	<0.01	<0.01	<0.01	<0.01
Zinc	Zn	mg/L	0.054	<0.01	<0.01	<0.01	<0.01
Total dissolved solids	TDS	mg/L	-	4,500	2,030	1,175	50
Nitrate/nitrite	NO <sub>3</sub> + NO <sub>2</sub>	mg/L as N	-	4.34	1.96	1.14	0.053

Notes:

<sup>a</sup> Concentration values shown were calculated after excluding run-on and 50 percent of the runoff.

Abbreviations:

CaCO<sub>3</sub> = calcium carbonate

mg/L = milligram per liter

N = nitrogen

ng/L = nanogram per liter

s.u. = standard unit

TSF = tailings storage facility

### 4.2.3 Fiddle DRSF Toe Seepage Passive Treatment System – Water Quality Design Basis

The predicted Fiddle DRSF toe seepage water chemistry during reclamation and post-closure is shown in Table 4-5. During post-closure, the Fiddle DRSF toe seepage will be treated independently of the other post-closure flow streams. Therefore, Table 4-5 will serve as the design basis for the post-closure Fiddle DRSF toe seepage treatment system.

Table 4-5. Predicted Average Dissolved Concentrations from the Fiddle DRSF Toe Seepage During Reclamation and Post-Closure

Parameter	Units	Anticipated Discharge Limit	Predicted Concentration
pH	s.u.	6.5 - 9.0	8.01
Alkalinity	mg/L as CaCO <sub>3</sub>	-	37.2
Silver	Ag	7.00E-04	7.21E-05
Aluminum	Al	mg/L	0.003
Arsenic	As	mg/L	0.65
Boron	B	mg/L	0.13
Barium	Ba	mg/L	1.60E-06
Beryllium	Be	mg/L	9.21E-08
Calcium	Ca	mg/L	7.6
Cadmium	Cd	mg/L	4.00E-05

Parameter		Units	Anticipated Discharge Limit	Predicted Concentration
Chloride	Cl	mg/L	-	0.41
Cobalt	Co	mg/L	-	4.40E-04
Chromium	Cr	mg/L	-	4.00E-06
Copper	Cu	mg/L	0.0025	4.10E-04
Fluoride	F	mg/L	-	0.22
Iron	Fe	mg/L	-	0.046
Mercury	Hg	ng/L	12	120
Potassium	K	mg/L	-	2.33
Magnesium	Mg	mg/L	-	4.18
Manganese	Mn	mg/L	-	0.011
Molybdenum	Mo	mg/L	-	2.30E-04
Sodium	Na	mg/L	-	4.06
Nickel	Ni	mg/L	0.024	1.70E-04
Phosphorus	P	mg/L	-	0.040
Lead	Pb	mg/L	9.00E-04	1.801E-06
Antimony	Sb	mg/L	0.0052	1.70E-04
Selenium	Se	mg/L	0.005	0.001
Sulfate	SO <sub>4</sub>	mg/L	-	14.6
Thallium	Tl	mg/L	-	2.00E-04
Vanadium	V	mg/L	-	3.60E-04
Zinc	Zn	mg/L	0.054	0.004
Total dissolved solids	TDS	mg/L	-	71.6
Nitrate/nitrite	NO <sub>3</sub> + NO <sub>2</sub>	mg/L as N	-	0.06

*Abbreviations:*

CaCO<sub>3</sub> = calcium carbonate

DRSF = development rock storage facility

mg/L = milligram per liter

N = nitrogen

ng/L = nanogram per liter

s.u. = standard unit

#### 4.2.4 West End Pit Lake Overflow Water – Water Quality Design Basis

Table 4-6 shows the projected water quality for the West End pit lake. The water level in the West End pit lake will be monitored and if the pit lake is expected to produce overflow during the subsequent year, the pit lake water in the pit lake will be treated with using a temporary treatment system prior to discharge.

Table 4-6. Predicted Average Dissolved Concentrations of the West End Pit Lake

Parameter		Units	Anticipated Discharge Limit	Predicted Average Dissolved Concentration by Mine Year							
				13	14	17	22	32	42	62	112
pH		s.u.	6.5 - 9.0	8.44	8.44	8.42	8.42	8.42	8.41	8.41	8.41
Alkalinity		mg/L as CaCO <sub>3</sub>	-	102	103	99	98	98	96	95	96
Silver	Ag	mg/L	7.00E-04	2.6E-04	2.8E-04	2.2E-04	2.2E-04	2.3E-04	2.0E-04	1.8E-04	2.0E-04
Aluminum	Al	mg/L	-	0.0037	0.0037	0.0036	0.0036	0.0036	0.0036	0.0035	0.0035
Arsenic	As	mg/L	0.01	0.25	0.27	0.21	0.20	0.20	0.17	0.15	0.16
Boron	B	mg/L	-	0.145	0.15	0.128	0.126	0.128	0.116	0.107	0.115
Barium	Ba	mg/L	-	1.8E-06	1.7E-06	2.0E-06	2.1E-06	2.1E-06	2.3E-06	2.6E-06	2.4E-06
Beryllium	Be	mg/L	-	2.9E-06	3.6E-06	1.9E-06	1.8E-06	1.8E-06	1.4E-06	1.2E-06	1.5E-06
Calcium	Ca	mg/L	-	15.8	15.5	16.6	16.7	16.7	17.2	17.6	17.2
Cadmium	Cd	mg/L	3.00E-04	1.4E-04	1.5E-04	1.2E-04	1.2E-04	1.2E-04	1.1E-04	1.0E-04	1.0E-04
Chloride	Cl	mg/L	-	0.65	0.69	0.60	0.61	0.61	0.57	0.54	0.57
Cobalt	Co	mg/L	-	5E-05	5E-05	4E-05	4E-05	3E-05	3E-05	3E-05	3E-05
Chromium	Cr	mg/L	-	4E-05	4E-05	3E-05	3E-05	3E-05	2E-05	2E-05	2E-05
Copper	Cu	mg/L	0.0025	0.0010	0.0010	9.2E-04	9.0E-04	8.9E-04	8.6E-04	8.5E-04	9.6E-04
Fluoride	F	mg/L	-	0.21	0.21	0.21	0.21	0.21	0.21	0.21	0.21
Iron	Fe	mg/L	-	3.8E-04	3.4E-04	7.0E-04	9.0E-04	9.0E-04	0.0021	0.0041	0.0026
Mercury	Hg	ng/L	12	400	430	350	350	360	330	300	320
Potassium	K	mg/L	-	3.14	3.30	2.74	2.67	2.68	2.46	2.25	2.41
Magnesium	Mg	mg/L	-	17.4	18.1	15.5	15.1	14.9	13.9	13.0	13.6
Manganese	Mn	mg/L	-	0.006	0.0057	0.005	0.005	0.005	0.004	0.004	0.004
Molybdenum	Mo	mg/L	-	0.002	0.0016	0.001	0.001	0.001	0.001	0.001	0.001
Sodium	Na	mg/L	-	2.2	2.3	2.0	2.0	2.0	1.8	1.7	1.8
Nickel	Ni	mg/L	0.024	3.5E-04	3.6E-04	3.1E-04	3.0E-04	2.9E-04	2.7E-04	2.5E-04	2.6E-04

Parameter		Units	Anticipated Discharge Limit	Predicted Average Dissolved Concentration by Mine Year							
				13	14	17	22	32	42	62	112
Lead	Pb	mg/L	9.0E-04	5.0E-05	6.0E-05	3.0E-05	2.0E-05	2.0E-05	2.0E-05	1.0E-05	2.0E-05
Antimony	Sb	mg/L	0.0052	0.016	0.020	7.0E-03	5.1E-03	4.6E-03	1.8E-03	9.1E-04	1.4E-03
Selenium	Se	mg/L	0.005	6.5E-04	6.5E-04	6.5E-04	6.5E-04	6.5E-04	6.6E-04	6.6E-04	6.6E-04
Sulfate	SO <sub>4</sub>	mg/L	-	18	19.4	15	14	13	11	9	11
Thallium	Tl	mg/L	-	1.3E-05	1.3E-05	1.3E-05	1.3E-05	1.3E-05	1.3E-05	1.3E-05	1.3E-05
Vanadium	V	mg/L	-	1.3E-04	1.3E-04	1.3E-04	1.3E-04	1.3E-04	1.3E-04	1.3E-04	1.3E-04
Zinc	Zn	mg/L	0.054	0.014	0.015	0.011	0.011	0.010	0.009	0.007	0.008
Total dissolved solids	TDS	mg/L	-	160	163	151	149	149	144	140	143
Nitrate/ nitrite	NO <sub>3</sub> + NO <sub>2</sub>	mg/L as N	-	0.83	0.04	0.04	0.04	0.04	0.04	0.04	0.04

*Abbreviations:*

*CaCO<sub>3</sub> = calcium carbonate*

*mg/L = milligram per liter*

*N = nitrogen*

*ng/L = nanogram per liter*

*s.u. = standard unit*

## Section 5

# Treatment Objectives

The relevant numeric criteria in each set of potentially applicable water quality standards are listed in Table 5-1. Narrative standards<sup>7</sup>, although not shown, may also be applicable. Using the numeric criteria for the design bases is a conservative assumption because there is a possibility that mixing zones may be granted for some parameters and/or that the presence of elevated ambient levels of some parameters may be justification for allowing discharge with some constituents above the criteria but below ambient concentrations or loads. Discharge permit limits may not be set using water quality standards as end of pipe criteria for some parameters; permit limits will be determined during the IPDES permit process.

Using this information, the WTP treatment objectives presented in Table 5-2 were developed. The treatment objectives are the lowest of the Idaho numeric surface water criteria and new source performance standards shown in Table 5-1. Comparison of these water treatment objectives with the WTP influent concentrations during mine operations (Table 4-1) shows that the WTP must remove arsenic, antimony, and mercury to achieve the treatment objectives. In addition, copper may be slightly higher than the treatment objective in Year 1.

The effluent targets provided in Table 5-2 for arsenic, antimony, and mercury anticipate IPDES permit limits based upon the most stringent applicable Idaho water quality criteria. The targets are monthly average values, with daily maximum values potentially somewhat higher, but still well below ambient receiving water conditions for arsenic and antimony, thus always contributing to a net improvement in surface water quality during effluent discharge (see Section 9 for discussion of anticipated in-stream water quality). Midas Gold continues to work toward an IPDES permit with IDEQ and the EPA, which could result in final permit limits somewhat different from the values in Table 5-2, but which would still represent compliance with Idaho water quality standards and the Clean Water Act via the IPDES process.

**Table 5-1. Applicable Water Quality Criteria**

Analyte	Units	Idaho Numeric Surface Water Human Health Criteria		Idaho Numeric Surface Water Criteria for Cold Water Biota <sup>a,b</sup>		New Source Performance Standards (40 CFR 440.104)		General/ Other Criteria
		Drinking Water and Fish Consumption	Fish Consumption Only	CMC (acute)	CCC (chronic)	Daily Maximum	30-Day Average	
pH	s.u.	-	-	-	-	6-9	6-9	6.5-9.0
Temperature	°C	-	-	-	-	-	-	< 13, < 9 <sup>c</sup>
Total Suspended Solids	mg/L	-	-	-	-	30	20	-

<sup>7</sup> An example of a narrative standard: "Oxygen-Demanding Materials. Surface waters of the state shall be free from oxygen-demanding materials in concentrations that would result in an anaerobic water condition." Idaho Administrative Procedures Act (IDAPA) 58.01.02.200.07.

Analyte	Units	Idaho Numeric Surface Water Human Health Criteria		Idaho Numeric Surface Water Criteria for Cold Water Biota <sup>a,b</sup>		New Source Performance Standards (40 CFR 440.104)		General/ Other Criteria
		Drinking Water and Fish Consumption	Fish Consumption Only	CMC (acute)	CCC (chronic)	Daily Maximum	30-Day Average	
Ammonia <sup>d</sup>	mg/L as NH <sub>3</sub>	-	-	4.64	2.1	-	-	-
Antimony	mg/L	0.0052	0.190	-	-	-	-	-
Arsenic	mg/L	0.010	0.010	0.34	0.15	-	-	-
Cadmium <sup>b</sup>	mg/L	-	-	0.00062	0.00033	0.1	0.05	-
Chlorine, residual	mg/L	-	-	0.019	0.011	-	-	-
Chromium (III) <sup>b</sup>	mg/L	-	-	0.269	0.035	-	-	-
Chromium (VI) <sup>b</sup>	mg/L	-	-	0.0157	0.0106	-	-	-
Copper <sup>f</sup>	mg/L	-	-	0.004 <sup>g</sup>	0.0025 <sup>g</sup>	0.3	0.15	-
Cyanide, total	mg/L	0.0039	0.14	0.022	0.0052	-	-	-
Cyanide, weak acid dissociable	mg/L	-	-	0.022	0.0052	-	-	-
Lead <sup>b</sup>	mg/L	-	-	0.024	0.0009	0.6	0.3	-
Mercury <sup>g</sup>	ng/L	-	-	2,100	12	2,000	1,000	-
Nickel <sup>b</sup>	mg/L	0.058	0.10	0.216	0.024	-	-	-
Selenium, total	mg/L	0.029	0.25	0.02	0.005	-	-	-
Silver <sup>b</sup>	mg/L	-	-	0.0007	-	-	-	-
Zinc <sup>b</sup>	mg/L	-	-	0.054	0.054	1.5	0.75	-

## Notes:

<sup>a</sup> Source: Idaho Administrative Procedures Act (IDAPA) 58.01.02 Water Quality Standards for Surface Water (IDAPA 2017).

<sup>b</sup> The criteria for these metals are hardness-dependent. The values listed are based on East Fork of the South Fork of the Salmon River (EFSFSR) hardness of 40 mg/L as CaCO<sub>3</sub> (calcium carbonate) (5th percentile of driest 4 months at YP-SR-10 for baseline period (April 2012 to May 2019), calculated using the sheets found at <http://www.deq.idaho.gov/water-quality/surface-water/water-quality-criteria/>.

<sup>c</sup> The Project site is in the designated area in which bull trout temperature criteria are applicable. Per IDAPA 58.01.02.250.02.g., during June, July, and August, the effluent shall not exceed 13 degrees Celsius (13 °C) and shall not exceed 9 °C in September and October.

<sup>d</sup> The ammonia criteria are pH- and temperature-dependent. The values listed are based on pH 8.1 SU and temperature 13.6 °C (95th percentile at YP-SR-10 for baseline period (April 2012 to May 2019), calculated using the sheets found at <http://www.deq.idaho.gov/water-quality/surface-water/water-quality-criteria/>.

<sup>f</sup> Copper criteria are determined using the Biotic Ligand Model. Idaho Department of Environmental Quality (IDEQ) provides guidance for estimating criteria for waters without sufficient input data for the model (IDEQ 2017 Implementation Guidance for the Idaho Copper Criteria for Aquatic Life Using the Biotic Ligand Model, <http://www.deq.idaho.gov/media/60180619/58-0102-1502-implementation-guidance-copper-criteria-0817.pdf>). Values shown here are based upon values for 3rd order streams and the Salmon basin in Table 2 of that guidance and agree closely with preliminary model calculations made with limited data from the Project site.

<sup>g</sup> The EPA disapproved the removal of water column criteria for total recoverable mercury for the protection of aquatic life detailed in Rule Docket No. 58-0102-0302. As noted in section 210.01 of the water quality standards, the state's 2004 aquatic life criteria remain in effect for Clean Water Act purposes. Idaho also has a human health (fish consumption only) fish-tissue methyl mercury criteria of 0.3 mg/kg; this standard was not included in the table because it cannot be directly related to a water treatment target at this time.

**Abbreviations:**

°C = degree Celsius

CCC = criterion continuous concentration

CFR = code of federal regulations

CMC = criterion maximum concentration

mg/kg = milligram per kilogram

mg/L = milligram per liter

ng/L = nanogram per liter

NH<sub>3</sub> = ammonia

s.u. = standard unit

**Table 5-2. WTP Treatment Objectives**

Analyte	Units	Treatment Objective
pH	s.u.	6.5 - 9.0
Ammonia	mg/L as N	2.1
Antimony	mg/L	0.0052
Arsenic	mg/L	0.01
Cadmium	mg/L	0.00033
Chromium(III)	mg/L	0.035
Chromium(VI)	mg/L	0.0106
Copper	mg/L	0.0025
Cyanide, total	mg/L	0.0052
Lead	mg/L	0.0009
Mercury	ng/L	12
Nickel	mg/L	0.024
Selenium	mg/L	0.005
Silver	mg/L	0.0007
Zinc	mg/L	0.054

**Abbreviations:**

mg/L = milligram per liter

N = Nitrogen

ng/L = nanogram per liter

s.u. = standard unit

WTP = water treatment plant

## Section 6

# Identification and Screening of Treatment Technologies

A wide range of water treatment technologies were considered for the SGP. The technologies were screened for their ability to achieve the treatment objectives, based on data from similar applications, and effective technologies were used to assemble treatment processes described in Sections 7 and 8.

New treatment technologies applicable to the SGP may be developed in the future. Midas Gold will keep abreast of new developments in water treatment technologies throughout the mine life and modify this Plan through adaptive management if a new, more appropriate treatment technology emerges.

## 6.1 Evaporation

Evaporation of mine water naturally occurs in open ponds and can be enhanced using mechanical evaporators. Mechanical evaporators increase the rate of evaporation by lifting water droplets with large surface areas into the air. They will be installed at the TSF and possibly elsewhere at the SGP to evaporate water during favorable months and reduce the volume that must be treated. However, because of the large volume of water that would have to be stored during half the year when there is little evaporation, evaporation was rejected as a stand-alone treatment technology for the operations period. However, evaporators will be used in conjunction with other treatment technologies to the extent feasible to reduce water volume. It should be noted that the calculations used for design flow development do not account for the potential reductions in contact water volumes discharged from the storage ponds resulting from the use of enhanced evaporation during storage. Therefore, the use of enhanced evaporation would reduce the volumes assumed in this Plan.

## 6.2 Iron Coprecipitation

Iron coprecipitation entails the addition of ferric sulfate or ferric chloride to the water, and pH adjustment to precipitate iron oxyhydroxides (ferrihydrite). At circum-neutral pH, the precipitated iron oxyhydroxide particles have a positive surface charge, and anionic contaminants such as arsenic and antimony are removed. The removal mechanism is a combination of adsorption, occlusion, and other processes collectively called coprecipitation. Cationic contaminants, such as mercury, are coprecipitated more effectively at higher pH, where the iron oxyhydroxide particles have a negative surface charge.

Iron coprecipitation will consist of chemical feed and mixing systems followed by solid-liquid separation devices such as a clarifier. Typically, the clarifier sludge is thickened and then dewatered in a centrifuge or filter press, and the dewatered cake is sent to a landfill. At the SGP, the clarifier sludge will likely be pumped to the TSF. Ferric sulfate will be used rather than ferric chloride to prevent chloride accumulation in the ore processing circuit because ferric chloride solution can contain mercury. Temporary treatment systems will be used during mine construction and the initial years of operations, when flows are low.

Arsenic can be present in natural waters in two species: As(III) and As(V). Iron coprecipitation is much more effective on As(V). Therefore, an iron coprecipitation system for arsenic removal would include an

oxidation step to convert As(III) to As(V). The peak influent arsenic concentration shown in Table 4-1 is 0.40 mg/L, and the treatment objective shown in Table 5-2 is 0.010 mg/L. Iron coprecipitation is routinely used to remove arsenic and, with a high enough iron dose, the arsenic concentration can be reduced to 0.010 mg/L (Twidwell 2011). Organo-arsenic, which might be more difficult to remove, is not expected as there is limited organics in the soil to promote the biological activity that would be needed to form it.

The peak influent antimony concentration shown in Table 4-1 is 0.021 mg/L, and the treatment objective shown in Table 5-2 is 0.0052 mg/L, so 75 percent removal is needed. Data for iron coprecipitation show 90 percent removal of antimony in Sb(V) species and higher removal of Sb(III) species (Inoue and Munemori 1980); therefore, iron coprecipitation will achieve the antimony treatment objective.

The peak influent mercury concentration shown in Table 4-1 is 0.000039 mg/L (39 nanograms per liter [ng/L]), and the treatment objective shown in Table 5-2 is 0.000012 mg/L (12 ng/L). BC has not found literature data indicating that iron coprecipitation could achieve this treatment objective in a single stage if the mercury is dissolved. Available data show treated concentrations in the range of 0.048 mg/L (48,000 ng/L), although at a higher initial concentration (Inoue and Munemori 1979). However, if the mercury is associated with particles, then iron coprecipitation including filtration will be able to achieve this treatment objective (Negri et al. 2011). Technology confirmation tests using representative water from the Project site will show if the mercury form is soluble and whether iron coprecipitation can meet the mercury treatment objective without additional precipitation steps.

To be able to discharge the clarifier sludge to the TSF, the sludge will need to pass a TCLP test to confirm that the sludge waste is not characteristically hazardous. From review of the SGP water chemistry and TCLP maximum leachable concentrations, arsenic is the only constituent that could potentially become concentrated to the point that the sludge would be classified as a hazardous waste. BC's experience, as well as literature review, indicates that arsenic from iron coprecipitation sludges is not leachable in the TCLP. Even if it were, the clarifier sludge solids concentration could be maintained low enough that the stream would not become a hazardous waste. Therefore, for the purposes of this Plan it is assumed that the clarifier sludge produced from iron coprecipitation will be disposed in the TSF. Technology confirmation tests will be used to verify this assumption.

Iron coprecipitation was selected as a component of the WTP to remove arsenic and antimony, as discussed in Section 7.

### 6.3 Sulfide Precipitation

Metal sulfides have low solubility; therefore, sulfide can be added to precipitate inorganic contaminants to very low levels. Organic sulfide precipitants and inorganic sulfide compounds, such as sodium hydrogen sulfide and calcium polysulfide, are widely used to remove cationic metals such as mercury if present in dissolved form; if in particles, physical methods would remove the mercury. Similar to iron coprecipitation, the metals are transferred to a sludge.

In particular, mercury sulfide compounds are very insoluble. Single-digit ng/L levels of mercury are attainable (Higgins et al. 2013) using organic sulfide precipitants. The precipitant would be added in a conventional coagulation-flocculation-sedimentation system similar to an iron coprecipitation system, and dissolved mercury would be removed onto solids that would be conveyed to the TSF.

Arsenic and antimony are less easily removed using sulfide precipitation. To make arsenic and antimony sulfides, low pH (approximately pH 3) and high temperature would be required, which would make this process less attractive than iron coprecipitation at the SGP. There would be health and safety issues

regarding the use of hydrogen sulfide at low pH, and the cost of heating the water before treatment and cooling it before discharge would be excessive.

Based on this analysis, sulfide precipitation was selected for use as a contingency to remove dissolved mercury (and for which high temperatures are not required as for arsenic or antimony), if iron coprecipitation alone cannot achieve the mercury treatment objective, as discussed in Section 7.

## 6.4 Adsorption

Industrial materials are available that remove dissolved components from solution through adsorption. These materials are single use, so they must be disposed and replaced once they become saturated (i.e., exhausted). Adsorption is conducted in packed columns that are typically operated in a lead-lag configuration. Adsorption is widely used to remove arsenic from drinking water sources; however, the arsenic concentrations are typically an order of magnitude lower than the concentrations presented in Section 4. The consequence of high arsenic concentrations in the source water would be rapid exhaustion of the media. Therefore, adsorption by itself would not be economically competitive for multi-year treatment due to excessive adsorbent consumption and change-out.

Adsorption could potentially be used to remove mercury downstream of iron coprecipitation. Nucon (not dated) reported its MERSORB sulfur-impregnated activated carbon achieved less than 10 ng/L mercury in effluent when treating a stream containing 300,000 ng/L mercury. Argonne National Laboratory reported isotherm data showing adsorption of mercury down to <0.5 ng/L (Negri et al. 2011). These tests, which used water with chemistry different than expected at the Project site, showed that mercury concentrations can be lowered to meet the 12 ng/L target. However, there is significant uncertainty as to how well these technologies will perform with the water treatment volumes, water chemistries, and flow rates expected at the Project site. Results from the previously mentioned studies are occurring under much more ideal conditions for sorption than would occur in this WTP; therefore, these technologies remain unproven as to whether they can be used to meet the mercury treatment objective for the SGP.

Although it would be technically feasible, adsorption was not selected for the WTP because adsorbent would have to be transported to the WTP and spent adsorbent would have to be transported to a landfill. Sulfide precipitation is preferable because the residuals could be conveyed to the TSF.

## 6.5 Ion Exchange

Ion exchange is widely used for water softening to remove hardness, but it can also be used to remove trace contaminants. Like adsorption, it is conducted in packed beds. The resins used for ion exchange are more expensive than adsorption media, so ion exchange beds are regenerated onsite using a brine solution, which is commonly a chloride compound. From discussions with ion exchange resin providers, at least two different resin types would be required to remove the contaminants to achieve the treatment objectives, resulting in a complex system.

Ion exchange would produce a residual—waste brine—that cannot be sent to the TSF. The arsenic concentration of the waste brine would be so high that it would likely be classified as a hazardous waste. Therefore, it would have to be transported off site for disposal. It would also add hundreds of tons of chloride to the ore processing circuit. The amount of brine requiring disposal, which is a function of the frequency of regeneration, would depend on the total amount of ions that would be removed, not just mercury and arsenic; antimony, phosphate, and potentially manganese and sulfate could also impact it.

Because the waste brine would have to be hauled off site for disposal, ion exchange was not selected for the WTP.

## 6.6 Membrane Treatment

Reverse osmosis (RO) and nanofiltration (NF) systems purify water by passing it through a semi-permeable membrane under pressure. RO and NF differ from each other by the size of ions that each can remove. RO membranes have a smaller pore size than NF and, therefore, are more effective in removing smaller ions. Arsenic, mercury, and other impurities are too large to pass through either RO or NF membranes, and are concentrated by a factor of approximately 4 to 10. At the SGP, the concentrate could potentially be sent directly to the TSF during mine operations because the membranes would not increase the arsenic concentration enough to generate a hazardous waste. The RO product water, called permeate, would contain so few ions that it would have to be supplemented with hardness and alkalinity before discharging to surface water.

If the concentrate were sent to the TSF, approximately 14 tons of chloride would be added to the ore processing circuit over 9 years. This mass would increase the ore processing circuit chloride by less than 1 mg/L, which would be insignificant relative to concentrations that will already be present in the TSF.

Meeting the treatment objectives requires a minimum 97.5 percent removal of arsenic (0.40 mg/L to less than 0.010 mg/L). A single-pass membrane system can achieve about 90 to 95 percent removal of arsenic (Sato et al. 2002), so a two-pass system would be needed. Data for antimony are not available but, given the size of antimony ions and the fact that only 75 percent removal is needed, a single-pass system would be sufficient. For dissolved mercury, at least 70 percent removal is required (39 ng/L to 12 ng/L). RO was shown to reduce mercury from a landfill leachate from 196 ng/L to 3.7 ng/L (ROCHEM 2019), which is 98 percent removal. Argonne National Laboratory showed RO reduced mercury in a wastewater from 6.3 ng/L to as low as 1.15 ng/L (Negri et al. 2011).

Therefore, a two-pass membrane system could meet treatment objectives during mine operations. However, when the TSF is no longer available to receive the concentrate, additional equipment would be needed to convert arsenic and other constituents into a form that can be transported off site for disposal. Because the intent of the WTP is to treat water during reclamation as well as during mine operations, membrane treatment was not selected as a principal treatment technology for the WTP.

Temporary membrane systems might be used during the initial years of mine operations, when flows are low, or in areas of the Project site that are distant from the WTP. The TSF will be available to receive residuals beginning Year 1. Before that, mobile equipment would be needed to treat the RO concentrate. Residuals from the RO concentrate treatment system would be dewatered and disposed off site.

## 6.7 Biochemical Reactor/Wetlands

Some trace contaminants can be removed from water by biological treatment. For many constituents, including arsenic and mercury, the removal mechanism is precipitation with sulfide, which is formed by anaerobic biological reduction of sulfate (Jackson et al. 2013). Carbonate and hydroxide precipitation also occur (Butler et al. 2010). Biochemical reactors (BCRs) have also been shown to remove antimony (Janin et al. 2015). Significant removal of arsenic and antimony has been documented across the existing Keyway Marsh (HDR Engineering, Inc. [HDR] 2017), and an engineered system would do as well or better. It is unclear whether BCRs remove methylmercury or create it, so methylmercury would need to be monitored.

There are several BCRs in use in the mining industry, primarily for passive treatment of small flows. A smaller number of active WTPs include BCRs for treating larger flows. BCRs have been built in a variety of configurations, including subsurface flow and free-water surface wetlands. An anaerobic zone is necessary for sulfate reduction, but there must also be an aerobic wetland or reactor to oxidize residual

sulfide, which is toxic, before discharge. A BCR effluent can also exceed water quality standards for sulfides, biochemical oxygen demand, and nutrients. BCRs require a startup period to develop the sulfate reducing bacterial population, and low water temperature can extend this startup period, which results in large systems to treat cold flows. Because the BCR and wetlands accumulate the contaminants removed from the water, they must eventually either be excavated and the contents transferred to a landfill or be closed in place.

The BCR is a lined, earthen basin filled with carbonaceous media that serves as electron donor and nutrient supply to support the biological reduction of sulfate, metals, and metalloid oxyanions. Common media used in anaerobic BCRs include sand, hay, straw, wood chips, sawdust, manure, and limestone. This media requires periodic replacement to maintain treatment efficacy.

A BCR was selected for treating smaller flows during post-closure and vertical flow (VF) wetlands were selected for aerobic polishing of BCR effluent. The VF wetland will remove excess sulfide, biochemical oxygen demand, and nutrients including ammonia, if present.

Treating the entire flow during mine operations using BCRs and wetlands would be infeasible due to the large area required. However, passive treatment with BCRs and wetlands is anticipated to be phased in during post-closure, when the flows are expected to be lower, and after pilot testing is accomplished during operations. The pilot BCR/wetland system will be monitored for methylmercury.

## 6.8 Screening Summary

Screening of the water treatment technologies considered for the SGP is summarized in Table 6-1.

**Table 6-1. Screening Summary for WTP Technology**

Technology	Retained	Comments
Evaporation	Not as principal technology	Will be used to reduce water volume but not to evaporate all water.
Iron coprecipitation	Yes	Achieves arsenic and antimony treatment objectives. Uncertainty as to whether mercury treatment objective can be achieved by iron coprecipitation alone.
Sulfide precipitation	Yes, as a contingency	Will be used if dissolved mercury remains after iron coprecipitation. Will not be used for arsenic and antimony removal due to temperature and pH issues.
Adsorption	No	Could be used to remove mercury after iron coprecipitation, but less attractive than sulfide precipitation.
Ion exchange	No	Brine could not be sent to TSF because it would be a hazardous waste.
Membrane treatment	Not as principal technology	Two-pass system would achieve treatment objectives, so temporary membrane system could be used during initial years before WTP is constructed; post-closure brine handling requirements make membrane treatment undesirable as a long-term solution.
BCRs/wetlands	No, during mine operations or reclamation; Yes, for post-closure	Excessive land requirement during mine operations and reclamation.

*Abbreviations:*

BCR = biochemical reactor

TSF = tailings storage facility

WTP = water treatment plant

## Section 7

# Treatment During Construction and Operations

Technologies retained after the initial screening described in Section 6 were assembled into a WTP process for use during operations in Years 4 through 12. Prior to Year 4 during construction and early operations, temporary treatment systems will be applied as described below. Treatment during reclamation and post-closure is described in Section 8.

### 7.1 Process Description

Water will be stored in lined storage ponds for flow equalization and pumped to the WTP. The WTP location is shown in Figure 7-1. The process flow diagram of the proposed WTP is shown in Figure 7-2. The WTP will use iron coprecipitation. If dissolved mercury is present above the treatment objective with iron coprecipitation alone, sulfide precipitation may also be used. Residuals will be conveyed to the TSF. The treatment process will consist of the following:

- Influent blending tanks to provide additional storage during operational downtime and WTP upsets and to allow for water to be recycled back to the WTP during startup of the facility.
- Oxidation using sodium hypochlorite to convert all arsenic to As(V). This step might not be needed, but it was included because the relative amounts of As(III) and As(V) in future contact water are unknown. Sodium hypochlorite will also oxidize ammonia, if present.
- Iron addition to coprecipitate arsenic and antimony. Lime may also be needed in this step, depending on the decrease in pH with iron addition. Approximately 1 ton per day of hydrated lime would be needed during the peak month.
- Clarification to separate settleable solids. The clarifier will be operated to produce an underflow that is not a hazardous waste.
- Mercury precipitation using organic sulfide precipitant, if needed to remove additional mercury after iron coprecipitation. An iron coagulant and a flocculant would also be added to enhance solid/liquid separation, which would be done in a second-stage clarifier.
- Filtration for additional solids removal.
- pH adjustment and de-chlorination tank (if needed) to condition the water before discharge.
- Residuals storage and pumping. During mine operations, the underflow from the clarifiers, which will be a dilute slurry of precipitated solids, will be pumped as-is to the tailings pumping system at the mill, where they will be blended with tailings and sent to the TSF.
- Hauling of treatment chemicals will average an estimated 40 truck trips annually during the operations period of the WTP.

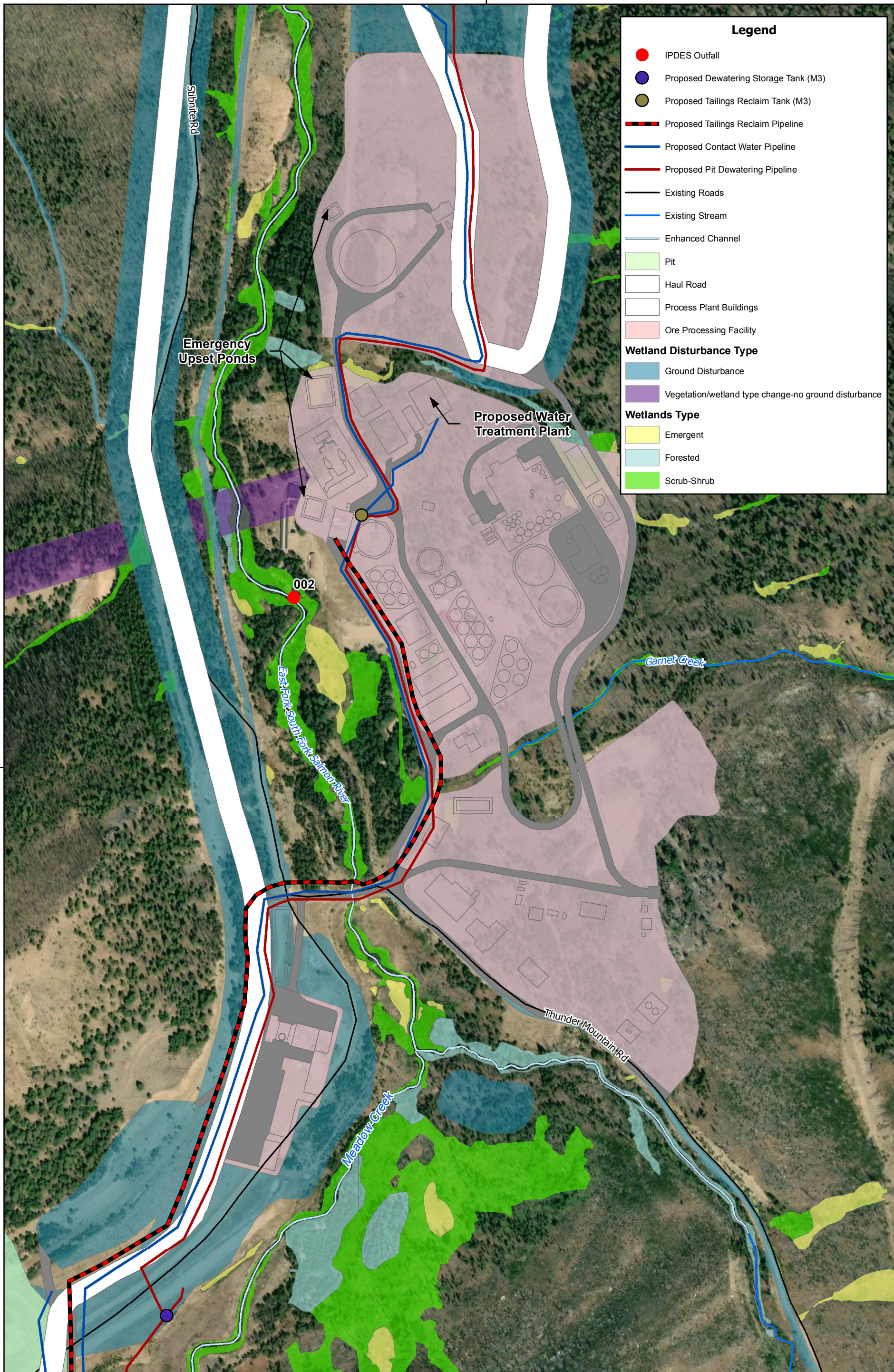

**Legend**

- IPDES Outfall
- Proposed Dewatering Storage Tank (M3)
- Proposed Tailings Reclaim Tank (M3)
- Proposed Tailings Reclaim Pipeline
- Proposed Contact Water Pipeline
- Proposed Pit Dewatering Pipeline
- Existing Roads
- Existing Stream
- Enhanced Channel
- Pit
- Haul Road
- Process Plant Buildings
- Ore Processing Facility

**Wetland Disturbance Type**

- Ground Disturbance
- Vegetation/wetland type change-no ground disturbance

**Wetlands Type**

- Emergent
- Forested
- Scrub-Shrub

4,973,838

4,973,838



**Figure 7-1**  
**Proposed Water Treatment Facilities**  
 Stibnite Gold Project

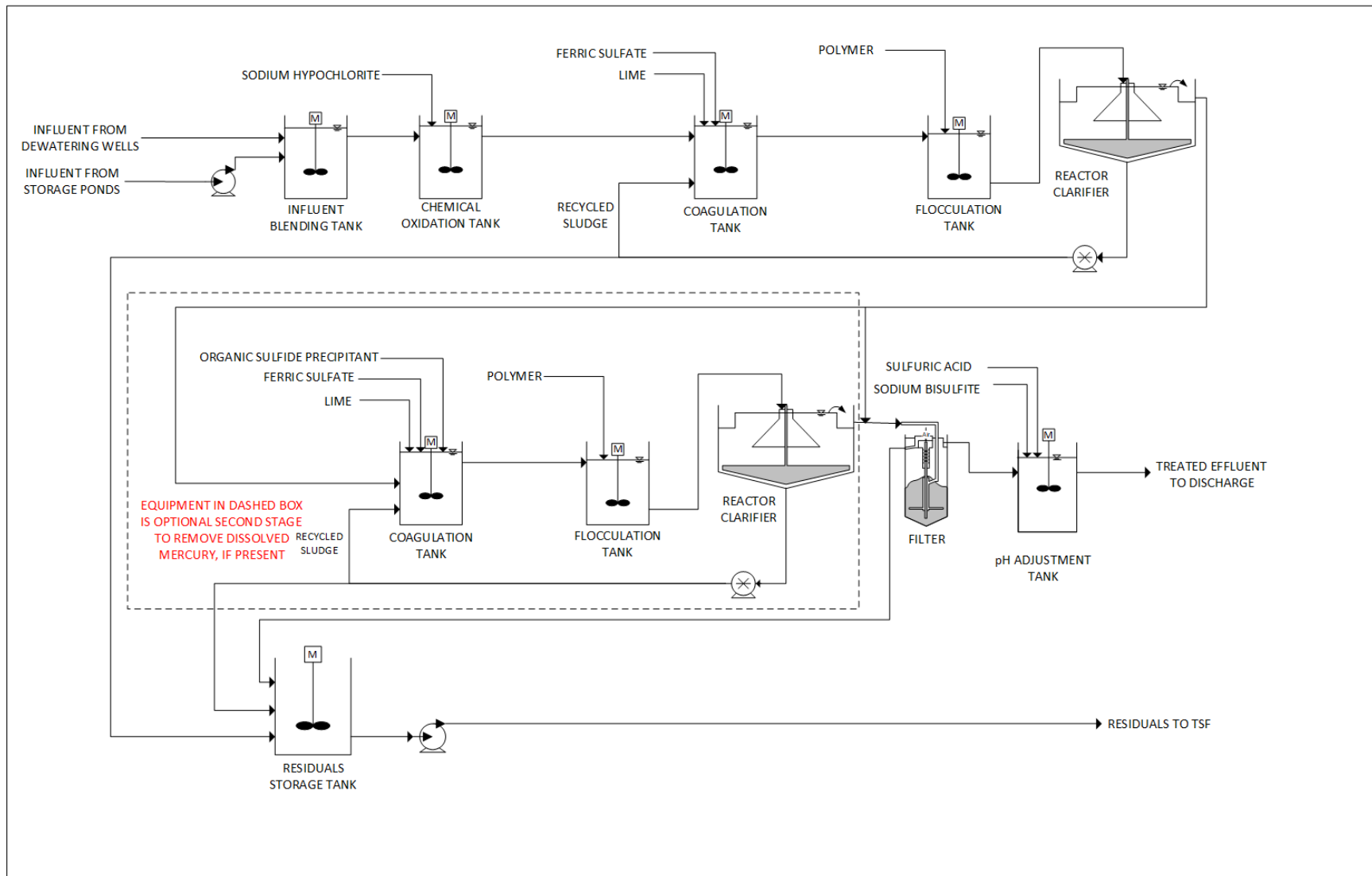

Figure 7-2. Process Flow Diagram of WTP During Operations

## 7.2 Equipment

Table 7-1 lists the major equipment proposed for the WTP.

**Table 7-1. WTP Major Equipment List**

Item
Influent pumps
Influent blending tank with mixer
Chemical oxidation tank with mixer
Coagulation tank with mixer – 1st Stage
Flocculation tank with mixer – 1st Stage
Reactor clarifier – 1st Stage
Coagulation tank with mixer – Optional 2nd Stage
Flocculation tank with mixer – Optional 2nd Stage
Reactor clarifier – Optional 2nd Stage
Media filter
pH adjustment tank with mixer and controller
Clarifier sludge pumps
Residuals storage tank with mixer
Residuals pumps to tailings thickener
Hydrated lime feeder (silo, mixer, slurry pump)
Other chemical feed systems

*Abbreviations:*

WTP = water treatment plant

The WTP will use approximately 100 kilowatts of power when operating at capacity.

## 7.3 Chemicals Needed

Table 7-2 lists the chemicals that will be used in the WTP during operations.

**Table 7-2. WTP Chemical List During Mine Operations**

Item	Average Annual Chemical Consumption During Operations (Years 4-12)
Sodium hypochlorite, 12.5 percent	15,000 gal/yr
Ferric sulfate, 60 percent	125,000 gal/yr
Hydrated lime	500,000 lb/yr
Organic sulfide precipitant	To be determined if required
Organic flocculant (polymer) for clarification	1,900 gal/yr
Sulfuric acid, 93 percent	2,400 gal/yr
Sodium bisulfite, 40 percent	2,000 gal/yr

*Abbreviations:*

gal/year = gallon per year

lb/year = pound per year

WTP = water treatment plant

## 7.4 Treatment Selection Considerations

Iron coprecipitation with mercury precipitation was selected for the WTP for the reasons described below.

**Ability to achieve treatment objectives.** As discussed in Section 6.2, iron coprecipitation can achieve the arsenic and antimony treatment objectives, and mercury (if it is associated with particles) treatment objectives. If necessary to remove dissolved mercury, the system will also include sulfide precipitation using an organic sulfide precipitant, which, as discussed in Section 6.3, can achieve the mercury treatment objective. Therefore, the WTP will achieve the treatment objectives. Table 7-3 summarizes the anticipated WTP effluent concentrations for the primary constituents of concern. Updated geochemistry modeling results from SRK (Appendix A) describe the anticipated effects of this treatment (along with other water management measures noted herein).

**Table 7-3. Anticipated Constituent Removal by WTP**

Constituent	Units	Concentration	
		WTP Influent	WTP Effluent
Arsenic	mg/L	0.40	<0.010
Antimony	mg/L	0.021	<0.0052
Mercury	ng/L	39	<12

Notes:

*Effluent values and removal percentages will be verified in laboratory bench testing.*

Abbreviations:

*mg/L = milligram per liter*

*ng/L = nanogram per liter*

*WTP = water treatment plant*

**Scalability.** If the influent flow rate is projected to be greater than the WTP design capacity, the system could be modified. Minor flow increases (up to approximately 20 percent) could be managed by increasing the chemical doses. Larger flow increases would be managed by temporary mobilization of additional equipment such as chemical feed pumps, tanks for mixing and settling, and filters.

**Impacts to other media.** No land impacts are anticipated during operation of the WTP. Solids produced by the WTP will be conveyed to the TSF. No air quality impacts are anticipated, even though the treatment tanks will be open to the atmosphere, as there will be no criteria pollutants or volatile organic compounds.

**Expected reliability.** The system is expected to reliably achieve the treatment objectives. On-site maintenance staff will conduct preventive maintenance.

**Confirmation testing required.** Laboratory bench-scale testing is needed before WTP design and construction to determine the operating conditions needed to achieve the arsenic and mercury treatment objectives. Specifically, the optimum chemical doses and operating pH of each stage, along with the need to oxidize the arsenic with hypochlorite, will be determined. Tests will also show whether an organic sulfide precipitant is needed to remove mercury or whether iron coprecipitation alone can achieve the mercury treatment objective. In addition, testing is needed to determine the conditions at which to operate the clarifier to prevent the residuals from becoming characteristic hazardous waste due to arsenic.

Bench-scale testing will be performed in the 6 months prior to mine construction using groundwater collected at the Project site. Particular well(s) will be selected based on similarity to predicted water quality Table 4-1. On-site pilot testing will be performed in Year -3 to further develop the operating conditions necessary to achieve the arsenic and mercury treatment objectives. Later, during operations when contact water is available (expected to be similar to predicted water quality in Table 4-3), tests will be performed for confirmation that WTP can treat flows during reclamation. If there is evidence of methylmercury in the TSF, tests will be performed to determine the ability of the WTP to remove it and whether the WTP will need to be modified when treating water from the TSF supernatant pond, as discussed in Section 8.1.

## 7.5 Temporary Treatment Systems Operating During Construction and Early Operations

Temporary treatment systems will be employed during construction and early operations and will include trailer-mounted or skid-mounted equipment packages that utilize the core technologies screened above. Iron coprecipitation or membrane treatment systems will be provided in these temporary systems. The membrane treatment systems are commonly provided by a wide range of vendors and can be setup in modular fashion with limited lead time. The mobile equipment packages for iron coprecipitation require additional lead time and more custom configurations. These systems will be procured in advance of need for the construction and early mine operation periods. The process flow diagram shown in Figure 7-2 for iron coprecipitation is representative of the temporary iron coprecipitation system. Figure 7-3 shows the process flow diagram for a temporary membrane treatment Plant.

In Years -2 and -1, an iron-coprecipitation-based temporary treatment system will be used to treat mine contact water. This initial temporary system will have a treatment flow capacity of up to 250 gpm. Residuals generated from the system will be dewatered and disposed in an appropriately permitted off-site landfill. During Years 1 through 3, a membrane treatment system will be used to treat mine contact water. The design flow capacity of the membrane treatment system will be 1,000 gpm. If a 95th percentile snowpack occurs in the winter of Year 3, additional treatment will be mobilized prior to the spring runoff period. Residuals from the temporary membrane treatment system will be discharged to the TSF.

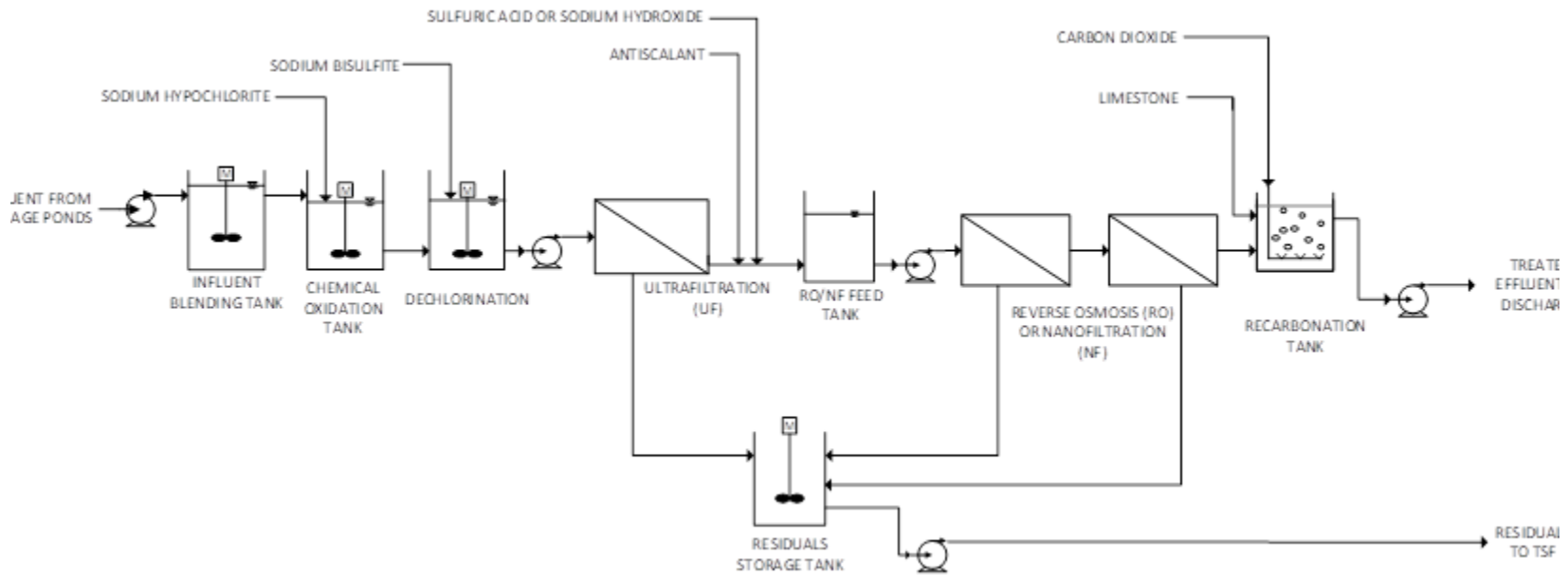

Figure 7-3. Process Flow Diagram of Membrane System

## 7.6 Sanitary Wastewater Treatment

Sanitary wastewater will be produced at the worker housing facility, administration building, warehouse, equipment maintenance shops, and surface facilities for the underground exploration program. The sanitary wastewater will be collected and transported to one or more sanitary WWTPs. A package Plant consisting of a membrane bioreactor or equivalent system will treat the water to meet applicable discharge requirements. There will be no connection between the sanitary WWTP and the centralized WTP. The sanitary wastewater treatment system(s) will discharge to the upper section of the EFSFSR near the location of the worker housing facility. The discharge volume will be relatively constant seasonally, but will vary between the construction, operations, and reclamation periods depending upon the number of employees present in each period. The discharge rate will be a very small proportion of the ambient flow in the EFSFSR.

## 7.7 Evaluation of Stream Temperature Effects Resulting from Treated Water Discharge

Midas Gold and BC evaluated temperature effects resulting from treated water discharge to the RIBs and the EFSFSR. The evaluation simulated storage and potential warming of contact water runoff in the contact water storage ponds, potential warming of both contact water and dewatering water in the WTP, and discharges of WTP effluent to either RIBs or direct discharge to the EFSFSR near Garnet Creek. Effects were first evaluated as monthly average flow and temperature values relative to observed data collected by the USGS at Gage 13311000 (EFSFSR at Stibnite, below Meadow Creek). Effects were also evaluated relative to the previous ModPRO Alternative simulations that did not include treated water discharge for the maximum weekly summer condition for comparison of simulated maximums and simulated averages during low flow, warm conditions when temperature impacts are potentially greatest. This evaluation did not consider engineering solutions that can be employed to bring about temperature change in either the storage ponds, or between the treatment system and the receiving waters. A variety of proven approaches are available to adjust effluent temperature to meet IPDES permit requirements. Such technology would also allow for control of temperature changes occurring on timesteps shorter than the monthly averages simulated in this effort.

### 7.7.1 Approach

This section describes the methods, inputs, and assumptions used to evaluate potential temperature effects associated with the storage and treatment of contact water and dewatering water at the WTP, and discharge of effluent to the RIBs and EFSFSR.

#### Contact Water Ponds

Eight contact water ponds will be located on the Project site. Table 2-1 summarizes the location, duration, and characteristics of these ponds. Contact water consisting of stormwater and non-stormwater runoff from the proposed mine facilities would be routed to these ponds and stored until treatment at the WTP. Monthly average runoff temperatures in this analysis were assumed equal to the warmest monthly averages observed at temperature monitoring locations in Meadow Creek or East Fork Meadow Creek (Table 7-4 and Table 7-5). The average of the daily averages was calculated each month, and the warmest of all the stations was selected.

**Table 7-4. Monitoring Stations Used to Develop Contact Water Runoff Temperatures**

Waterbody (Site ID)	Start Date	End Date
Meadow Creek near Stibnite, ID (13310850)	5/18/2012	8/12/2019
Meadow Creek upstream of Hangar Flats (MWH-003)	9/28/2013	8/2/2016
Meadow Creek at EFSFSR confluence (MWH-004)	9/14/2014	8/3/2016
East Fork Meadow Creek at Meadow Creek (MWH-006)	9/28/2013	8/2/2016
Meadow Creek above USGS Gage (MWH-034)	9/28/2013	8/3/2016

*Abbreviations:*

EFSFSR = East Fork of the South Fork of the Salmon River

ID = identifier

USGS = United States Geological Survey

**Table 7-5. Monthly Average Temperatures Applied to Contact Water Runoff Temperature**

Month:	1	2	3	4	5	6	7	8	9	10	11	12
Mean Temperature °C	0.7	0.9	1.3	2.9	4.7	8.5	11.0	10.9	9.4	5.1	1.4	1.0

*Abbreviations:*

°C = degree Celsius

Inflow volumes to the contact water ponds were based on the treatment system flow analysis described in Section 3.1. The total contact water volume estimated by month was apportioned to the contact water ponds based on volume and whether the pond was in service during that part of the mine life. Water yields for the average and 95th percentile flow conditions were generated as part of the treatment system flow capacity analysis and both conditions were evaluated with a mass balance analysis. Predicted stream flows and temperatures for the 95th percentile flow condition were very similar to the average water yield (Section 7.7.2). Because the results were so similar, only the average water yield scenario was evaluated with the stream a pit lake network temperature (SPLNT) model for simulation of maximum weekly summer condition maximum and average temperatures.

Withdrawal rates from the ponds routed to the WTP were based on the treatment system flow capacity analysis. Withdrawal rates were established to: (1) minimize the holding times of contact water during the summer season and therefore minimize potential heating, and (2) fully drain the storage ponds prior to each annual freeze to allow storage of spring runoff when the greatest capacity is needed.

The greatest potential for increased temperatures within the treatment system occurs during summer warming of water stored in ponds. A General Lake Model (GLM) was developed to simulate temperature changes in a contact water pond with the characteristics of pond MD-1, which is the largest of the proposed ponds that is slated to be in service for the entire mine operation period. This pond was selected because it accounts for approximately 25 percent of the total system storage capacity during the operations period, and it allows for the evaluation of potential impacts for each year of operations.

**Dewatering Water**

As described in Section 2.2.2, dewatering groundwater not used for freshwater makeup will be treated in the WTP along with contact water. The amount dewatered will then be infiltrated to the

alluvial groundwater system through the RIBs. Dewatering groundwater routed to the RIBs will be treated to the same standards as water discharged directly to the EFSFSR.

The temperature of the dewatering water routed to the WTP was assumed to be 7.3 °C. This is based on the average of the median bedrock and median alluvial temperature data provided in the 2018 Water Quality Summary Report (median bedrock temperature of 7.6 °C [n=321] and median alluvial temperature 7.0 °C [n=804]).

Monthly dewatering volumes sent to the WTP and discharged through the RIBs were based on the treatment system flow capacity analysis described in Section 3.1. Potential cooling of water discharged to the RIBs was not accounted for in this analysis and was assumed equal to that discharged from the WTP. In reality, water passing through the RIBs, or shallow groundwater flowing into the stream because of the mounding associated with the RIBs, would have passed through the subsurface materials. This would likely cool the water slightly during warmer months and potentially more so in the winter months when the WTP effluent temperature is higher than ambient air and shallow groundwater temperatures.

### **Potential Warming in the WTP**

Based on the process steps and duration in the WTP, minimal warming is anticipated in the WTP because there are no processes that specifically add heat load. Based on the temperature differential between the water being treated (a mix of contact water and dewatering water) and the air temperature within the WTP, warming would typically be 0.25 to 0.5 °C. A warming of 1 °C is projected for a water temperature of 1 °C and a WTP air temperature of 25 °C. This degree of temperature differential and potential warming is highly unlikely; therefore, a value of 0.5 °C was used.

### **7.7.2 Results**

The potential changes to EFSFSR temperatures are provided as monthly averages relative to recent observations (2012 to 2019) and as simulated maximums and averages compared to the ModPRO simulations without water treatment. In the summer months, there is minimal change in the simulated stream temperatures during the maximum weekly summer temperature condition or in monthly averages. In the winter, simulated stream temperatures at the point of discharge are projected to be higher than ambient conditions. However, air temperatures in the winter months are typically less than 0 °C (Figure 7-4). As Midas Gold works through the IPDES permitting and Endangered Species Act Informal Consultation processes with the agencies, standard engineering solutions that leverage the cold ambient air temperatures can be evaluated to ensure permit limits would be met. Results are further described below.

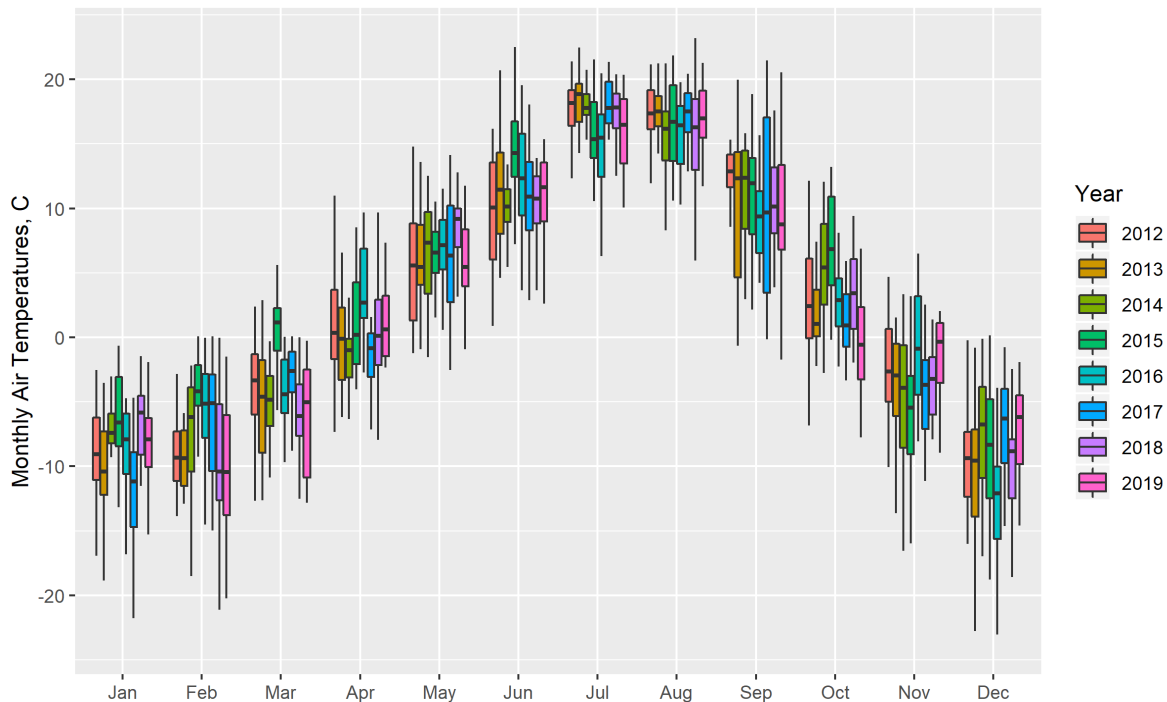

Figure 7-4. Distribution of Monthly Air Temperatures (boxes are 25th, 50th, and 75th percentile values for the daily average temperatures)

## 7.8 Comparison of Monthly Average EFSFSR Flows and Temperatures with Treated Water Discharge

The treated water discharge temperature analysis relies on monthly inputs for the water balance associated with the contact water ponds, dewatering rates, and treatment capacity. Therefore, WTP effluent flow rates and temperatures are simulated as monthly averages. The amount of WTP effluent discharged to the RIBs each month is equivalent to the amount that was dewatered that month. The amount discharged directly to the EFSFSR represents the balance of the treated water. Because the two sources of water will be treated in the same processes at the WTP, the WTP effluent will have the same monthly average temperature whether the water is discharged to the RIBs or to the EFSFSR.

A mass-balance approach was used to predict changes in stream flow and temperature relative to existing ambient conditions in the EFSFSR downstream of Meadow Creek using data collected at United States Geological Survey (USGS) gage 13311000 from 2012 to 2019. There are some periods within this record for which data are not available. Figure 7-5 shows the simulated monthly average stream flow resulting from the WTP effluent discharge to the RIBs and EFSFSR compared to flows recorded from 2012 to 2019. The flow effects are displayed for each mine year individually, but because the flows are so similar for each mine year, the lines representing the mine years are stacked and appear as one thick line. Treated water discharge has minimal effect on monthly average flow compared to the ambient conditions reported by USGS.

Figure 7-6 shows the simulated temperatures for the 12 mine years simulated for the Plan. Three of these years (3, 8, and 12) are distinguished on the figure in a darker color to represent the range of

discharge conditions evaluated in the SPLNT model (see Section 7.9 for an explanation of why these years were selected and how they were evaluated in SPLNT). The other mine years are shown as a single color.

In the warm, low-flow periods (July, August, and September), there is very little change in stream temperature for the average water yield scenario which represents the typical condition (Figure 7-6). For the 95th percentile scenario, temperatures in the EFSFSR from July to September are usually similar to those observed by the USGS and sometimes 1.5 to 2 °C cooler depending on the mine year.

Results of the water temperature analysis for the treated water indicate that increases in ambient EFSFSR water temperatures would be limited to late fall through spring (Figure 7-6). One of the key beneficial uses during this period is the incubation and emergence of salmonids, specifically the federally listed Chinook salmon and bull trout<sup>8</sup>. These species spawn in the late summer to fall, and their eggs incubate during the late fall and winter. Young start to emerge in late winter and spring. The temperature analysis indicates that the discharges could raise ambient stream temperatures during the incubation/emergence periods for Chinook salmon and bull trout by up to 4 °C during periods when ambient stream temperature are about 0 °C. Optimal incubation temperatures for salmonids vary, but are generally warmer than 4 °C. McCullough (1999) and McCullough et al. (2001) cite 8 degrees Celsius °C being optimal incubation temperature for most salmon species. Optimal incubation temperatures for bull trout eggs and rearing larvae are generally reported to be in the range of 2 to 10 °C (Buchanan and Gregory 1997; Goetz 1989; McPhail and Murray 1979).

Therefore, the discharge(s) are projected to increase winter-spring water temperatures to levels closer to optimum for incubation and emergence for Chinook salmon and bull trout. The length of the EFSFSR for which water temperatures would be raised during the winter-spring period would be very limited, as mixing of the discharge with colder ambient streamflow would result in water temperatures being lowered rapidly within a relatively short stream reach, especially given the cold air temperatures and limited solar input during this period. Additionally, developing eggs and larvae would be in the gravel and likely influenced partly or primarily by shallow groundwater and its associated temperatures. Research on the inter-gravel temperatures indicates that they are frequently warmer than the stream water temperature during colder months, influencing the development of salmonid eggs (Cassie 2006). The affected reach of the EFSFSR is reported to have limited spawning as documented by limited evidence of redds during redd surveys and lower spawning area suitability due to its higher gradient and predominantly larger substrates.

As Midas Gold works through the permitting and Endangered Species Act Informal Consultation processes with the agencies, if further concerns arise regarding the effects of this incremental increase in winter water temperatures in this reach of the EFSFSR, Midas Gold would explore opportunities to use cold ambient air temperatures to lower discharge temperatures to minimize this localized effect, if deemed necessary to support salmonid incubation and emergence conditions.

---

<sup>8</sup> The analysis indicates that the discharges would result in minimal change in stream temperatures during the spring-summer incubation and emergence period for steelhead, from April to mid-August.

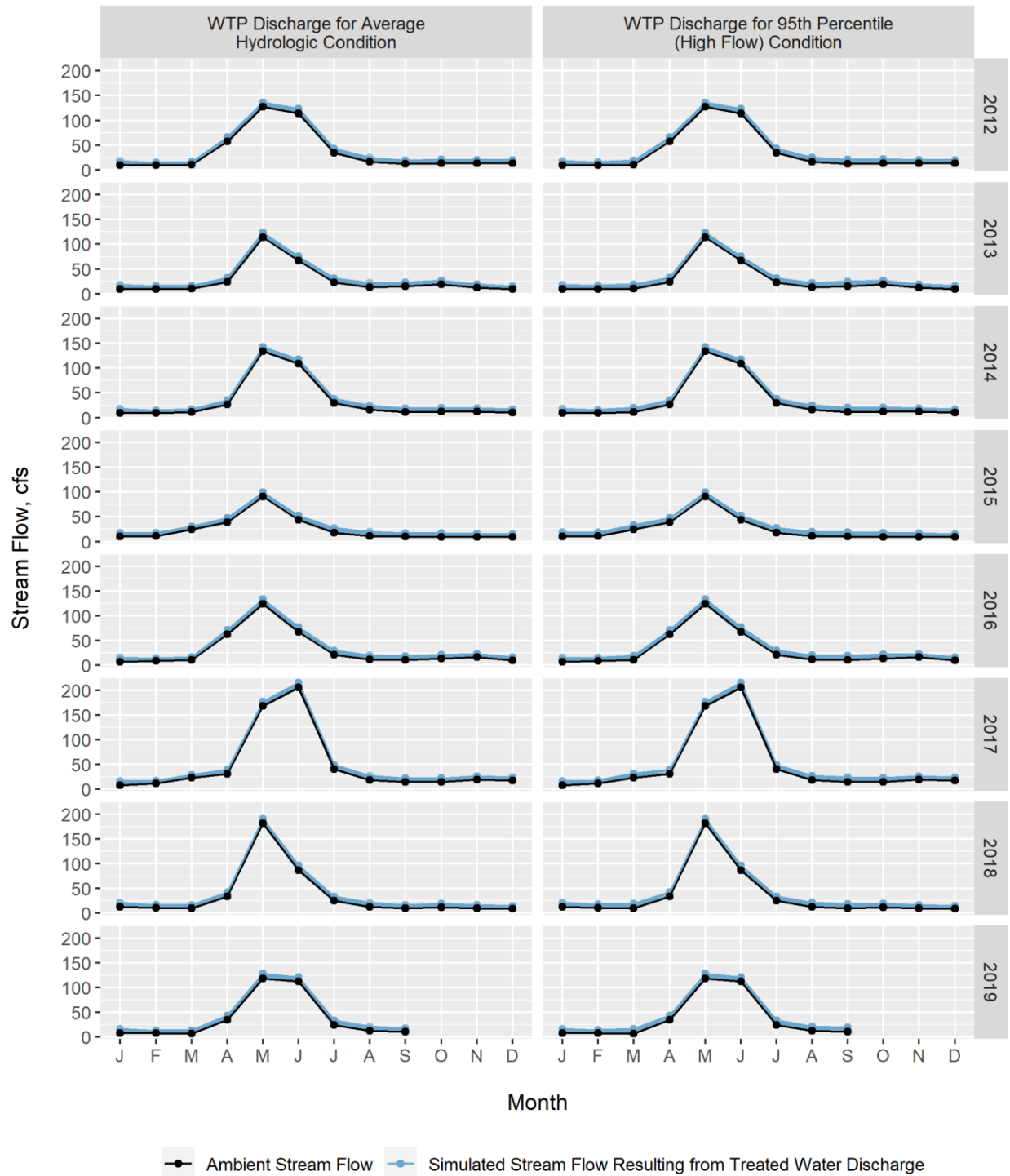

Maximum WTP discharge is similar under average and 95th percentile hydrologic conditions due to WTP capacity.

Figure 7-5. Estimated Stream Flows in EFSFSR below Meadow Creek Resulting from Treated Water Discharge Compared to USGS Observations at Gage 13311000



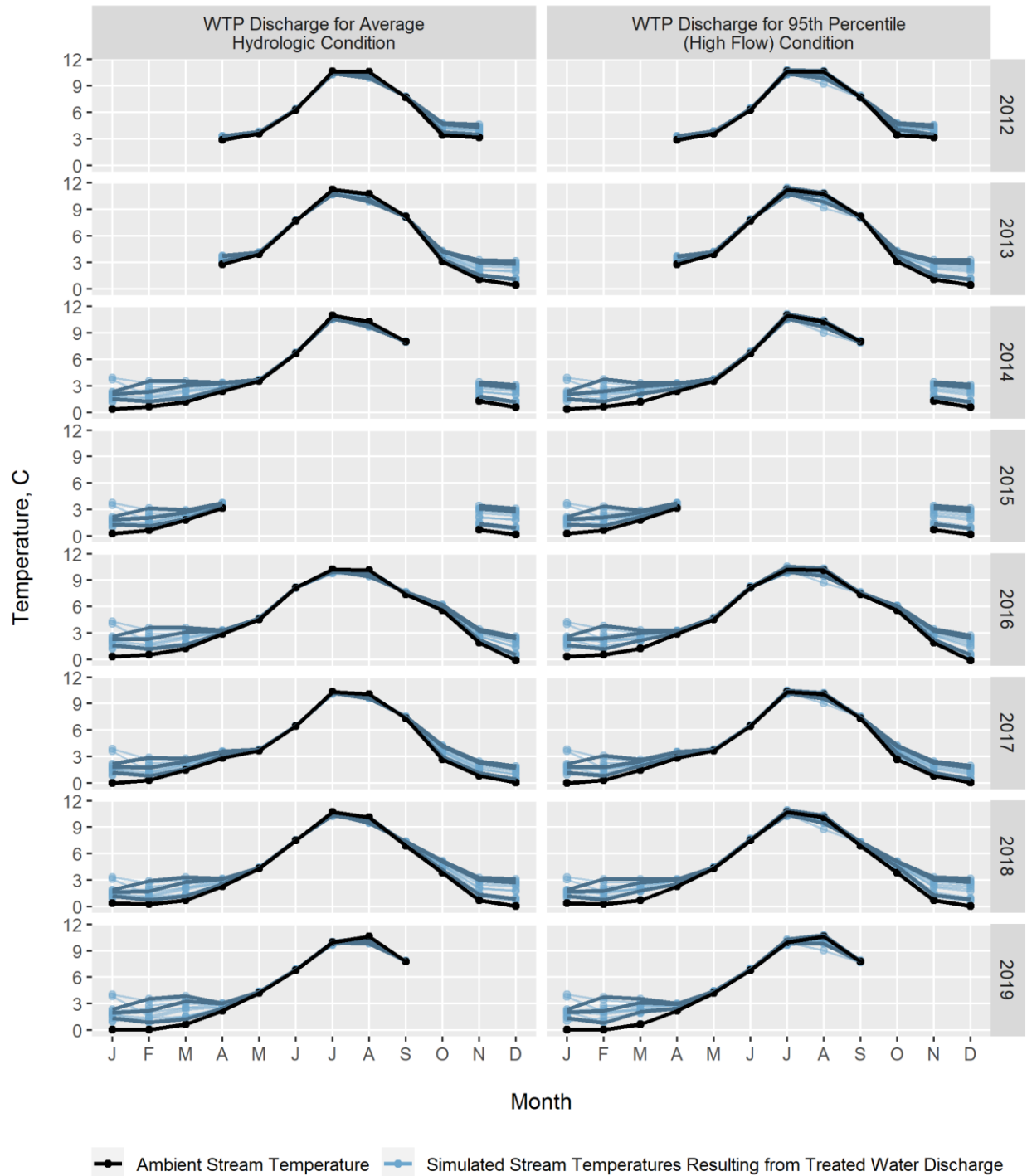

Midas Gold will work with the agencies during the IPDES permitting and Endangered Species Act Information Consultation to determine if engineering solutions are needed in the winter months to meet permit limits.

Figure 7-6. Estimated Stream Temperatures in EFSFSR below Meadow Creek Resulting from Treated Water Discharge Compared to USGS Observations at Gage 13311000



## 7.9 Comparison of Simulated Maximum and Average Temperatures for the Maximum Weekly Summer Condition

In addition to evaluating the monthly average stream flows and temperatures relative to ambient conditions, water balances for Years 3, 8, and 12 and the average water yield were selected for evaluation in the SPLNT model. The SPLNT model evaluates the impacts of mine operations on simulated maximum and simulate average conditions for warm, low-flow periods. SPLNT model output for each scenario are compared for the EFSFSR near Garnet Creek and accounts for the WTP effluent discharge to the RIBs and to the EFSFSR.

For this evaluation, the ModPRO End of Year (EOY) 6 configuration and water balance was used as the basis of comparison. Under the ModPRO, the configuration and water balance in terms of diffuse flow rates and headwater flows is similar for EOY6 and EOY12, and either could have been selected for this analysis. Diffuse flow inputs are constant inputs over the length of a stream reach and are calculated by differencing the gaging stations at the upstream and downstream points of the reach. Diffuse flow temperature is estimated as the average of mean ambient air temperature and the average of site-specific seep/adit water temperature. Diffuse flow inputs are described in Section 4.6.3 of the Final Stibnite Gold Project Stream and Pit Lake Network Temperature Model Existing Conditions Report (BC 2018d). A comparison to the No Action simulated temperatures is also provided. The maximum weekly summer condition was developed using July 29, 2016, as the representative day due to the steady state low flows, warm temperatures observed, and maximum number of temperature observations across the Project site (BC 2018d).

Using the EOY6, ModPRO configuration for the maximum weekly summer condition, three mine years were evaluated for comparison to the ModPRO simulations without water treatment. Figure 7-7 shows the average discharge flow rates from the WTP to the RIBs and to the EFSFSR for the July/August period of each mine year using the average water yield. Figure 7-8 shows the shows the average effluent temperature from the WTP for July and August; discharge temperatures to the RIBs and the EFSFSR are the same. The three mine years selected for analysis in the SPLNT model represent the range of conditions and include the following:

- Year 3 - low RIB discharge, low surface water discharge, warm effluent temperature
- Year 8 - high RIB discharge, low surface water discharge, low effluent temperature
- Year 12 - high RIB and surface water discharge, moderate effluent temperature

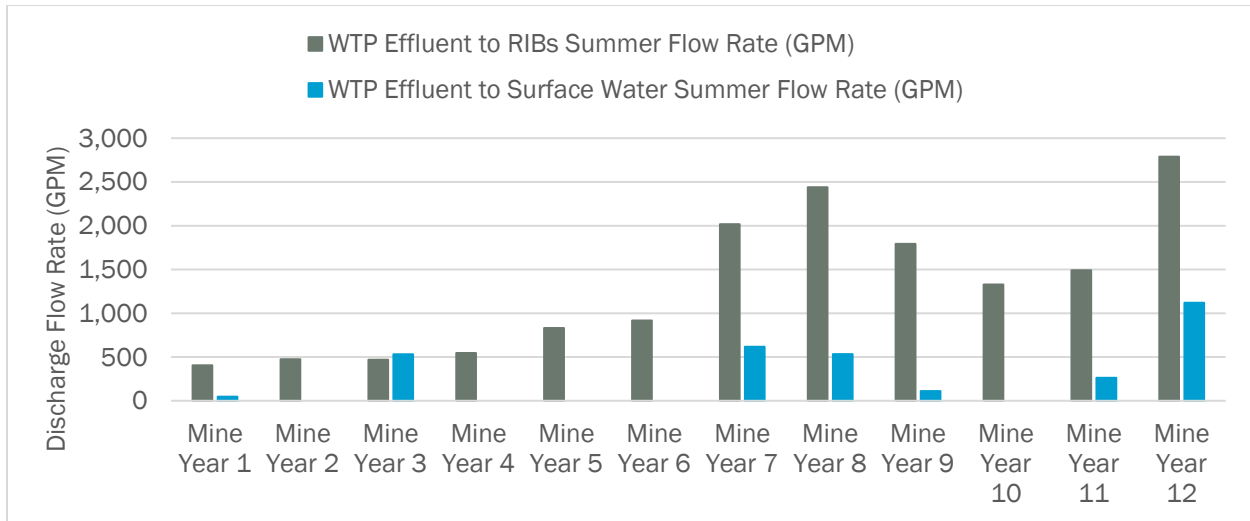

**Figure 7-7. Average Discharge Flow Rate to the RIBs and Surface Water for July/August by Mine Year for Average Water Yield Scenario**

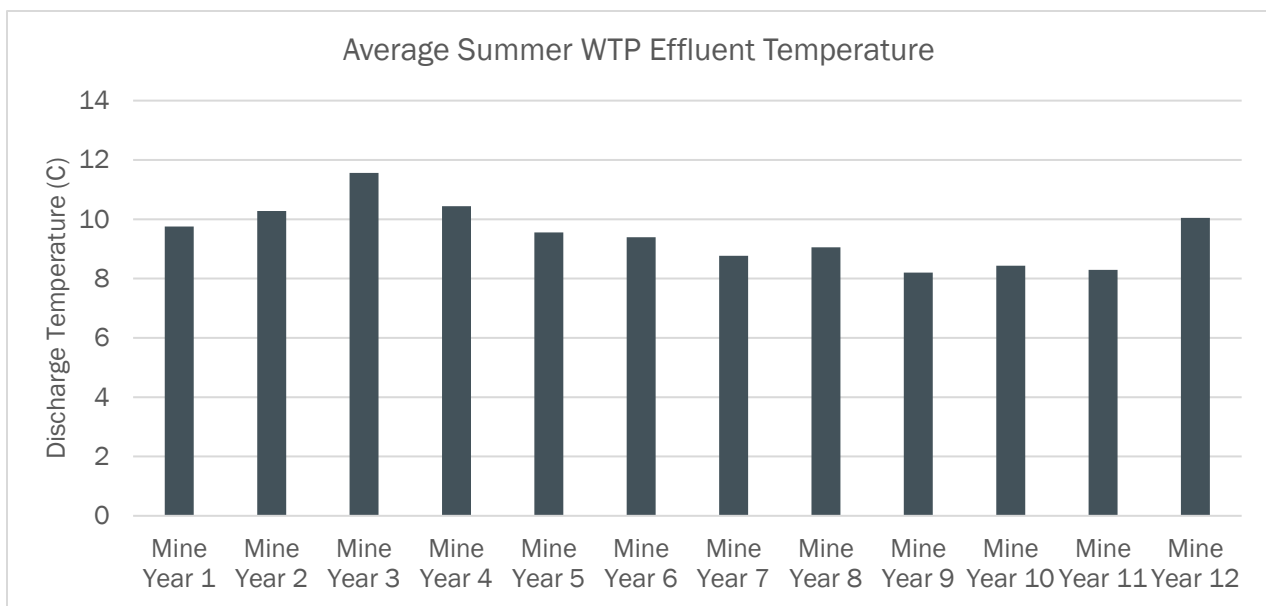

**Figure 7-8. Average WTP Effluent Temperature for July/August by Mine Year for Average Water Yield Scenario**

Table 7-6 shows the inputs for the SPLNT model that were adjusted to compare the treated water discharge simulation to the Mod PRO simulation and No Action Alternative. The diffuse flow rates and temperatures were revised in the three reaches adjacent to where the RIBs would be located on lower Meadow Creek and the EFSFSR upstream and downstream of Meadow Creek. The surface water discharge was simulated on the EFSFSR upstream of Garnet Creek. The inputs for the ModPRO and No Action Alternatives are provided for comparison.

**Table 7-6. SPLNT Model Inputs for the Evaluation of Three Mine Years for the Plan, Average Water Yield Scenario, Maximum Weekly Summer Condition**

Scenario	Summer Temperature of WTP Effluent and Diffuse Flow Inputs (°C)	Summer Diffuse Flow Rates which include RIBs (gpm)	Surface Water Discharge Flow Rate (gpm)	WTP Effluent Temperature (°C)
Plan, Year 3	11.6	469	531	11.6
Plan, Year 8	9	2,439	533	9
Plan, Year 12	10	2,788	1121	10
ModPRO, EOY6	11.9-13.9	377	N/A	N/A
No Action	11.9-13.9	507	N/A	N/A

**Abbreviations:**

°C = degree Celsius

EOY = end of year

gpm = gallon per minute

ModPRO = Modified Plan of Restoration and Operation

N/A = not applicable

RIB = rapid infiltration basin

SPLNT = stream and pit lake network temperature

WTP = water treatment plant

The results of the comparison are provided in Figure 7-9 and Figure 7-10. Simulated average temperatures for the maximum weekly summer condition for each treated water discharge scenario are similar or below the ModPRO simulation and No Action Alternative in the EFSFSR near Garnet Creek at the surface water discharge point (Figure 7-9). Simulated maximum temperatures for the maximum weekly summer condition for each Plan scenario are within 0.5 °C warmer than No Action in Year 3 and at least 1.5 °C cooler than No Action in Years 8 and 12 (Figure 7-10). All of the treated water discharge scenarios are cooler than the ModPRO simulation when comparing the simulated maximum temperatures. For the ModPRO EOY6 scenario, the diffuse flow temperatures were assumed the same as the No Action Alternative, but the diffuse flow rates are approximately 25 percent lower than the No Action Alternative due to net decreases in diffuse flow associated with dewatering and RIBs. The result is a simulated maximum summer temperature approximately 1 °C higher under ModPRO EOY6 compared to No Action. For Treated Water Discharge Simulation Mine Year 3, the diffuse temperature is slightly less than No Action (0.3 °C), and the diffuse flow rate is 8 percent lower than No Action due to the net effect of hydrologic changes; the simulated maximum summer temperature is approximately 0.5 °C higher under the Year 3 scenario compared to No Action. For Years 8 and 12 with a Treated Water Discharge Simulation, the diffuse flow rates are approximately 5 times higher than No Action due to the increased volume discharged to the RIBs, and the maximum summer temperatures are 1.5 to 1.7 °C cooler than No Action.

Reach-averaged temperature output for the ModPRO with and without the WTP are provided in Appendix B Table B-1. The water balance and stream temperatures for the EOY6 and EOY12 ModPRO configurations are very similar and results would be the nearly the same for EOY6 and EOY12.

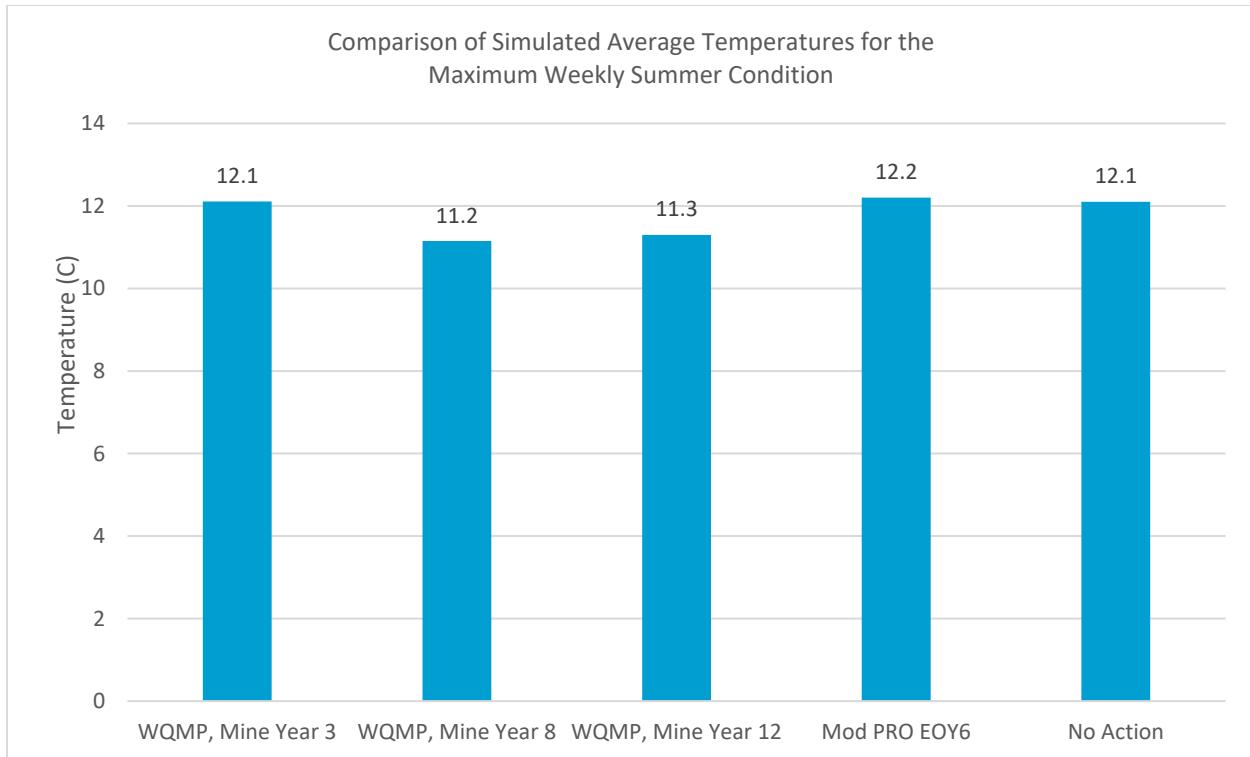

**Figure 7-9. Simulated Average Temperatures for the Treated Water Discharge Scenarios Under the Maximum Weekly Summer Condition using the SPLNT Model**

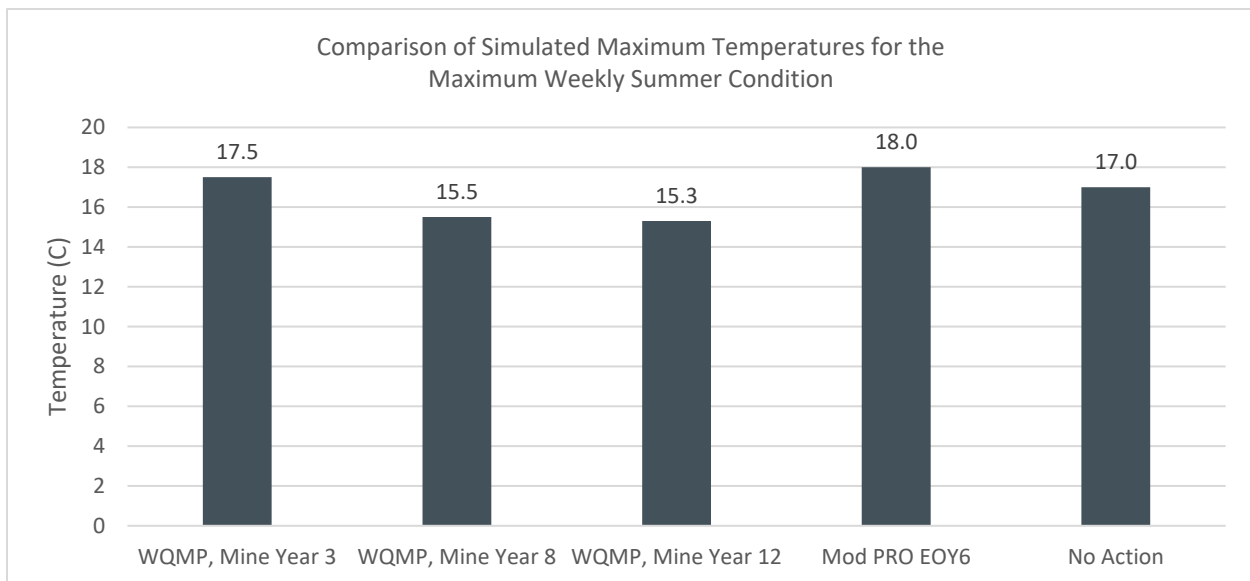

**Figure 7-10. Simulated Maximum Temperatures for the Treated Water Discharge Scenarios Under the Maximum Weekly Summer Condition using the SPLNT Model**

For the post-closure period and the maximum weekly summer condition, the WTP would result in similar stream temperatures as those simulated for the ModPRO if the water is drawn from the



surface of the pit lake. The major source of water post-closure to the WTP is the discharge from Hangar Flats pit lake. Rather than discharge to Meadow Creek, the WTP would discharge to the EFSFSR upstream of Garnet Creek and the RIBs would be decommissioned so all WTP effluent would discharge to the EFSFSR. The volume of water discharged during the maximum weekly summer condition based on the Plan water balance (0.035 cubic meters per second [cms]) is similar to that assumed for the ModPRO model (0.033 cms); these discharges are 1.23 cubic feet per second (cfs) and 1.16 cfs, respectively. The temperature of the effluent, if water is withdrawn from the surface of the pit lake, would also be similar assuming a 0.5 °C increase in the WTP effluent (21.6 °C rather than 21.1 °C assumed for the ModPRO). However, Midas Gold can control the depth of water withdrawn from the pit lake for treatment at the WTP and the depth of water withdrawn can be managed based on season and ambient conditions to achieve the most appropriate temperature. Based on GLM modeling conducted for the ModPRO (BC 2019), pit lake temperatures from depths of 5 to 20 meters range from 11 °C to less than 6 °C, and water from depths of 5 to 20 meters can be withdrawn for treatment. In this case, the 0.5 °C increase in the WTP effluent temperature would result in much lower discharge temperatures than those currently simulated under the ModPRO (i.e., 11.6 °C compared to 21.6 °C). Reach averaged maximum, minimum, and average temperatures are provided for EOY18 (Appendix B, Table B-2) and EOY112 (Appendix B, Table B-3) summer conditions for the ModPRO with and without the WTP to bracket conditions for the post-closure period. For the Plan scenarios, two example WTP effluent temperatures are provided: 21.6 °C represents withdrawal from the pit lake surface with 0.5 °C warming in the WTP and 11.5 °C represents withdrawal from the pit lake subsurface with 0.5 °C warming in the WTP; cooler water can be withdrawn as needed. In reach 25 for EOY18 and EOY112 (Appendix B, Table B-2 and Table B-3), the simulated maximum temperatures are within 0.02 °C of the ModPRO when the WTP effluent discharge temperature is assumed to be 21.6 °C, and up to 0.62 °C cooler than the ModPRO when the effluent discharge temperature is assumed 11.5 °C.

### Summary

A temperature analysis was developed to simulate the effects that this Plan would have on stream temperatures. In the summer months, there is little impact to monthly average temperatures or maximum and average temperatures under the maximum weekly summer condition. In the winter months (November through March), stream temperatures at the discharge point may increase from approximately 0 to 4 °C depending on the mine year. Midas Gold will work with the agencies during the permitting process and Endangered Species Act Informal Consultation to determine if mitigation measures are needed to meet permit limits. The ambient air temperature during the winter months is often at or below 0 °C; therefore, cooling the WTP effluent would not be an energy intensive process.

## 7.10 Potential Temperature Mitigation Measures

Midas Gold is currently evaluating additional temperature mitigation measures to those included in the ModPRO Alternative. These temperature mitigation measures are not specific to this Plan but are being considered as a part of Midas Gold's overall commitment to minimize environmental effects. The additional temperature mitigation measures being considered include the following:

- Increasing the restoration planting width from 7 to 18 feet on all restored stream reaches
- Stream bank planting of the enhanced EFSFSR reach that is currently disturbed to the width allowable by site constraints
- Revised planting prescriptions that include more spruce and willow trees than prescribed in the Conceptual Mitigation Plan (Tetra Tech 2019)

- Constructing a lake near the location of the present Yellow Pine pit lake to mimic its temperature-moderating effects
- Maintaining low-flow pipes within stream diversions until restoration plantings have matured to provide adequate shade
- Implementing water treatment plant design refinements to lower effluent temperature prior to discharge to the RIBs or streams during the winter, as necessary
- Withdrawing water from depths of 5 to 20 meters in the Hangar Flats pit lake in the summer months to route cooler water to the WTP thereby resulting in cooler discharge temperatures to the EFSFSR

## Section 8

# Treatment During Reclamation and Post-Closure

Post-closure water treatment during reclamation and post-closure is anticipated for the following water sources:

- TSF supernatant pond water
- TSF post-closure consolidation and runoff waters
- Fiddle DRSF toe seepage water
- Yellow Pine pit dewatering water
- Hangar Flats pit lake water
- West End pit lake water (treatment if necessary)

Over the long term, as flows subside during post-closure, water treatment will be transitioned to passive treatment, except for the Hangar Flats and West End pit lakes. Passive treatment avoids the need for continuous operations staffing, chemical handling, and regular residuals management. However, during reclamation, TSF supernatant and consolidation water flows and contaminant loading will be large enough that active treatment will be used. The WTP used during mine operations will be modified, as necessary, to manage residuals if they can no longer be conveyed to the TSF during mine closure.

If multiple consecutive wet years occur, West End pit lake water may also need treatment. A contingent plan is presented below.

Although specifics of the Plan regarding the reclamation and post-closure periods are aligned with the ModPRO, this Plan can be adapted to all alternatives being evaluated for the Draft EIS. However, treatment of the Hangar Flats pit lake water in Alternatives 1, 3, and 4 would require a treatment plant with larger flow capacity.

## 8.1 Treatment at the WTP During Reclamation and Post-Closure

The centralized WTP will treat the TSF supernatant pond water, TSF consolidation waters until Year 21, Yellow Pine pit dewatering water for the 2.5 years after operations that it will be pumped to the RIBs, and the Hangar Flats pit lake overflow.

The projected flow-weighted-average water quality to the WTP for various years during reclamation and post-closure periods is shown in Table 4-3. The mass loading of mercury is projected to be higher during reclamation and post-closure than operations, due to its concentration in the TSF. However, projected mercury concentrations in the TSF are based on pilot testing of the ore processing circuit; better mercury removal (and thus lower concentrations in process water and tailings) is expected in the industrial-scale ore processing facility than was demonstrated in the ore processing pilot study used in these projections. If tests indicate that organic sulfide precipitant is needed to achieve the mercury treatment objective, it will be added. Therefore, the WTP is expected to meet treatment objectives.

### 8.1.1 Process Description

The WTP discussed in Section 7 does not include residuals dewatering and disposal, because during operations, the residuals, will be pumped to the ore processing facility and then to the TSF. During the early reclamation period, WTP residuals will continue to be transferred to the TSF for disposal. As shown by the black lining in Figure 8-1, the only new equipment needed will be a larger pump to convey the material to the TSF rather than only to the ore processing facility. Further into the reclamation period, new solids thickening will be required as shown by the black lining in Figure 8-2. The dewatered solids will be disposed in an off-site landfill. The system will generate approximately 180 cubic yards of dewatered solids per year.

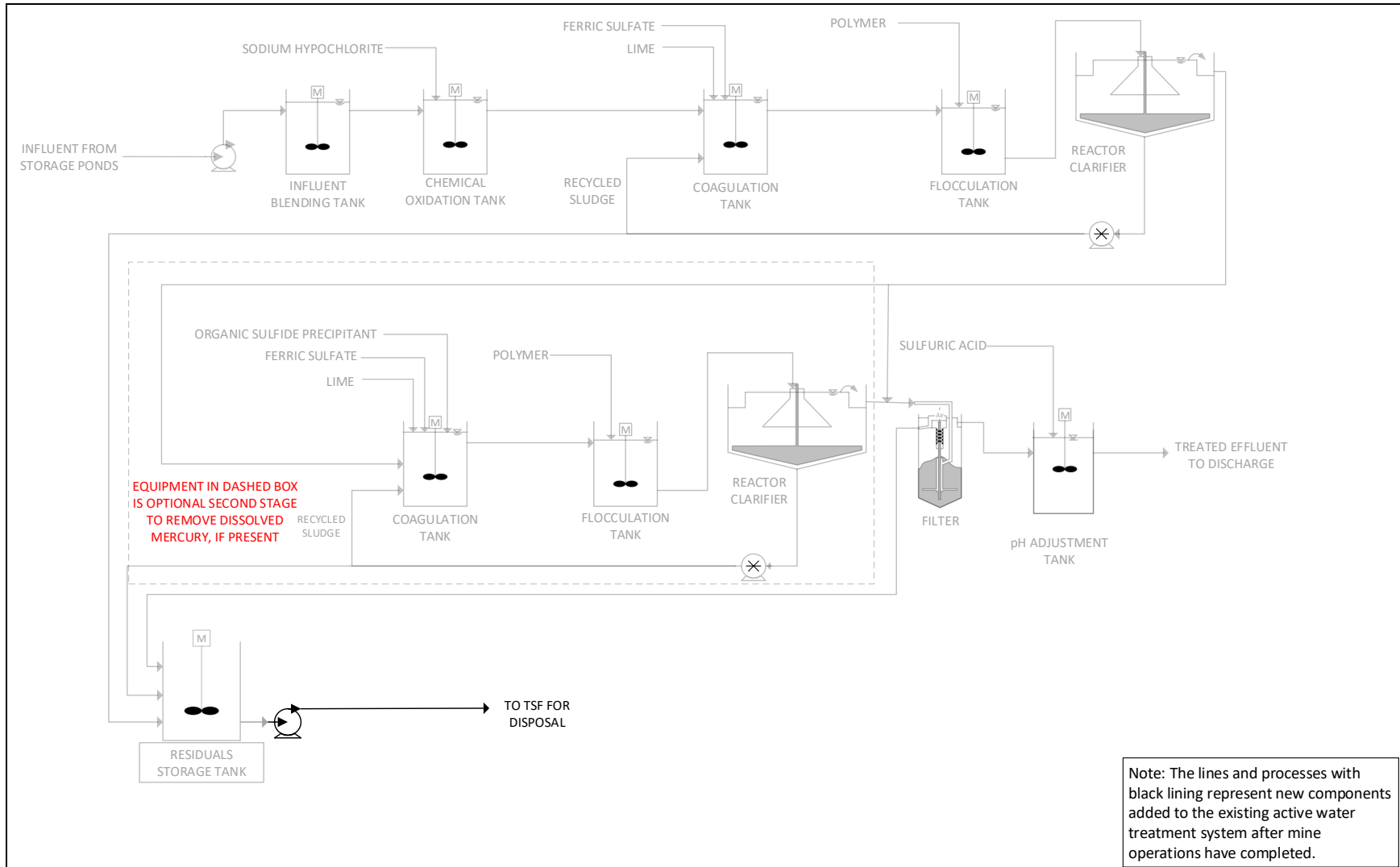

Figure 8-1. Process Flow Diagram of WTP During Reclamation and Post-Closure with Residuals Pumped to the TSF

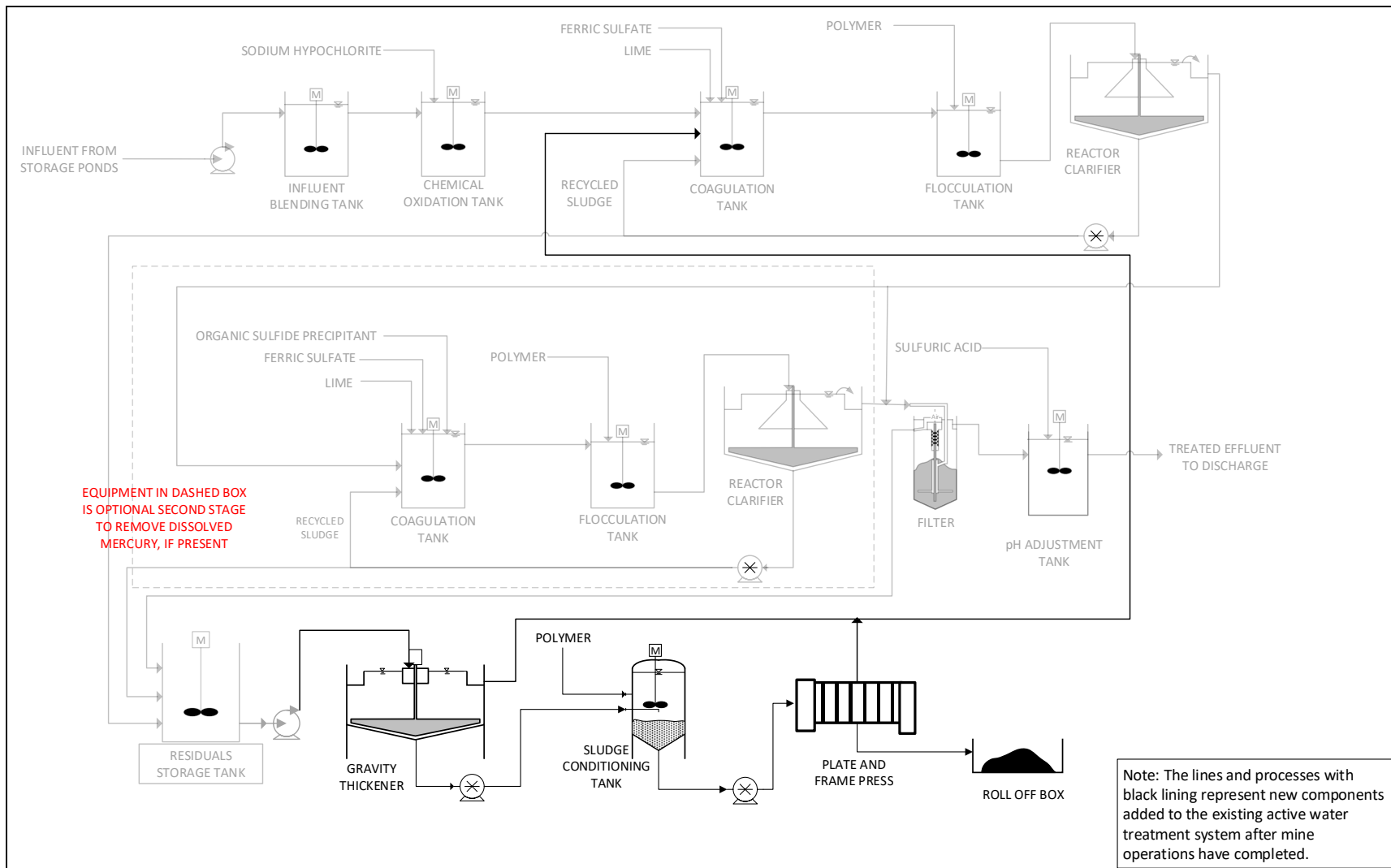

Figure 8-2. Process Flow Diagram of WTP During Reclamation and Post-Closure with Residuals Dewatering and Off-site Landfill Disposal

### 8.1.2 Equipment

As noted in Section 8.1.1, if the SGP continues to send WTP residuals to the TSF during reclamation, the only new equipment needed would be a larger sludge pump. If residuals are thickened, dewatered, and disposed off site, the major equipment listed in Table 8-1 will need to be installed.

**Table 8-1. Additional Major WTP Equipment Needed for Residuals Dewatering and Disposal**

Item
Gravity thickener
Thickened sludge pump
Solids storage/conditioning tank with mixer
Dewatering press feed pumps
Dewatering filter press or other selected dewatering technology
Filtrate return pumps
Chemical feed systems

Abbreviations:

WTP = water treatment plant

### 8.1.3 Chemicals Needed

Table 8-2 lists the chemicals that will be used in the WTP during reclamation.

**Table 8-2. WTP Chemical List During Reclamation**

Item	Average Annual Chemical Consumption During Post-Closure
Sodium hypochlorite, 12.5 percent	5,000 gal/yr
Ferric sulfate, 60 percent	65,000 gal/yr
Hydrated lime	260,000 lb/yr
Organic sulfide precipitant	To be determined if required
Organic flocculant (polymer) for clarification	1,300 gal/yr
Sulfuric acid, 93 percent	1,700 gal/yr
Sodium bisulfite, 40 percent	1,400 gal/yr

Abbreviations:

gal/yr = gallon per year

lb/year = pound per year

WTP = water treatment plant

The truck trips associated with the chemicals hauling is estimated at 30 per year based on the chemical consumption estimates listed in Table 8-2.

## 8.2 Treatment of TSF Consolidation Water and Runoff Post-Closure

As discussed previously, the TSF consolidation water will comingle with meteoric water falling on the TSF. Because of the quality of this water mixture, treatment will be required prior to discharge to Meadow Creek for approximately 30 years. During this time, the volume requiring treatment will decline. The active WTP used during operations will be used until flows with equalization considered have subsided to 750 gpm or lower, anticipated to begin in Year 21 (assuming a 12-year mine

operating life), at which point they can be treated using a passive treatment system. The passive system will consist of BCRs followed by aerobic VF wetlands.

The principal design criteria for an anaerobic BCR is the empty bed contact time, which can range from 18 to 36 hours. Flow within the BCR is vertical, with water applied to the surface and allowed to flow by gravity to the bottom of the reactor where it is collected in a gravel underdrain. For the SGP, the BCR will be constructed with an impermeable bottom liner and geotextile cover. The BCR geotextile cover is overlain with a soil cover to provide insulation from cold temperatures during the winter months. A perforated piping network located below the geotextile cover evenly distributes the influent across the top of the BCR. The perforated distribution pipe is usually buried into the media to protect from ultraviolet light and frost.

The principal design criterion for VF wetlands is the hydraulic loading rate, which can range from 5 to 15 gallons per day per square foot (Crites et al. 2014). The percolate from the VF wetlands is collected through underdrain piping and routed to an effluent monitoring station and then discharged.

The passive treatment system footprint is estimated to be up to 6 acres. Sizing estimates will be confirmed in pilot tests conducted during mine operations before the BCRs and VF wetlands are constructed. If the passive treatment system is unable to achieve the water quality targets, the active WTP will continue to be used in post-closure.

The BCRs are anticipated to have a 5- to 15-year service life, after which they would be rebuilt. VF wetlands are estimated to have a 25-year service life.

**Confirmation testing required.** Laboratory bench-scale testing and on-site pilot testing is needed before BCR and wetland treatment design and construction to determine the operating conditions needed to achieve the arsenic and mercury treatment objectives. Specifically, the hydraulic retention time, substrate blend, and system lifespan, will be determined. Tests will also show the rate at which the substrate is exhausted and the amount of residuals generated. This will determine the frequency of reconstruction required. The characteristics of the residuals will also be analyzed, which will inform the offsite landfill category requirements for acceptance of the residuals.

Bench-scale testing will be performed 5 years prior to the end of mine operations using waters generated at the Project site that are representative of the water quality anticipated to be discharged from the TSF and Fiddle DRSF during the post-closure period. On-site pilot testing will begin 4 years prior to the end of mine operations and will also use waters generated at the Project site that are representative of the anticipated post-closure flows.

### 8.3 Treatment of Fiddle DRSF Toe Seepage Post-Closure

The Fiddle DRSF toe seepage water that is anticipated to be present during post-closure is planned to be treated in its own passive treatment system consisting of a BCR and VF wetland. The Fiddle DRSF toe seepage passive system is expected to be constructed prior to the end of mine operations so that it can be brought online after mine operations have been completed. As described in Section 3.2.4, post-closure water treatment systems are assumed to be required to treat the Fiddle DRSF toe seepage in perpetuity.

The Fiddle DRSF toe seepage design flows developed in the post-closure design basis have a peak flow rate of 400 gpm. The design of the Fiddle passive treatment system will follow the same criteria as presented in Section 8.2 for the TSF passive treatment system. As with the TSF passive treatment system, if the BCR and VF wetland are unable to achieve the water quality targets, the Fiddle DRSF toe seepage will be routed to the active WTP for treatment and discharge.

## 8.4 Contingent Plan for West End Pit Lake Water Treatment

The West End pit lake is predicted to take decades to reach a level where spillage is possible, and occurrence of spillage beyond that time is highly dependent on the actual climate sequence (consecutive wet years) experienced. The modeled result of a historical climate sequence shows spillage only during 5 out of 100 years. Each of these discharge events is expected to last 3 to 6 months. More background on the modeling basis for the pit lake outflows is provided in the Final ModPRO Alternative Modeling Report (BC 2019b).

There could be decades during which there is no discharge to West End Creek. Rather than constructing a WTP for West End pit lake water that might sit idle for decades, temporary equipment will be used when needed, or actions taken to prevent discharge entirely. The water level in the pit will be monitored and, if it rises above a preset threshold elevation, a temporary treatment system will be mobilized and operated until the level has subsided to below that threshold and is projected to continue declining. The capacity and technology for the temporary treatment system will be selected based on the rate of water level rise, and may include enhanced evaporation, diversion of upgradient catchments, membrane treatment, or a combination of these and/or other measures. Treated water from West End pit lake will be released through an outfall to West End Creek at a location close to where the temporary treatment system will be placed (see Figure 2-1). Specific treatment provisions and the discharge location and configuration will be negotiated with IDEQ during the standard permit renewal process as mine closure approaches. Similar to the West End pit lake, in Alternatives 1, 3, and 4, Midnight pit is not backfilled and could have intermittent discharges during spring runoff periods of high snowpack years. Under those alternatives, the water level in the Midnight pit lake would be monitored and water within the pit lake would be treated using rented or mobile equipment to maintain the water level below a designated threshold to prevent discharge during the subsequent spring runoff period.

## Section 9

# Scalability

This Plan has been developed around the ModPRO— Alternative 2 in the NEPA review process—to focus the discussion and provide clarity in decision making and methodology. The Plan can be scaled to Alternatives 1, 3, and 4, each of which currently incorporates the alternative component of routing Meadow Creek through the Hangar Flats pit lake at mine closure. Selection and implementation of this alternative component would require that the design of the WTP undergo throughput capacity adjustments to treat a greater volume of water.

For both closure scenarios, current predictive water quality modeling suggests that Hangar Flats pit lake outflow would require treatment in perpetuity, requiring the WTP to stay in operation. However, for Alternatives 1, 3, and 4, the volume of water that would need to be treated is far greater than for the Alternative 2 scenario.

Adjusting this Plan to the other alternatives would start with an update to the current design basis, where the water generating features would be modeled for flow and constituent concentrations. The water flow data would then be combined with the water quality projections to develop flow weighted average concentrations for the inputs to the water treatment system. Water management strategies would be evaluated to equalize flows and reduce peak month flow rates. Once the new design basis was established, a reevaluation of the selected alternative would be performed. Based on the initial evaluations of the other alternatives, it is not anticipated that the treatment methodology would be significantly modified, but the flow capacity of the WTP would increase significantly in the post-closure period for alternatives in which Meadow Creek is routed through the Hangar Flats pit lake. The flow chart in Figure 9-1 shows the steps that have gone into developing the water treatment alternative and the design basis. If an alternative other than Alternative 2 is selected, the steps associated with the site-wide water balance, SWWC, water management and water treatment prefeasibility study will be updated prior to moving on to the technology confirmation steps. The adaptive management figure (**Error! Reference source not found.**) in Section 2 is also illustrative of the decision-making process through the water treatment evaluation and design process.

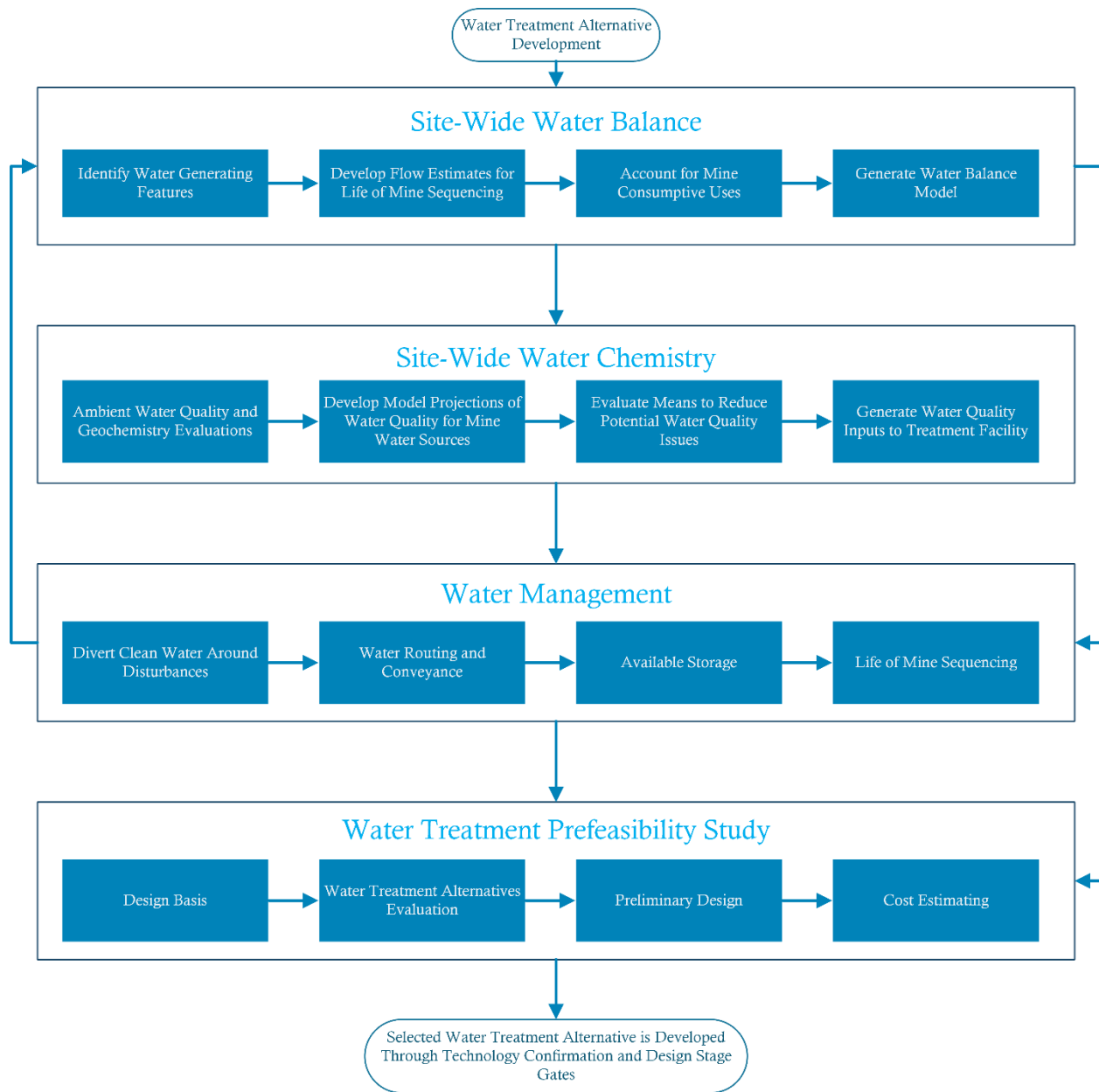

**Figure 9-1. Water Treatment Development Flow Chart**

To give context to the change in plant flow capacity and equalization volume required during the post closure period, the 2011-2016 record for USGS stream gages 13310850 (Meadow Creek) and USGS 133101000 (EFSFSR just below the Meadow Creek confluence) were used to estimate potential flows through the Hangar Flats pit lake. Flows were estimated by interpolation between the gages based on drainage area, as there is no stream gage located exactly at the location where Meadow Creek would enter the Hangar Flats pit lake. The estimated flows were then evaluated using



a spreadsheet equalization model. The results of the equalization model show that 7,000 ac-ft of storage is required to equalize the peak month flows (3,200 gpm median, 29,000 gpm 95th percentile) down to the annual average flow rate estimated at 7,500 gpm. For comparison without the Meadow Creek flow inputs, the 95th percentile monthly flowrate from Hangar Flats pit lake under Alternative 2, with no equalization and Meadow Creek routed around the lake, is estimated to be 2,350 gpm. Providing 7,000 ac-ft of storage would not be feasible at the Project site, so a more feasible storage volume of 1,000 ac-ft of storage was evaluated and the resultant 95th percentile maximum month treatment plant influent flow rate was estimated to be 25,500 gpm. The additional cost for treatment with the inclusion of Meadow Creek flow, not including costs for storage, is estimated to be approximately \$150M (+100 to -50 percent). This initial look at potential flows from the Hangar Flats pit lake with Meadow Creek routed through the lake indicates that treatment can be provided, but if Alternatives 1, 3, or 4 are selected, the water management efforts would have to focus on strategies to reduce peak flow rates. Strategies could include diversion of peak flows around the Hangar Flats pit lake, or other actions to divert the clean water of Meadow Creek during high-flow period around the waters requiring treatment within the Hangar Flats pit lake.

In summary, this Plan provides an approach to water treatment for Alternative 2, and the conceptual framework developed for operational and post-closure water treatment can be modified to accommodate the greater volumetric water treatment requirements of Alternatives 1, 3, and 4. In all alternative scenarios, treatment in perpetuity of surface water is anticipated; however, the construction and long-term operation of the larger-scale WTP necessitated by Alternatives 1, 3, and 4 would be challenging and costly.

## Section 10

# Projected Surface Water Quality

Water treatment discussed in this Plan will improve the quality of various sources of contact water, sanitary wastewater, and process water. The effect of this treatment will be an overall improvement in surface water quality leaving the Project site. At the same time, there will be a much larger volume of ambient meteoric water and groundwater discharge originating from areas outside of Midas Gold's mining and mine-related activities on the Project site. Some of the ambient water will be stormwater runoff from undisturbed areas entering tributaries to the EFSFSR, and some will be conveyed in diversion channels around various mine facilities. Some runoff will impinge upon legacy mining features that Midas Gold will not re-disturb, and some discharge may still occur from existing seeps and adits away from Midas Gold's proposed activities.

SRK revised the geochemical model it had previously prepared based on existing conditions and used the revised model to simulate the ModPRO scenario to account for the management and treatment of sources discussed in this Plan. The revised model predicts the quality of water at several nodes along the EFSFSR system on the Project site. SRK generated a technical memorandum (see Appendix A) summarizing the revised model and comparing the projected water quality under the ModPRO scenario without treatment to the ModPRO scenario with the treatment program discussed herein.

Modeling by SRK predicts that, during operations and post-closure, water quality in Meadow Creek and EFSFSR will generally be improved relative to baseline conditions (established between 2012 and 2015). The greatest degree of improvement is predicted for arsenic because ambient concentrations in the EFSFSR tend to be well above Idaho human health criteria for surface waters, and concentrations in untreated contact water and/or dewatering water are expected to be well above anticipated IPDES permit limits. The fact that predicted antimony and mercury concentrations in the contact and dewatering water are generally closer to anticipated permit limits is the reason those constituents are not reduced to the same degree as predicted for arsenic.

Water treatment will generally only affect a minor portion of the overall flow in the stream (i.e., contact water and dewatering water), and thus treatment cannot be expected to result in dramatic improvements in the overall ambient stream water quality. The degree of improvement for in-stream water quality will depend upon the fraction of the overall streamflow composed of treated water at a given location and a given time. A more complete discussion of the predicted effects of treatment on in-stream water quality is provided in Appendix A.

## Section 11

# Schedule

Table 11-1 presents the proposed treatment system type, by mine year, for the periods of the mine life. To defer capital expenditures until after the mine is in operations and actual contact water quality is known with more certainty, during average year condition years during construction and early operations in which the maximum month flow rate is less than 1,000 gpm, excess contact water not used in the ore processing circuit or for other purposes will either be mechanically evaporated or be treated with temporary rented equipment.

Table 11-2 presents the features generating contact water and the type of treatment applied by mine year in the post-closure period. Three water sources are projected to require treatment in perpetuity: (1) Fiddle DRSF toe seepage, (2) Hangar Flats pit lake discharge, and (3) West End pit lake discharge.

**Table 11-1. Proposed Water Treatment Schedule (assuming a 12-year mine operations period) and Treatment System Types**

Treatment Method	Mine Phase and Year																								In Perpetuity
	Construction			Mine Operations												Reclamation					Post-Closure				
	-3	-2	-1	1	2	3	4	5	6	7	8	9	10	11	12	13	14	15	16	17	18	19	20	21-42	
Enhanced Evaporation	-	X	X	X	X	X	X	X	X	X	X	X	X	X	X	X	X	X	X	X	-	-	-	X	X
Membrane and Iron Coprecipitation Technology Confirmation	X	-	-	-	-	-	-	-	-	-	-	-	-	-	-	-	-	-	-	-	-	-	-	-	-
Rented/Temporary Iron Coprecipitation Treatment System	-	X	X	-	-	-	-	-	-	-	-	-	-	-	-	-	-	-	-	-	-	-	-	-	-
Rented/Temporary Membrane Treatment System	-	-	-	X	X	X	-	-	-	-	-	-	-	-	-	-	-	-	-	-	-	-	-	-	X
Centralized Active WTP	-	-	-	-	-	-	X	X	X	X	X	X	X	X	X	X	X	X	X	X	X	X	X	X	X
BCR and Wetland Technology Confirmation Testing	-	-	-	-	-	-	-	-	-	-	X	X	X	X	X	-	-	-	-	-	-	-	-	-	-
Passive Treatment System (TSF Consolidation Waters Only)	-	-	-	-	-	-	-	-	-	-	-	-	-	-	-	-	-	-	-	-	-	-	-	X	-
Passive Treatment System (Fiddle DRSF Toe Seepage Only)	-	-	-	-	-	-	-	-	-	-	-	-	-	-	-	X	X	X	X	X	X	X	X	X	X
Sanitary WWTP	-	X	X	X	X	X	X	X	X	X	X	X	X	X	X	X	X	X	X	X	-	-	-	-	-

*Abbreviations:*

*BCR = biochemical reactor*

*DRSF = development rock storage facility*

*TSF = tailings storage facility*

*WTP = water treatment plant*

*WWTP = wastewater treatment plant*



**Table 11-2. Post-Closure Water Treatment Schedule (assuming a 12-year mine operations period)**

Water Source	Mine Phase and Year																											In Perpetuity 43+						
	Reclamation					Post-Closure																												
	13	14	15	16	17	18	19	20	21	22	23	24	25	26	27	28	29	30	31	32	33	34	35	36	37	38	39		40	41	42			
Yellow Pine Pit Dewatering (Active WTP)	X	X	X	-	-	-	-	-	-	-	-	-	-	-	-	-	-	-	-	-	-	-	-	-	-	-	-	-	-	-	-	-	-	-
TSF Runoff (Evaporation)	X	X	X	X	-	-	-	-	-	-	-	-	-	-	-	-	-	-	-	-	-	-	-	-	-	-	-	-	-	-	-	-	-	
TSF Runoff (Active WTP)	X	X	X	X	X	X	X	X	-	-	-	-	-	-	-	-	-	-	-	-	-	-	-	-	-	-	-	-	-	-	-	-	-	
TSF Runoff (Passive Treatment)	-	-	-	-	-	-	-	-	X	X	X	X	X	X	X	X	X	X	X	X	X	X	X	X	X	X	X	X	X	X	X	X	X	
Fiddle DRSF Toe Seepage (Passive Treatment)	X	X	X	X	X	X	X	X	X	X	X	X	X	X	X	X	X	X	X	X	X	X	X	X	X	X	X	X	X	X	X	X	X	
Hangar Flats Pit Lake Discharge (Active WTP)	X	X	X	X	X	X	X	X	X	X	X	X	X	X	X	X	X	X	X	X	X	X	X	X	X	X	X	X	X	X	X	X	X	
West End Pit Lake Discharge (Evaporation, Temporary Treatment System)	-	-	-	-	-	-	-	-	-	-	-	-	-	-	-	-	-	-	-	-	-	-	-	-	-	-	-	-	-	-	-	-	-	

Abbreviations:

DRSF = development rock storage facility

TSF = tailings storage facility

WTP = water treatment plant



## Section 12

# Conclusions

This Plan has been developed using the best available information and standard engineering practices. It is focused on ensuring that mine-impacted water will be discharged to WOTUS only if it meets IPDES permit limits and will not lead to a degradation of baseline water quality conditions at the Project site. Specifically, this Plan (including the associated updated geochemical modeling):

- Is based upon extensive scientific information, including long-term baseline monitoring, detailed hydrologic and geochemical modeling, and other analyses.
- Addresses water quality management during all phases of the SGP, from construction through post-closure.
- Assesses a series of proven treatment technology options and selected those most suitable for the SGP.
- Predicts that, during operations and post-closure, water quality in Meadow Creek and EFSFSR will be improved compared to baseline conditions, with arsenic and antimony generally in the range of the baseline minimum to average concentrations. The degree of improvement for any given location along the streams will depend, at least in part, on the proportion of treated water discharge to the ambient stream flow at that location.
- Predicts that antimony and mercury concentrations will not see the same degree of change as arsenic because antimony in the contact water and dewatering water is not expected to be substantially higher than anticipated permit limits, and mercury in the EFSFSR system upstream of Sugar Creek is already below the most stringent Idaho criterion and water treatment will maintain that condition.
- Can be modified to function with any of the alternatives being evaluated for the DEIS. Treatment of the Hangar Flats pit lake water in Alternatives 1, 3, and 4 would require a WTP with larger flow capacity.
- Offers assurance that Midas Gold can operate the SGP in compliance with provisions of the Clean Water Act.

## Section 13

# References

- Brown and Caldwell (BC), 2017. *Stibnite Gold Project: Water Resources Summary Report*, Prepared for Midas Gold, June.
- BC, 2018a. *Final Stibnite Gold Project Site-Wide Water Balance Proposed Action Report*, Prepared for Midas Gold, June.
- BC, 2018b. *Final Stibnite Gold Project Hydrologic Model Proposed Action Report*, Prepared for Midas Gold, October.
- BC, 2018c. *Draft SGP Water Management Narrative*, Prepared for Midas Gold, June.
- BC, 2018d. *Final Stibnite Gold Project Stream and Pit Lake Network Temperature Model Existing Conditions Report*, Prepared for Midas Gold, March.
- BC, 2019a. *SGP EIS Modified Proposed Action Chapter 2 Technical Memorandum*, Prepared for Midas Gold, May.
- BC, 2019b. *Final Modified PRO Alternative Modeling Report*, Prepared for Midas Gold, September.
- Butler, B. A., M. E. Smith, D. J. Reisman, and J. M. Lazorchak, 2010. *Metal removal efficiency and ecotoxicological assessment of field-scale passive treatment biochemical reactors*.
- Cassie, D., 2006. *The thermal regime of rivers: a review*, *Freshwater Biology* 51:1389-1406.
- Crites, Ronald, E Joe Middlebrooks, Robert K Bastian, and Sherwood C Reed, 2014. *Natural Wastewater Treatment Systems*, Second Edition.
- Higgins, T., C. Yeager, D. Fink, and K. Jenkins, 2013. *Meeting part-per-trillion mercury limits for power Plant wastewater*, 74th Annual International Water Conference, IWC 13-43.
- Etheridge, A.B., 2015, *Occurrence and transport of selected constituents in streams near the Stibnite Mining Area, central Idaho, 2012-2014*: U.S. Geological Survey Scientific Report 2015-5166, 47p., accessed at: <http://dx.doi.org/10.3133/20155166>.
- Ferguson, K. D., and S. M. Leask, 1988. *The Export of Nutrients from Surface Coal Mines*, Environment Canada Regional Program Report 87-12.
- Goetz, F. 1989. *Biology of the bull trout, Salvelinus confluentus, a literature review*. Willamette National Forest, Eugene, Oregon, February 1989. 53 pp.
- HDR Engineering Inc., 2017. *Final Surface Water Quality Baseline Study*, Prepared for Midas Gold, December 2016. Revised May 2017.
- Higgins, T., C. Yeager, D. Fink, and K. Jenkins, 2013. *Meeting part-per-trillion mercury limits for power Plant wastewater*. 74th Annual International Water Conference, IWC 13-43.
- Idaho Administrative Procedures Act (IDAPA), 2017. *Water Quality Standards, Surface Water*.
- Inoue, Y., and M. Munemori, 1979. *Coprecipitation of mercury (II) with iron (III) hydroxide*. *Environ. Sci. Technol.* 13:443-445.
- Inoue, Y., and M. Munemori, 1980. *The coprecipitation of antimony (III or V) with iron (III) hydroxide*. *Bull. Chem. Soc. Jpn.* 53:926-929.
- Jackson, C. K., I. Koch, and K. J. Reimer, 2013. *Mechanisms of dissolved arsenic removal by biochemical reactors: a bench- and field-scale study*.

- Janin, A., I. Ness, and S. Wilbur, 2015. *Arsenic, antimony and selenium removal from mine water by anaerobic bioreactors at laboratory scale*.
- McPhail, J.D., and C.B. Murray. 1979. *The early life-history and ecology of dolly varden (Salvelinus Malma) in the upper Arrow Lakes*. Department of Zoology, Institute of Animal Resource Ecology, Fort Steele, British Columbia, December 1979. 113 pp.
- McCullough, D.A., S. Spalding, D. Sturdevant, and M. Hicks. 2001. *Issue paper 5: Summary of technical literature examining the physiological effects of temperature on salmonids*. EPA-910-D-01-005. U.S. Environmental Protection Agency, Region 10, Seattle, Washington. 114 p.
- Midas Gold, 2016. *Plan of Restoration and Operations*, Stibnite Gold Project, September.
- Midas Gold, 2019. *Water Quality Summary Report 2012-2017*, Stibnite Gold Project, February.
- Negri, M. C., P. S. Gillenwater, and M. Urgun-Demirtas, 2011. *Emerging technologies and approaches to minimize discharges into Lake Michigan*. Phase 2 Module 3 Report. ANL-11/13. Argonne National Laboratory, Lemont, IL., April 19.
- Nucon (not dated). *Mercury removal case studies*. Accessed at: <http://www.nucon-int.com/mercury-removal-case-studies> in January 2020.
- Rio Applied Science & Engineering, 2019. *Stream Design Report*, Prepared for Midas Gold, Inc., February.
- ROCHEM, 2019. *Leachate management challenges*. Presentation to Michigan Department of Environment, Great Lakes and Energy (EGLE). Accessed at: [https://www.michigan.gov/documents/egle/tou-2019UPSWF-Presentation-LeachateManagement\\_654249\\_7.pdf](https://www.michigan.gov/documents/egle/tou-2019UPSWF-Presentation-LeachateManagement_654249_7.pdf) in January 2020.
- Sato, Y., M. Kang, T. Kamei, and Y. Magara, 2002. *Performance of nanofiltration for arsenic removal*, Water Res.
- SRK Consulting, Inc. (SRK), 2018. *Stibnite Gold Project Proposed Action Site-Wide Water Chemistry (SWWC) Modeling Report*, December. Revised September 13, 2019.
- Tetra Tech, 2019, *Final Conceptual Stream and Wetland Mitigation Plan (CMP)*, Stibnite Gold Project, Valley County, Idaho, U.S. Army Corps of Engineers File Number: NWW-2013-0321m March.
- Twidwell, L., 2011. *The removal of arsenic, selenium and metals from aqueous solution by iron precipitation and reduction techniques*. In: Camp, 2011. The Minerals, Metals & Materials Society TMS 2011 Annual Meeting, San Diego, CA.

# Appendix A: SRK Consulting Stibnite Water Treatment Evaluation

---



## Technical Memorandum

---

<b>To:</b>	Alan Haslam	<b>Date:</b>	March 27, 2020
<b>Company:</b>	Midas Gold Idaho, Inc.	<b>From:</b>	Michael Herrell
<b>Copy to:</b>	Gene Bosley, Austin Zinsser, John Meyer (Midas Gold) Doug Durbin, Jeremy Aulbach, Dan Stanaway, Kristan Robbins, Todd Glindeman (Brown and Caldwell) Amy Prestia (SRK)	<b>Reviewed by:</b>	Rob Bowell
<b>Subject:</b>	Stibnite – Water Treatment Evaluation	<b>Project #:</b>	200900.090

---

### 1. Introduction

Midas Gold Idaho, Inc. (Midas Gold) submitted a plan of operations for mining on National Forest System (NFS) lands, titled *Stibnite Gold Project (SGP or Project) Plan of Restoration and Operations (PRO)* to the United States Forest Service (USFS) in September 2016, in accordance with USFS regulations for locatable minerals set forth at 36 Code of Federal Regulations 228 Subpart A. Subsequent to submission of the PRO, Midas Gold continued to refine and improve the Project design and components to further reduce environmental impact. The refinement of the PRO has resulted in more detailed analyses and reevaluation of the Project components to explore how they might be modified to further avoid and minimize environmental impacts, meet the Project purpose and need, and result in a better Project overall. Midas Gold's continued analysis of the potential effect of the Project on the impact footprint and key resources such as wetlands and streams, water quality, federally listed species, public use, and other environmental considerations pointed to areas in which the Project's environmental performance might be improved through modifications of the PRO. Revisions to the PRO mine design and operation are collectively referred to as the Modified PRO (ModPRO).

On behalf of Midas Gold, SRK Consulting (U.S.) Inc. (SRK) conducted geochemical modeling to determine the potential for groundwater and surface water impacts from the proposed open pits, development rock storage facilities (DRSFs), and tailings storage facility (TSF) for SGP variations as described in the PRO (Midas Gold 2016) and the ModPRO (Brown and Caldwell 2019b). The water quality predictions developed to support the PRO (SRK 2018) and the ModPRO were reviewed by the USFS and are being considered (for each alternative) in the environmental effects analysis portion of the Draft Environmental Impact Statement (DEIS) for the Project. The water quality predictions used to analyze the PRO and ModPRO did not explicitly consider treatment of site contact water. The provided models assumed that site contact water would be managed but it was not carried forward into the downstream predictions as treatment targets had not yet been established.

Midas Gold has now established an objective for its SGP of improving water quality in the Stibnite Mining District ("District") versus the currently impaired water quality for the District. This is an iterative process of defining existing (impaired) conditions, modeling potential impacts related to the SGP, modeling potential mitigations to such impacts and the effectiveness thereof, modeling the benefits of addressing various legacy

impacts (for example removal of sources such as the Bradley tailings), and modeling the benefits of potential active and passive water treatment options.

The initial geochemical evaluation of treatment options is presented in this report. Additional water quality modeling continues as the Project continues to be refined to meet Midas Gold's objective of an overall improvement in water quality for the District. Generally, as detailed in this report, Midas Gold's objective is shown as being achievable. However, Midas Gold continues to evaluate opportunities to further improve water quality and such opportunities will be modelled and detailed in subsequent reports.

Midas Gold proceeded with the development of a Plan that considers treatment of site discharges during all phases of Project development including construction, operations, reclamation, and post-closure. The Plan includes an evaluation of potential water treatment technologies, an evaluation of the performance and effectiveness of proposed water treatment methods, and a description of how proposed water treatment would be applied to achieve compliance with water quality standards. The purpose of the Plan is to demonstrate the applicability, practicability, and efficacy of proposed water treatment methods to further improve surface water quality in Meadow Creek and the East Fork of the South Fork of the Salmon River (EFSFSR).

The SGP Plan considers active and in post closure, potentially, passive treatment of the following discharges:

- Construction – treatment of contact water runoff from (1) legacy features undergoing removal and repurposing/incorporation into the TSF embankment (i.e., Hecla Heap, SODA), (2) the TSF embankment/starter dam footprint, and, (3) the Yellow Pine pit lake;
- Operations – site contact water not used in ore processing, mine drainage, and groundwater produced from pit dewatering destined for reintroduction to the groundwater aquifer via the Rapid Infiltration Basins (RIBs);
- Reclamation – treatment of Fiddle Development Rock Storage Facility (DRSF) toe seepage by potentially passive treatment methods; and
- Post Closure – tailings consolidation water, groundwater pumped to the RIBs, discharges from the Hangar Flats and West End pit lakes and toe seepage from the Fiddle DRSF.

To evaluate the extent of improvement to the overall water quality within the EFSFSR drainage (upstream of the Sugar Creek confluence) when effluent is treated to the targets indicated in the Plan, SRK updated the ModPRO site wide water chemistry (SWWC) model to account for treatment of the discharges indicated above for the various phases of mine life. This memorandum provides a summary of the surface water quality model updates and model results in the EFSFSR. These updated analyses are compared to the ModPRO water quality predictions, which we reiterate, *do not* fully incorporate the effects of water treatment. The ModPRO SWWC predictions indicate that contact water and mine drainage could exhibit concentrations of arsenic, antimony, and mercury that may require treatment during operations and in post-closure to meet applicable Idaho Water Quality criteria and be consistent with aspects of the Clean Water Act. Therefore, the treatment analysis included in the Plan and discussed in this memorandum focuses on these three parameters.

## 2. Model Updates

The SWWC model (SRK 2018) developed as part of the ModPRO was updated for this evaluation. Details of the model setup, inputs and assumptions are provided in SRK (2018). Subsequent modifications made as part of the ModPRO water quality evaluation are documented in Brown and Caldwell (2019b). The following subsections provide a summary of the modifications made to the SWWC as part of the current evaluation.

## 2.1. Treatment Water Quantity and Quality

In the ModPRO model, site contact water (e.g., pit wall runoff, DRSF toe seepage, etc.), and mine drainage were assumed to be managed internally. Management of this water included reclaim for use in ore processing and treatment of excess water requiring discharge. However, as a plan for treatment was not provided in detail and predictive constituent concentrations in the effluent were not yet developed, the treated discharge was not included for the ModPRO. That is, no load associated with effluent (meeting treatment standards, but having non-zero concentrations of constituents of concern) was added in the ModPRO SWWC model. For this treatment evaluation, a treated effluent was added to the SWWC near the confluence of Garnet Creek and the EFSFSR (i.e., near YP-SR-10), the approximate proposed location of the water treatment plant outfall. The load was estimated based on anticipated average annual contact water treatment volumes (Table 1), RIB infiltration water treatment volumes (Table 2) and proposed target treatment concentrations (Table 3).

*Table 1. Proposed Site Contact Water Treatment Volumes*

Mine Year	Maximum Monthly Flow (gpm)	Annual Average Flow (gpm)
1	0	0
2	0	0
3	250	146
4	500	321
5	900	388
6	1,100	460
7	2,000	567
8	1,400	457
9	1,400	411
10	1,550	454
11	1,100	355
12	1,100	681

Note: values provided by Brown and Caldwell (2020a, pers. comm.)

*Table 2. Predicted RIB Infiltration Volumes recharging Meadow Creek and EFSFSR valley alluvium*

Period	Mine Year	RIB Infiltration Volume (cfs)		
		YP-T-22	YP-SR-10	YP-SR-8
Operations	1	0.06	0.91	0.03
	2	0.06	0.97	0.03
	3	0.06	0.84	0.03
	4	0.06	0.97	0.03
	5	0.10	1.54	0.05
	6	0.11	1.68	0.05
	7	0.25	4.10	0.13
	8	0.31	4.99	0.16
	9	0.21	3.21	0.11
	10	0.16	2.55	0.08
	11	0.17	2.68	0.09
	12	0.26	4.21	0.14
Post Closure	1	0.04	0.23	0
	2	0.08	0.41	0

*Table 3. Proposed Treated Effluent Targets*

Parameter	Treated Target Concentration (mg/L)
Arsenic	0.010
Antimony	0.0052
Mercury	1.20E-05

Note: values provided by Brown and Caldwell (2020b, pers. comm.)

During operations, the SWWC model predicts parameter concentrations on an annual timestep. Therefore, the annual average flows presented in Table 1 were used to calculate treated effluent loadings in the SWWC model. Concentrations of arsenic, antimony, and mercury were set at the treatment targets provided in Table 3. In the ModPRO, influent chemistry to the treatment plant was not estimated. It is possible that influent chemistries may be lower than the treatment targets. However, in the absence of influent predictions, it was assumed that all treated water would be discharged at the target treatment concentrations during operations.

During operations, and during the first two years of closure, groundwater pumped from dewatering wells that is not reclaimed for mine use (e.g., ore processing) will be directed to the RIBs. For this treatment evaluation, it was assumed that all water pumped to the RIBs will be treated. In the model water reporting to the RIBs was set to the minimum of the modeled concentration or the target treatment concentration (Table 3). Predicted RIB infiltration volumes reporting to Meadow Creek and the EFSFSR are provided in Table 2.

During post-closure, the concentration of treated discharges was set to the minimum of the modeled concentration or the target treatment concentrations (Table 3).

## 2.2. Streamflow Reductions Related to Groundwater Interactions During Mining

During operations, dewatering, and mining of the open pits will cause a small amount of surface water to recharge groundwater. The load lost with this advective flux from surface water to groundwater was not included in the ModPRO (i.e., surface to groundwater load was not removed from Meadow Creek or the EFSFSR). This results potentially in a double counting of load since this surface water loss is re-introduced into Meadow Creek and the EFSFSR via the RIBs. For the current evaluation, a load reduction to account for surface and groundwater interactions was calculated as follows:

- 1) Estimate changes in groundwater-stream interactions;
- 2) Assign a water quality to the water lost to groundwater from surface water; and
- 3) Calculate the load removed from the stream as the product of the rate of surface to groundwater flow and the assigned water quality.

The predicted average annual streamflow reductions due to simulated changes in groundwater-stream interactions are provided in Table 4. These reductions include both predicted decreases in groundwater discharge to streams and predicted additional stream losses to groundwater. Constituent concentrations for groundwater in the alluvium near Hangar Flats and Yellow Pine pits (SRK 2018) were used to estimate the load lost from the streams.

Table 4. Predicted Streamflow Reductions Related to Groundwater Interactions during Mining

Mine Year		Streamflow Loss (cfs)		
		YP-T-27 to YP-T-22	YP-T-22 to YP-SR-8	YP-SR-6 to YP-SR-4
Operations	1	0	0	2.3
	2	0	0	1.7
	3	0	0	2.1
	4	0	0	2.0
	5	0	0	2.0
	6	0	0	2.1
	7	0.45	0.34	2.2
	8	0.46	0.88	2.0
	9	0.45	1.0	1.9
	10	0.38	1.0	1.6
	11	0.46	0.98	1.9
	12	0.58	0.94	2.2
Post-closure	1	0.20	No loss	0.88
	2	0.18	No loss	0.19

Note: values provided by Brown and Caldwell (2020c, pers. comm.)

### 3. Model Results

Treatment of the mine discharge sources listed in Section 1 will change water quality at the following model nodes:

- Operations
  - EFSFSR: YP-SR-10, YP-SR-8, YP-SR-6, YP-SR-4 and YP-SR-2
- Closure
  - Meadow Creek: YP-T-22
  - EFSFSR: YP-SR-10, YP-SR-8, YP-SR-6, YP-SR-4 and YP-SR-2
  - Fiddle Creek: YP-T-11
  - West End Creek: YP-T-6
  - Sugar Creek: YP-T-1

Predicted water qualities were developed at all nodes in the ModPRO that will change from implementing water treatment. However, only the results of nodes immediately downstream of a treated source are discussed in detail in this memo. Nodes where there is no change to the water quality predictions relative to the ModPRO are also not included (i.e., YP-T-27 and YP-T-1). Results from all other locations are presented in Attachment A.

In addition, to the nodes immediately downstream of a treated source, the influence of treatment on downstream water quality is also evaluated at the following nodes in the model:

- YP-SR-4 – EFSFSR upstream of the confluence with Sugar Creek

- YP-SR-2 – EFSFSR downstream of the confluence with Sugar Creek

These locations were selected because YP-SR-4 is downstream of all sources anticipated to be treated in the EFSFSR, and YP-SR-2 (the downstream node for the SWWC model) is downstream of all anticipated treated sources and the additional input from Sugar Creek. Predicted concentrations of arsenic, antimony, and mercury during operations and post-closure are provided in Attachment A.

Changes in concentrations from treating the site discharges are evaluated relative to the ModPRO predictions, baseline concentrations, and the most stringent potentially applicable surface water standard. Results plots showing these comparisons are provided in Attachment A. The figures in Attachment A were constructed to convey several pieces of information on the projected in-stream water quality associated with the SGP. First, they compare the projected water quality conditions under the ModPRO scenario without consideration of water quality management with the projected ModPRO conditions assuming water treatment is provided. Second, they illustrate where the simulated constituent concentrations fall with respect to the most stringent of the Idaho surface water quality criteria, and third, they reflect where the projected concentrations fall relative to measured baseline water quality conditions at the same locations on the streams as the modeled nodes.

A second set of figures comparing the results to the Idaho Numeric Surface Water Human Health Criteria and the Idaho Numeric Surface Water Criteria for Cold Water Biota were also developed to highlight where model predictions above the most stringent standard (generally human health criteria) are relative to other standards (e.g., aquatic life use). These figures are provided in Attachment B. The attachment B figures are provided separately since, in some cases, the vertical axis scales needed to be adjusted to include all the standards. This results in a smaller visual difference than in the Attachment A figures between the without treatment and with treatment concentrations on the plots, but the mathematical differences at some stream nodes are substantial and indicate that meaningful improvement in water quality can be expected through the implementation of a water treatment program by Midas Gold.

The benefits of treating site contact and RIB water are evidenced in the predicted arsenic concentrations at YP-SR-4. Arsenic concentrations at this location are predicted to decrease relative to the ModPRO during operations (Figure 1) and in post-closure (Figure 2). Predicted arsenic concentrations are also less than concentrations observed under existing conditions with most of the predicted monthly concentrations being less than the average concentration under existing conditions.

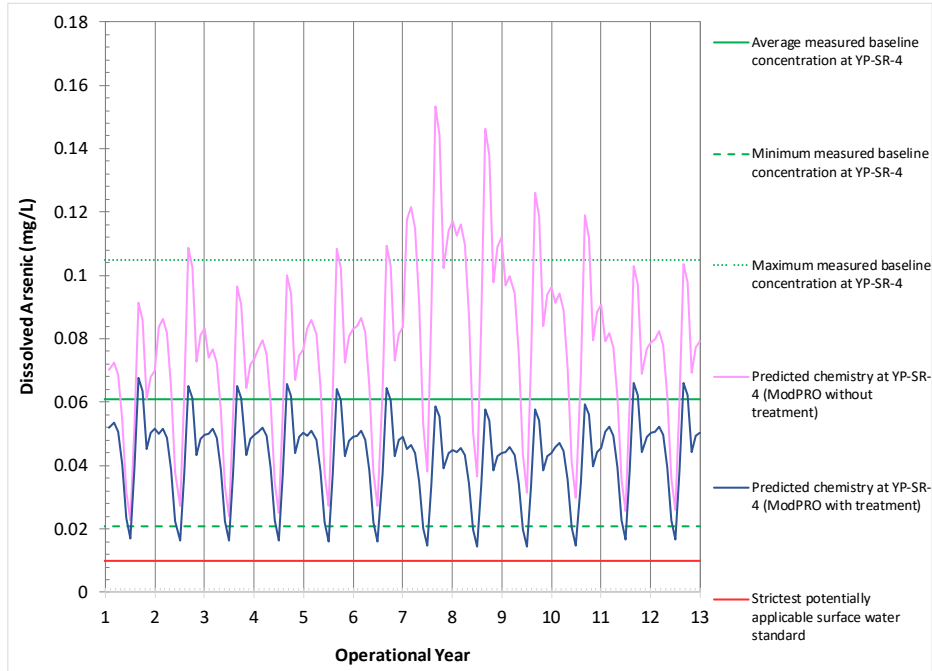

Figure 1. Predicted Arsenic Concentrations during Operations at Node YP-SR-4 – Treatment Evaluation Scenario

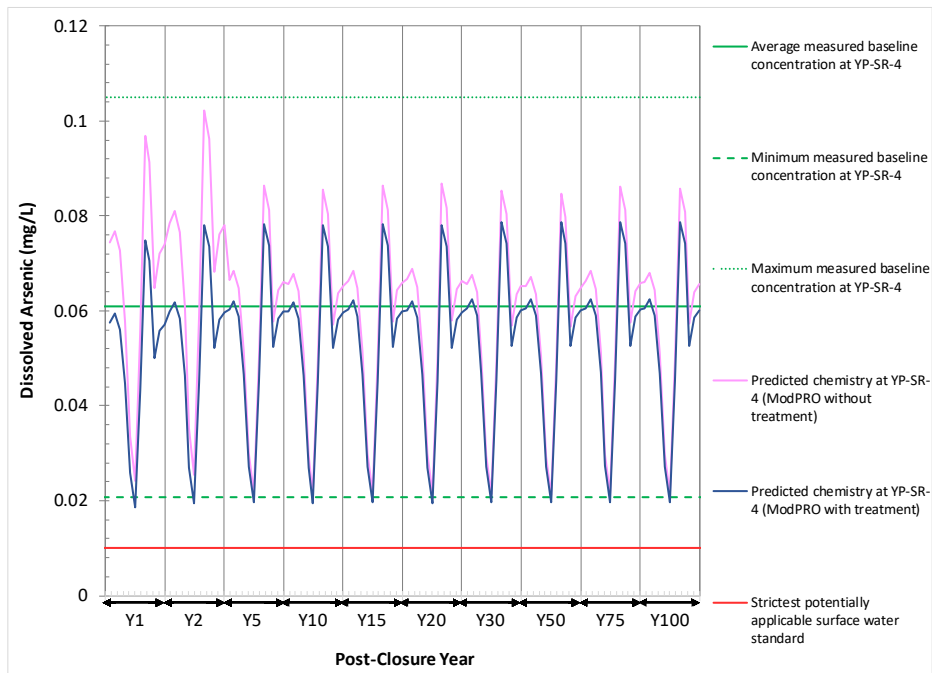

Figure 2. Predicted Arsenic Concentrations during Post Closure at Node YP-SR-4 – Treatment Evaluation Scenario

Predicted concentrations of other parameters at other model locations during operations and post-closure are provided in the following subsections.

### 3.1. During Operations (with water treatment)

- YP-SR-10
  - Predicted instream arsenic concentrations at YP-SR-10 are less than the predicted ModPRO (without treatment) concentrations and are consistently less than the average baseline concentration measured at this location (Figure A-1).
  - Predicted instream antimony concentrations at YP-SR-10 are only slightly less than the ModPRO (without treatment) predicted concentrations in the first six years of operations. This occurs because antimony concentrations in water directed to the RIBs from pit dewatering in the ModPRO are only slightly higher than the treatment target. Antimony concentrations increase in the ModPRO (without treatment) in Year 7 of operations when dewatering of the West End Pit occurs, resulting in a larger decrease in predicted antimony concentrations in the treatment scenario relative to the ModPRO (without treatment), as a result of a larger amount of antimony being removed in the treatment plant (Figure A-2).
  - Mercury concentrations at YP-SR-10 are predicted to be higher in comparison to the ModPRO (without treatment) predictions (Figure A-3). This occurs because, as discussed in Section 2.1, treated effluent was not included in the ModPRO (i.e., there was not treatment flow or load included in the ModPRO model). Inclusion of the treated load results in a minor increase in predicted mercury concentrations.
- YP-SR-4
  - As noted above, arsenic concentrations at YP-SR-4 decrease relative to the ModPRO during operations (Figure 1, Figure A-4). Predicted arsenic concentrations are also less than concentrations observed under existing conditions with most of the predicted monthly concentrations being less than the average concentration under existing conditions.
  - Predicted antimony concentrations at YP-SR-4 decrease relative to the ModPRO (without treatment) predicted concentrations and are less than the maximum existing conditions concentration (Figure A-5). Concentrations are generally below the average annual existing antimony concentration.
  - Mercury concentrations are predicted to increase slightly relative to the ModPRO (without treatment) at YP-SR-4 (Figure A-6). This occurs because, as discussed in Section 2.1, treated effluent was not included in the ModPRO, and additional load at the treated concentrations is added to the system in the current evaluation. The projected RIB mercury input concentrations were less than the treatment target during operations, and, therefore, all input concentrations are the same as in the ModPRO (i.e., using the treated effluent target would increase the RIB discharge mercury concentration). As a result, the addition of the treated effluent load, which wasn't included in the ModPRO (see discussion in Section 2), causes a slight increase in mercury concentrations at YP-SR-4 relative to the ModPRO, but this is a consequence of the ModPRO modeling zeroing-out the effluent load, not an increase in load from the Project.
  - Predicted mercury concentrations at YP-SR-4 (Figure A-6) are predicted to be less than the maximum concentration under existing conditions and well below the strictest potentially applicable surface water quality standard.
- YP-SR-2
  - Arsenic concentrations decrease at YP-SR-2 and are predicted to be less than baseline average annual concentration (Figure A-7).
  - Antimony concentrations are predicted to be less than the ModPRO (without treatment) predicted concentrations at YP-SR-2 and are less than concentrations observed under existing conditions

(Figure A-8). Concentrations are generally below the average annual baseline antimony concentration.

- Like YP-SR-4, mercury concentrations are slightly elevated relative to the ModPRO (without treatment) at YP-SR-2 due to the additional treated effluent load during operations (Figure A-9). As discussed above, this treated load was not included in the ModPRO modeling and has resulted in a small incremental increase in downstream load in the current evaluation. However, concentrations are still predicted to be less than concentrations observed under existing conditions, are generally less than the average annual baseline conditions concentration and are well below the strictest potentially applicable water quality standard.

### 3.2. Post-closure

- YP-T-22 (Meadow Creek)
  - Treatment of Hangar Flats pit discharge results in arsenic concentrations being less than the ModPRO (without treatment) predictions at YP-T-22 (Figure A-10). Concentrations are also predicted to be less than the minimum baseline concentration and the strictest potentially applicable surface water standard.
  - Predicted antimony concentrations at YP-T-22 were less than the proposed treatment target in the ModPRO (without treatment). Therefore, predicted antimony concentrations at YP-T-22 are identical to the predicted ModPRO (without treatment) concentrations (Figure A-11) since, as discussed in Section 2.1, predicted concentrations were used in the model when they were less than the treatment target.
  - Mercury concentrations are predicted to be less than the ModPRO (without treatment) at YP-T-22 once treated water is discharged to Meadow Creek (Figure A-12).
- YP-SR-10 (EFSFSR)
  - Changes in arsenic, antimony and mercury concentrations at YP-SR-10 are the same at YP-T-22. For example, treatment of the TSF consolidation water, RIB infiltration water (during the first 3 years of closure) and the Hangar Flats pit lake discharge results in the following:
    - Decreases in arsenic concentrations relative to the ModPRO (without treatment) predictions (Figure A-13).
    - No visible changes in predicted antimony concentrations relative to the ModPRO (without treatment) predictions (Figure A-14).
    - Decreases in mercury concentrations relative to the ModPRO (without treatment) predictions once discharge from the Hangar Flats pit lake begins (Figure A-15).
- YP-T-11 (Fiddle Creek)
  - Arsenic concentrations are predicted to be less than the ModPRO (without treatment) predictions and the strictest potentially applicable surface water standard at YP-T-11 (Figure A-16).
  - Antimony (Figure A-17) and mercury (Figure A-18) were predicted to be less than the treatment targets and therefore predicted concentrations are identical to the ModPRO (without treatment) predictions at YP-T-11.
- YP-T-6 (West End Creek)
  - Due to the small volume of water discharged from the West End Pit, predicted concentrations of arsenic (Figure A-19), antimony (Figure A-20) and mercury (Figure A-21) are similar to the ModPRO (without treatment) predictions at YP-T-6.

- YP-SR-4
  - As noted above, arsenic concentrations at YP-SR-4 decrease relative to the ModPRO during post-closure (Figure 2, Figure A-22). Predicted arsenic concentrations are also less than concentrations observed under existing conditions with most of the predicted monthly concentrations being less than the average concentration under existing conditions.
  - Antimony concentrations are similar to the ModPRO (without treatment) predictions during post-closure at YP-SR-4 (Figure A-23). This occurs because the only treated discharge that was greater than the antimony treatment target during post-closure was West End pit lake. As the discharge from West End pit does not drain to YP-SR-4, all inputs reporting to this location are the same as the ModPRO, producing similar results.
  - As a result of treating the Hangar Flats pit lake outflows, mercury concentrations are predicted to be lower in comparison to the ModPRO (without treatment) predictions at YP-SR-4 (Figure A-24). Predicted mercury concentrations are generally within the range of existing conditions and are also predicted to be less than the strictest potentially applicable water quality standard.
- YP-SR-2
  - Arsenic concentrations decrease at YP-SR-2 relative to the ModPRO (without treatment) predictions and are generally predicted to be less than average annual concentration (Figure A-25).
  - Similar to YP-SR-4, predicted antimony concentrations are similar to the ModPRO (without treatment) at YP-SR-2 (Figure A-26). Antimony concentrations are reduced by treating West End pit lake outflows; however, the discharge from this facility is too small and infrequent to reduce concentrations further at YP-SR-2. Predicted antimony concentrations are within the range of baseline conditions.
  - Mercury concentrations decrease relative to the ModPRO (without treatment) predictions and are less than concentrations observed under existing conditions at YP-SR-2 (Figure A-27).

#### 4. Other Alternatives

The Alternative 1 and 3 SWWC models indicate that the Hangar Flats Pit Lake water would exceed arsenic and mercury water quality standards during certain years (Table 7-9, SRK 2018; Table D-8, BC 2019a). If either of those alternatives was selected, conceptually the Hangar Flats pit lake water could be pumped to the treatment plant, and then discharged via an outfall near the pit lake to maintain flows in downstream Meadow Creek. Maximum predicted arsenic and mercury concentrations were 0.069 mg/L and 0.00078 mg/L, respectively for Alternative 1 and 1.1 mg/L and 0.000035 mg/L, respectively for Alternative 3. Treatment of these effluent concentrations to the treatment targets of 0.01 mg/L for arsenic and 0.000012 mg/L for mercury would result in a decrease in the total load, and the concentrations of these parameters in Meadow Creek and the EFSFSR, in comparison to the predictions from the SWWC models without treatment. Decreases in concentrations would be less with distance from the Hangar Flats pit lake. While treating this water under Alternatives 1 and 3 is possible, the WQMP does not present the SWWC modeling results for them because subsequent modeling (i.e., Alternative 2) has demonstrated that routing Meadow Creek around the Hangar Flats provides the following environmental benefits:

- Streamflow is maintained in Meadow Creek;
- Arsenic and mercury concentrations were lower in Meadow Creek and the EFSFSR in comparison to Alternatives 1 and 3, even in the absence of water treatment.

Therefore, water quality predictions were provided for Alternative 2 as part of the WQMP because it results in acceptable water quality in Meadow Creek and the EFSFSR for a treatment plant design that is most practicable.

## 5. Summary

Midas Gold anticipates treating mine-impacted water (contact water, mine drainage) that is to be discharged to surface waters during operations and in post-closure to meet IPDES permit limits and prevent degradation of surface water quality in Meadow Creek and the EFSFSR. The water quality predictions developed as part of the treatment evaluation indicate that concentrations of arsenic, antimony, and mercury would decrease relative to the ModPRO (without treatment predictions). However, there are instances when predicted concentrations do not decrease, they are either very similar (antimony at YP-SR-4) or very slightly above the ModPRO (without treatment) predictions but still below water quality criteria. This can occur because the predicted ModPRO (without treatment) predictions are less than the proposed treatment water quality targets, or as discussed in Section 2.1, as a result of including the treated effluent load, which was not included in the ModPRO water quality predictions.

However, the majority of the predicted concentrations are within the range of existing conditions and several show an overall improvement relative to existing conditions. Predicted arsenic concentrations decrease more than antimony and mercury, relative to the ModPRO (without treatment) predictions, at several locations in the treatment scenario. This occurs because predicted antimony and mercury concentrations are less than or are similar to the treatment targets in several of the effluent sources.

Overall, the comparison of the ModPRO scenario with and without treatment indicates that, for all nodes lying downstream an input of treated water, water quality conditions are improved as a result of the treatment. In some cases, the degree of improvement indicated is small because the proportion of treated water in the stream is small compared with the ambient flow and its constituent load.

The comparison with the Idaho surface water criteria indicates that constituent levels for some parameters at some stream locations would still be above the most stringent criteria (generally human health criteria) but would also be far below Idaho's criteria adopted to protect other beneficial uses (i.e., aquatic life use). While all applicable criteria are important to consider, the fact that the biological uses are protected (and even better protected under the treatment scenario) is also an important consideration.

Finally, the comparison of the projected treated and untreated mine water with the measured baseline concentrations forecasts that water treatment would reduce constituent levels downstream of treated water inputs to concentrations farther below the average baseline levels than for the untreated ModPRO scenario. For some constituents at some nodes, water treatment is even projected to reduce in-stream concentrations to levels below the minimum concentrations observed during the baseline period.

It is important to note that SRK believes that the current models are anticipated to overpredict concentrations of arsenic and antimony as a result of maintaining the existing conditions SWWC model calibration factors during operations and post-closure. Details on the derivation of the calibration factors are provided in SRK (2018). These calibration factors were added to account for non-point discharge loads (e.g., groundwater) that could not be accounted for in the source term inputs at the time of development of the SWWC. A component of the non-point discharge loads originates from mine impacted areas under existing conditions (such as SODA and Hecla Heap). Midas Gold proposes to remove these facilities during operations which will remove load from the system, and potentially reduce constituent concentrations in dewatering water planned to be treated. Since the calibration factors for the non-point discharge loads are not adjusted in the operations and post-

closure water quality predictions, the effect of removing these facilities on surface water quality is not fully accounted for in the modeling. Conceptually, reclamation of these facilities will result in additional improvement in downstream water quality beyond what can currently be predicted in the SWWC model.

## 6. Closing

We trust this memorandum satisfies your current requirement. Should you have any questions or require additional information, please do not hesitate to contact the undersigned.

*This signature was scanned  
with the author's approval  
for exclusive use in this  
document, any other use is  
not authorized.*

---

Michael Herrell, MSc, PGeo (BC, NT)  
Principal Consultant (Geochemistry)  
reviewed by

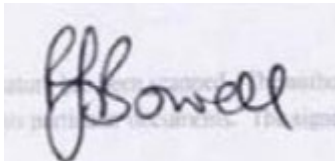
A rectangular box containing a handwritten signature in black ink. The signature appears to be 'Rob Bowell' written in a cursive, slightly stylized font.

---

Rob Bowell PhD CChem CGeol Eur.Geol  
Corporate Consultant (Geochemistry)

## References

- Brown and Caldwell (BC), 2019a. Stibnite Gold Project East Fork South Fork Salmon River TSF/DRSF Alternative Modeling Report, Final, Prepared for Midas Gold Idaho, Inc., August.
- BC, 2019b. Stibnite Gold Project Modified PRO Alternative Modeling Report, Final, Prepared for Midas Gold Idaho, Inc., November.
- BC, 2019c. Stibnite Gold Project Hydrologic Model Sensitivity Analysis, Prepared for Midas Gold, December.
- BC, 2020a. Personal communication. Email from Jeremy Aulbach to Michael Herrell (SRK) RE: IMPORTANT – SWWC Mod PRO with water treatment. January 24, 2020.
- BC, 2020b. Personal communication. Email from Jeremy Aulbach to Michael Herrell (SRK) RE: Stibnite – Treatment Analysis Arsenic Results. January 30, 2020.
- BC, 2020c. Personal communication. Email from Kurt Zeiler to Michael Herrell (SRK) RE: Midas – Hydro Model simulated GW-SW interaction difference spreadsheets. January 31, 2020.
- Midas Gold, 2016. *Stibnite Gold Project (SGP) Plan of Restoration and Operations*.
- SRK, 2018. *Stibnite Gold Project Proposed Action Site-Wide Water Chemistry (SWWC) Modeling Report*. Prepared for Midas Gold, December. Revised September 13, 2019.

# Attachment A

---

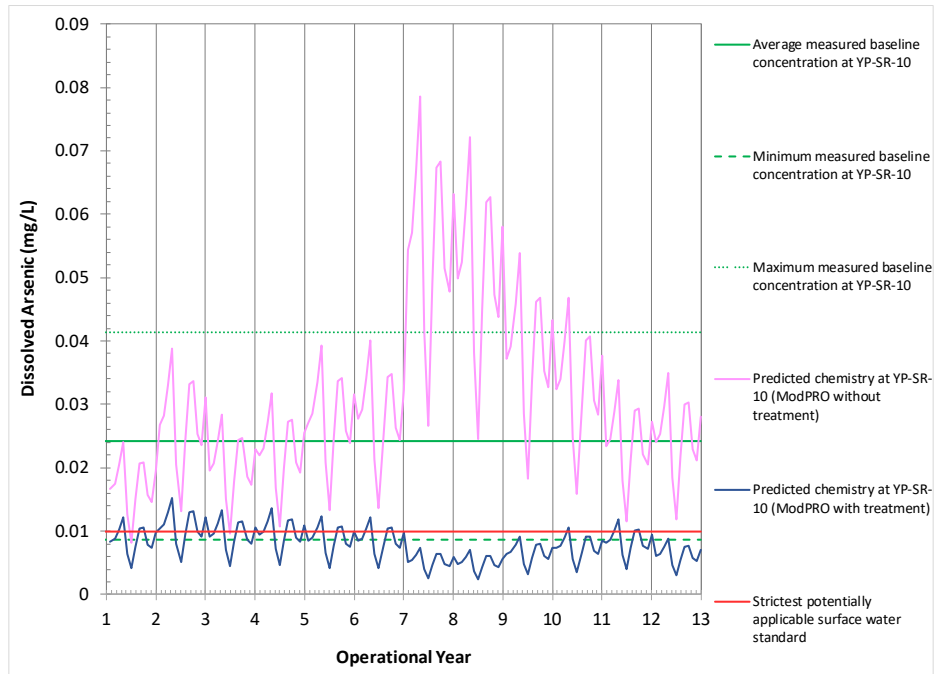

Figure A-1: Predicted Arsenic Concentrations during Operations at Node YP-SR-10 – Treatment Evaluation Scenario

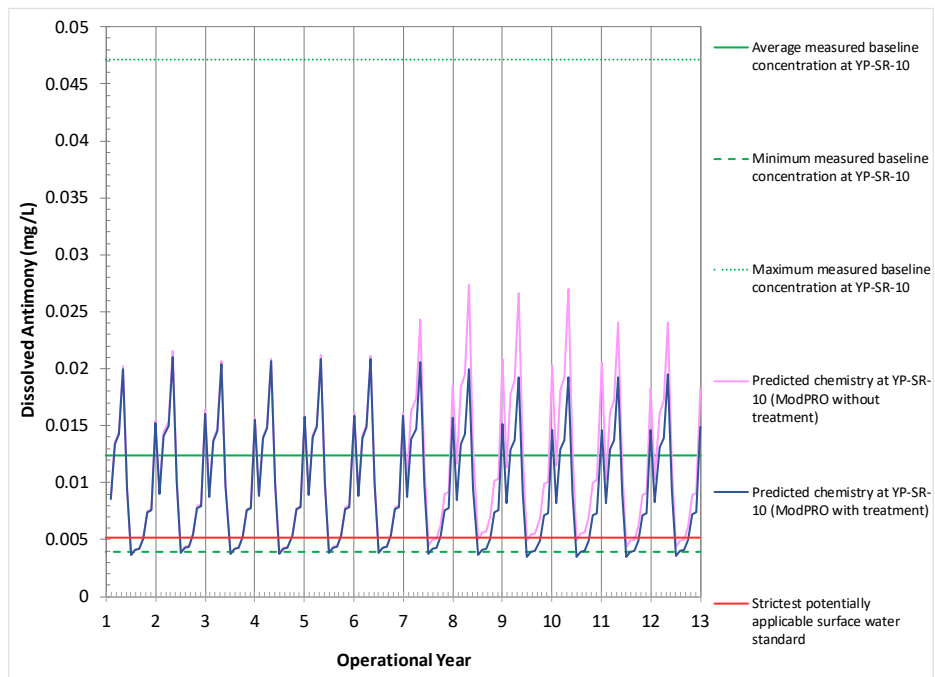

Figure A-2: Predicted Antimony Concentrations during Operations at Node YP-SR-10 – Treatment Evaluation Scenario

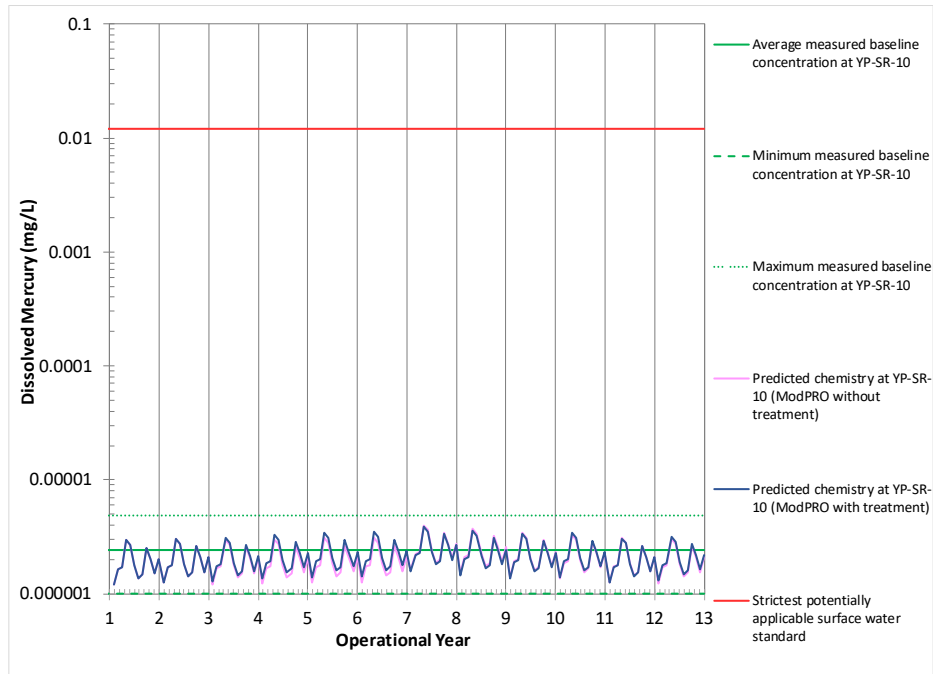

Figure A-3: Predicted Mercury Concentrations during Operations at Node YP-SR-10 – Treatment Evaluation Scenario

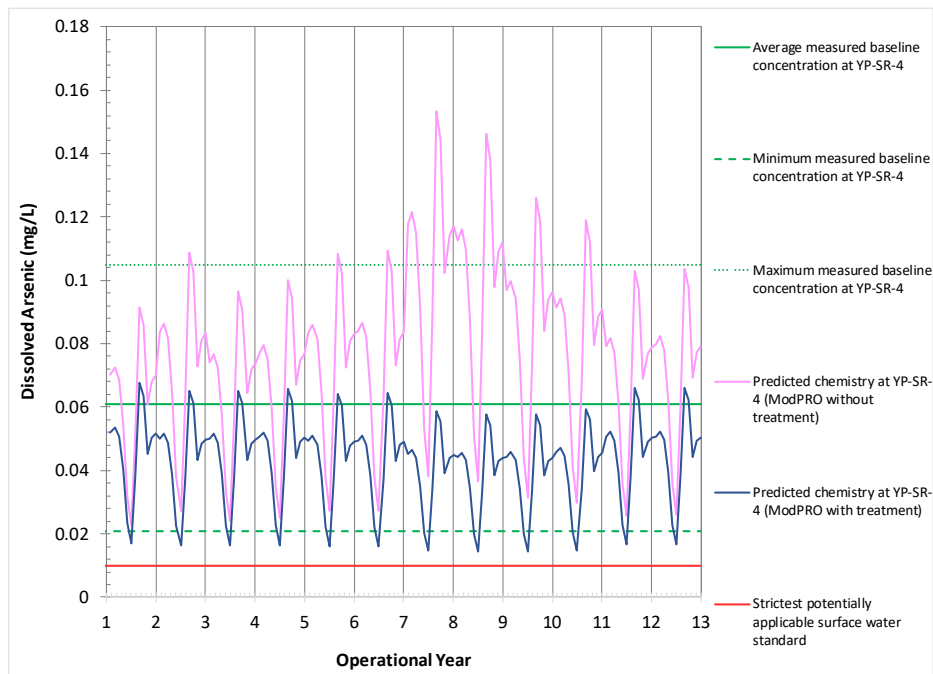

Figure A-4: Predicted Arsenic Concentrations during Operations at Node YP-SR-4 – Treatment Evaluation Scenario

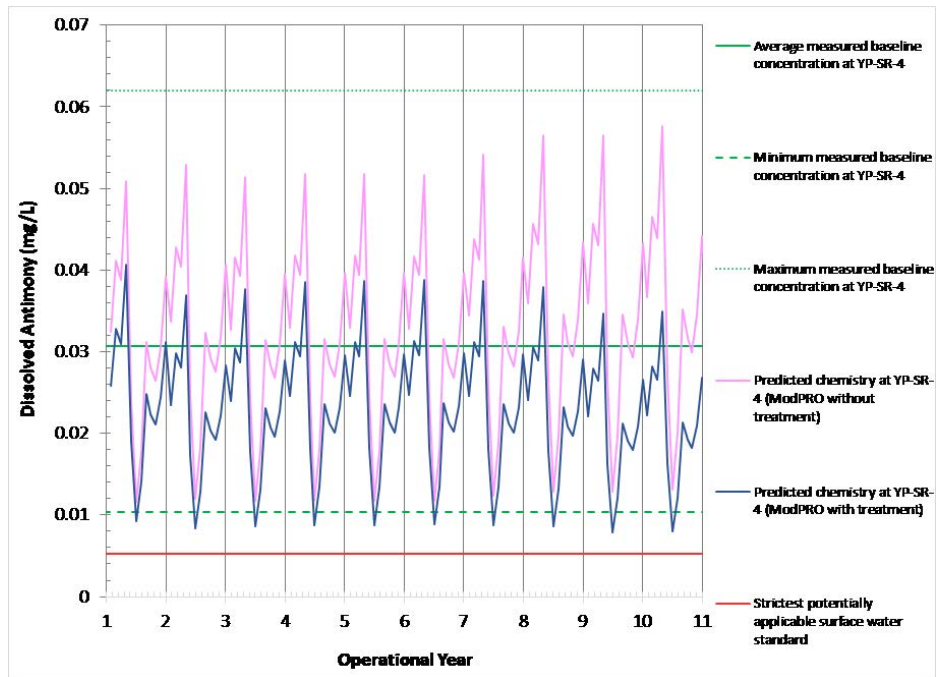

Figure A-5: Predicted Antimony Concentrations during Operations at Node YP-SR-4 – Treatment Evaluation Scenario

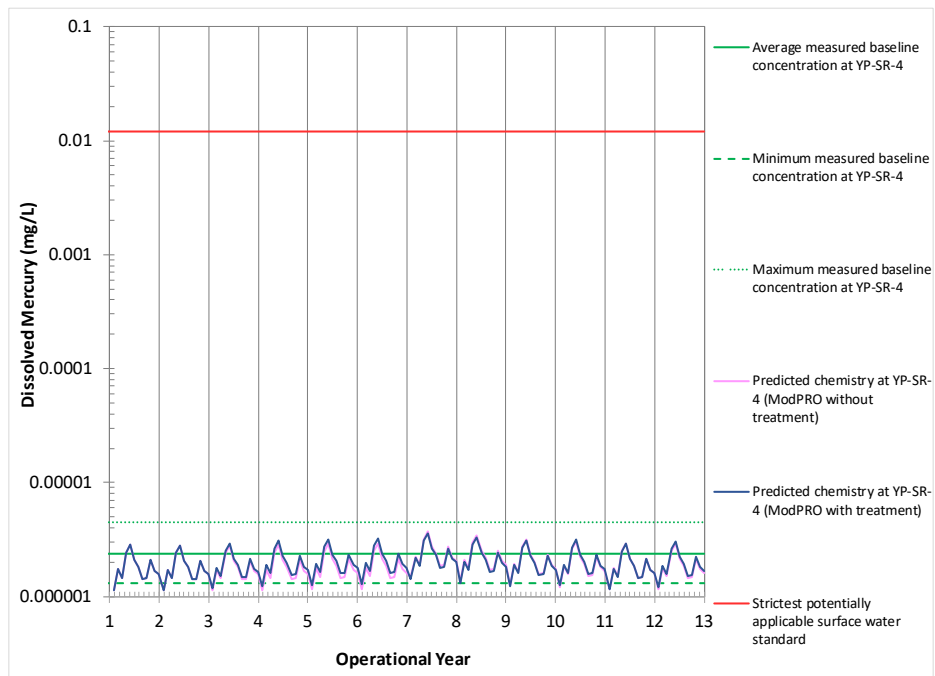

Figure A-6: Predicted Mercury Concentrations during Operations at Node YP-SR-4 – Treatment Evaluation Scenario

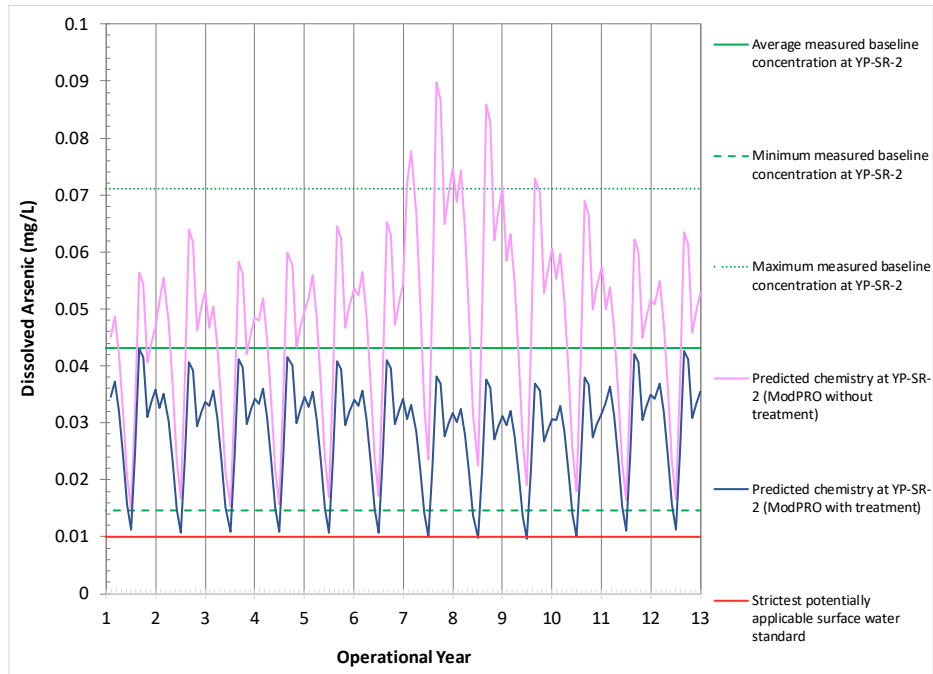

Figure A-7: Predicted Arsenic Concentrations during Operations at Node YP-SR-2 – Treatment Evaluation Scenario

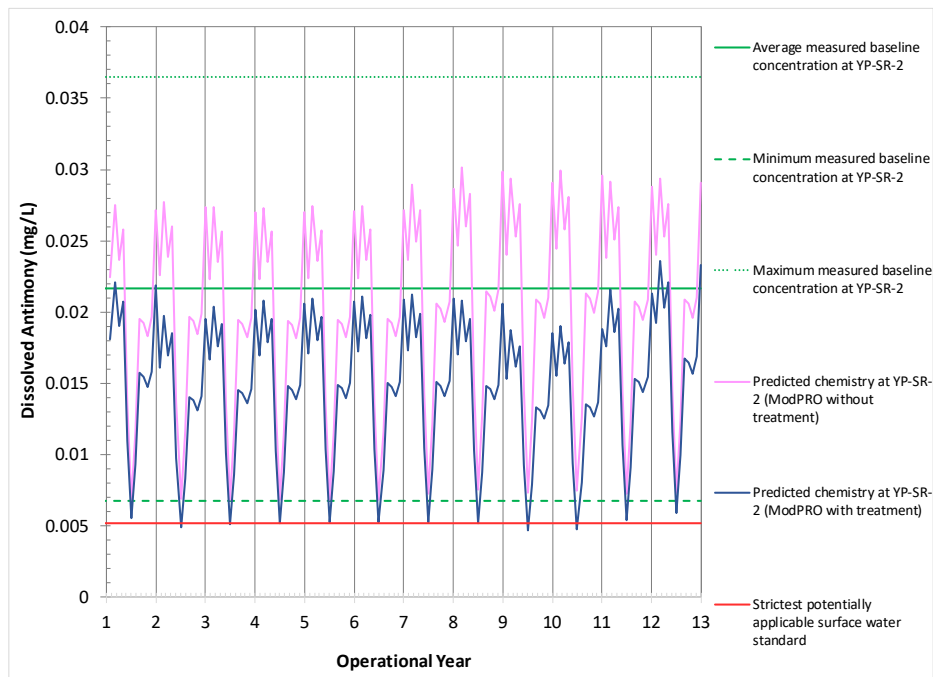

Figure A-8: Predicted Antimony Concentrations during Operations at Node YP-SR-2 – Treatment Evaluation Scenario

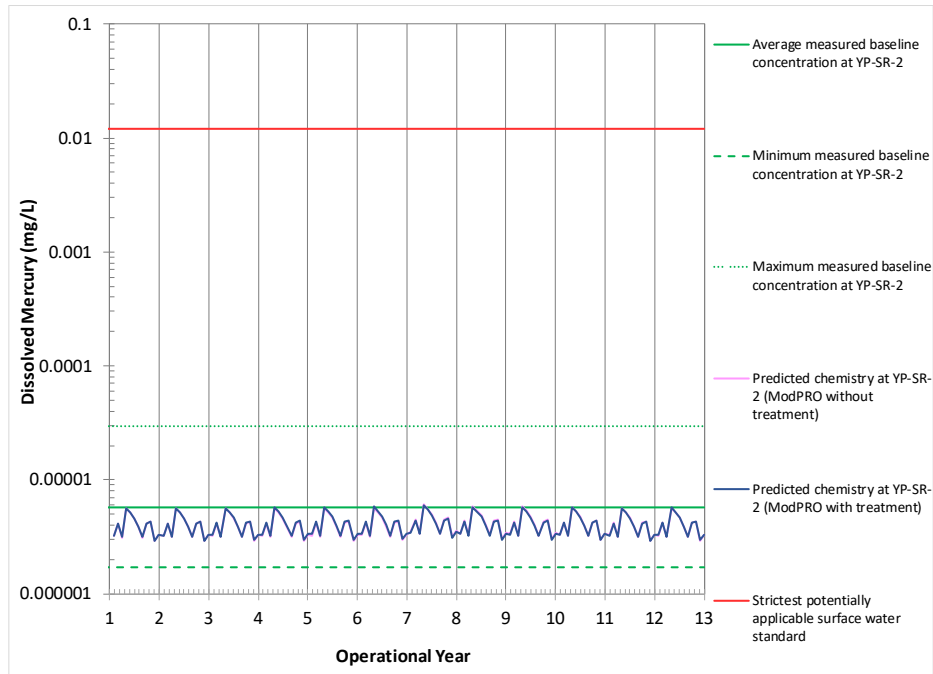

Figure A-9: Predicted Mercury Concentrations during Operations at Node YP-SR-2 – Treatment Evaluation Scenario

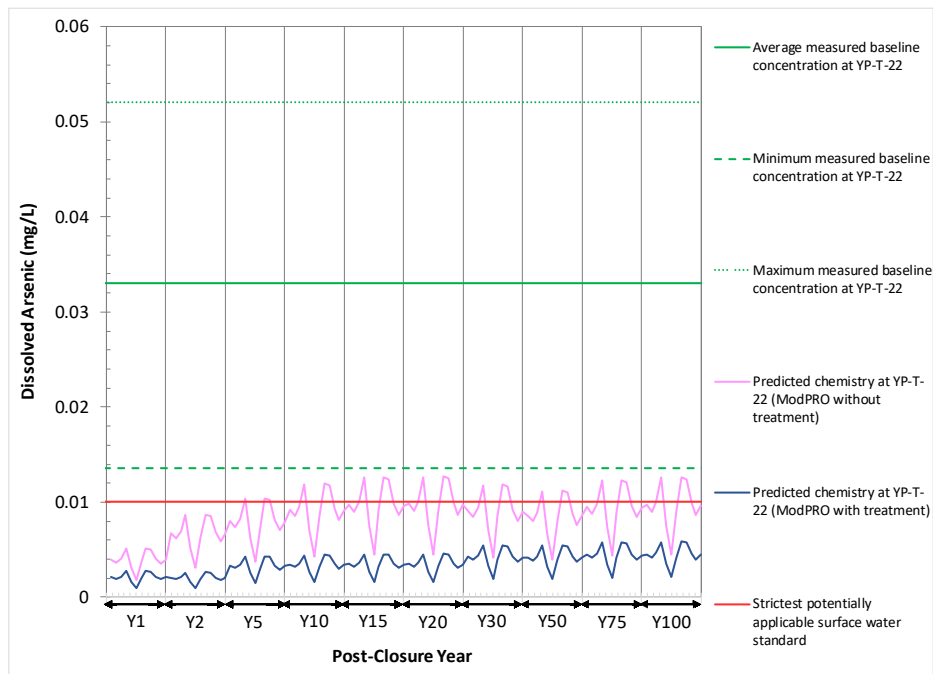

Figure A-10: Predicted Arsenic Concentrations during Post-closure at Node YP-T-22 – Treatment Evaluation Scenario

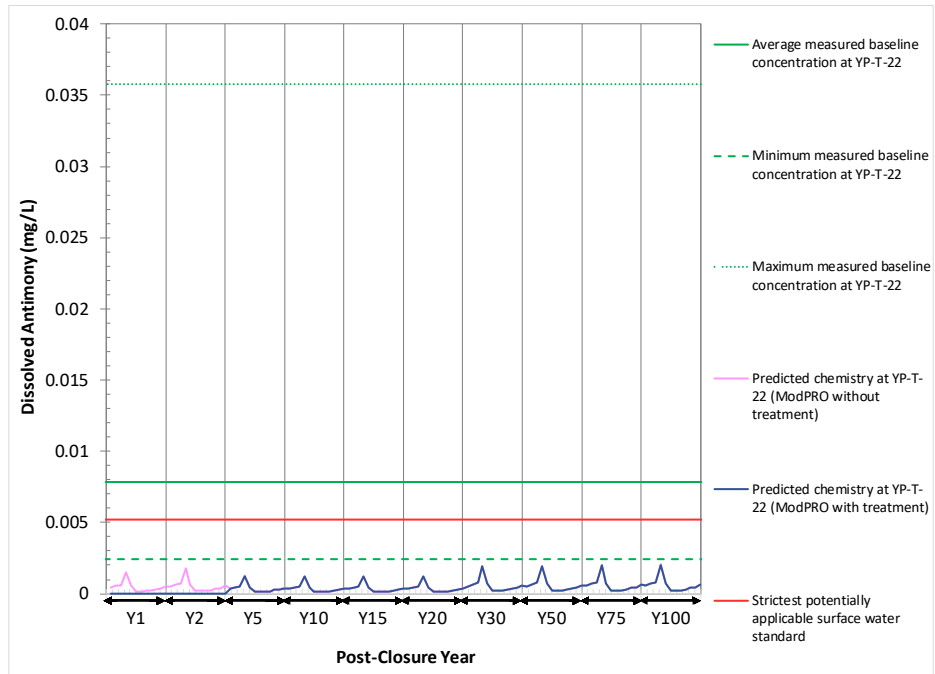

Figure A-11: Predicted Antimony Concentrations during Post-closure Node YP-T-22 – Treatment Evaluation Scenario

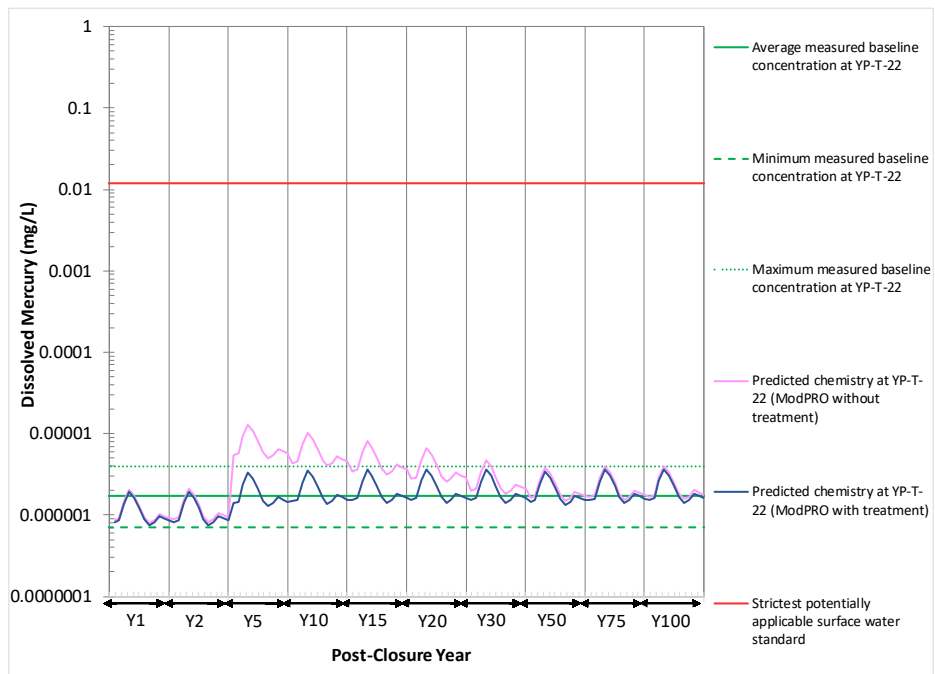

Figure A-12: Predicted Mercury Concentrations during Post-closure at Node YP-T-22 – Treatment Evaluation Scenario

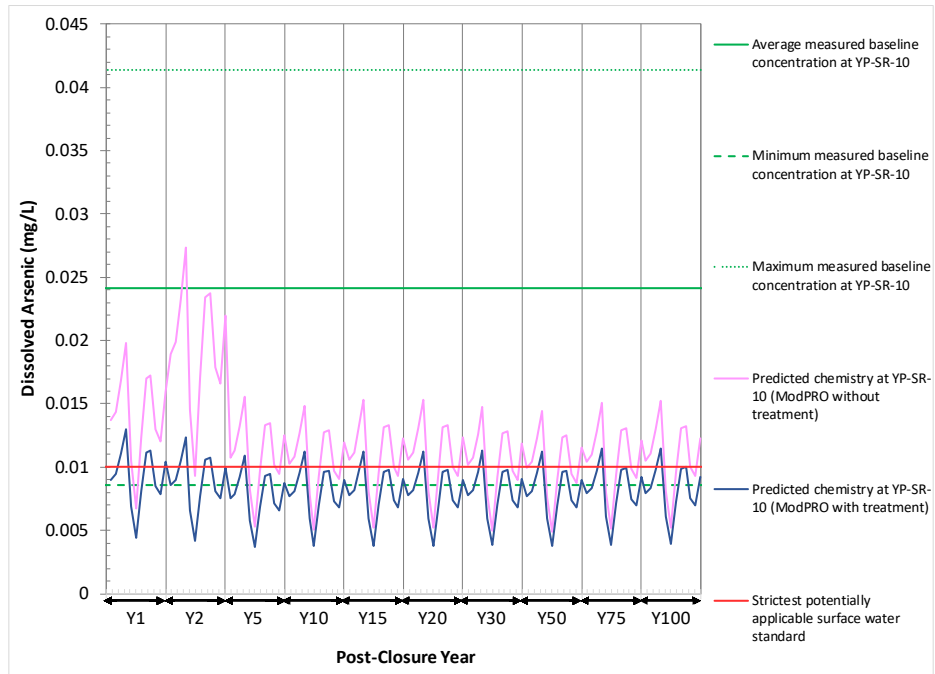

Figure A-13: Predicted Arsenic Concentrations during Post-closure at Node YP-SR-10 – Treatment Evaluation Scenario

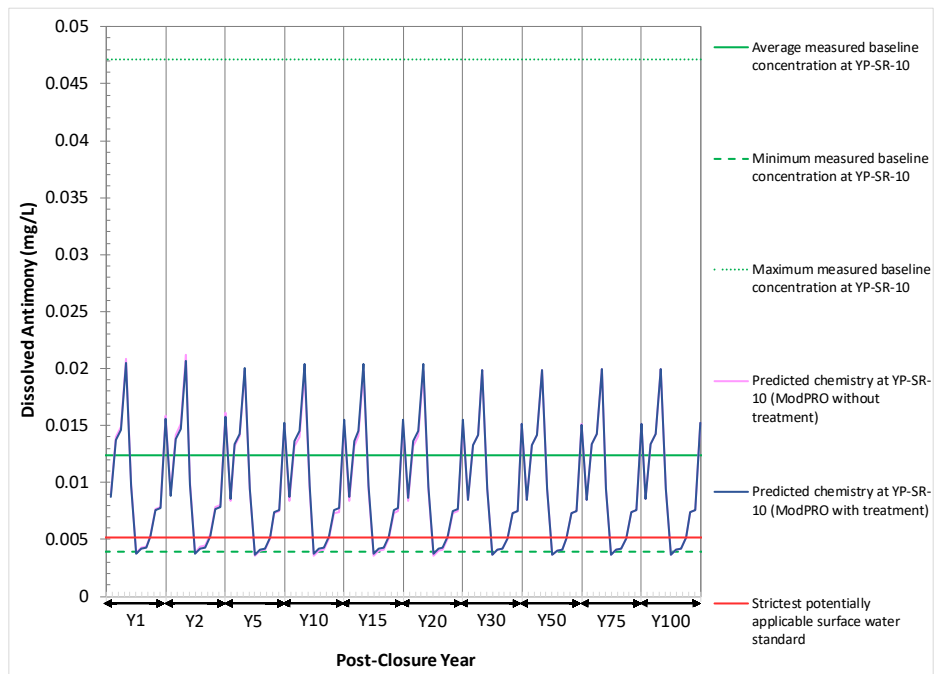

Figure A-14: Predicted Antimony Concentrations during Post-closure Node YP-SR-10 – Treatment Evaluation Scenario

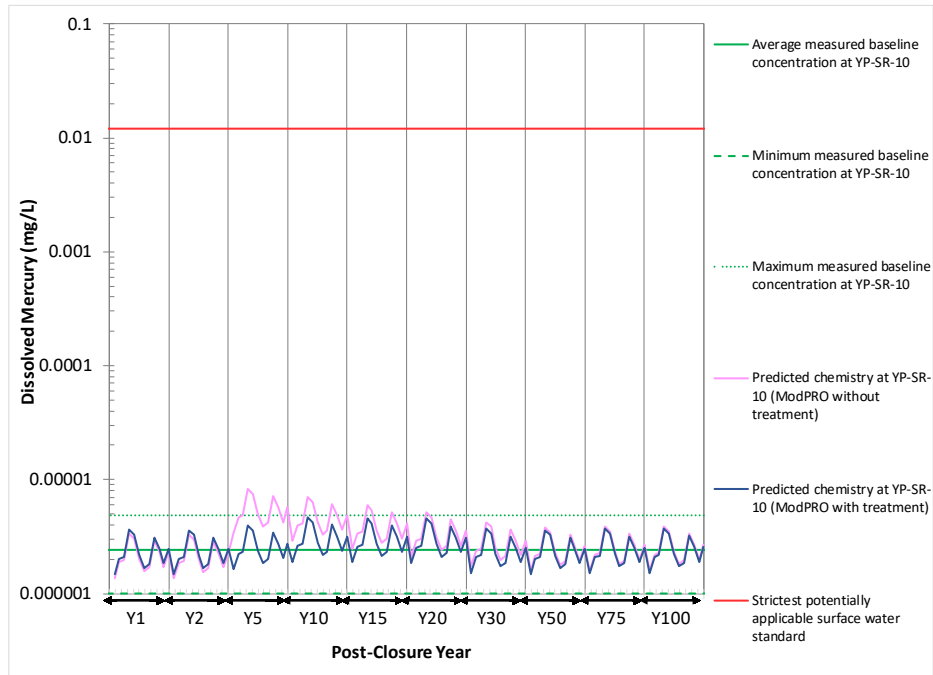

Figure A-15: Predicted Mercury Concentrations during Post-closure at Node YP-SR-10 – Treatment Evaluation Scenario

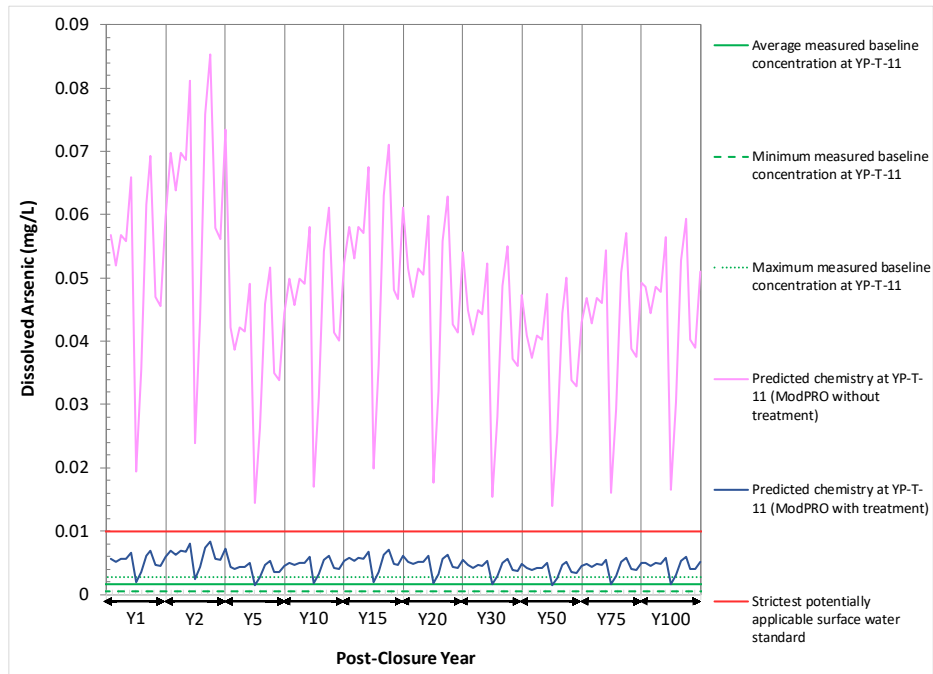

Figure A-16: Predicted Arsenic Concentrations during Post-closure at Node YP-T-11 – Treatment Evaluation Scenario

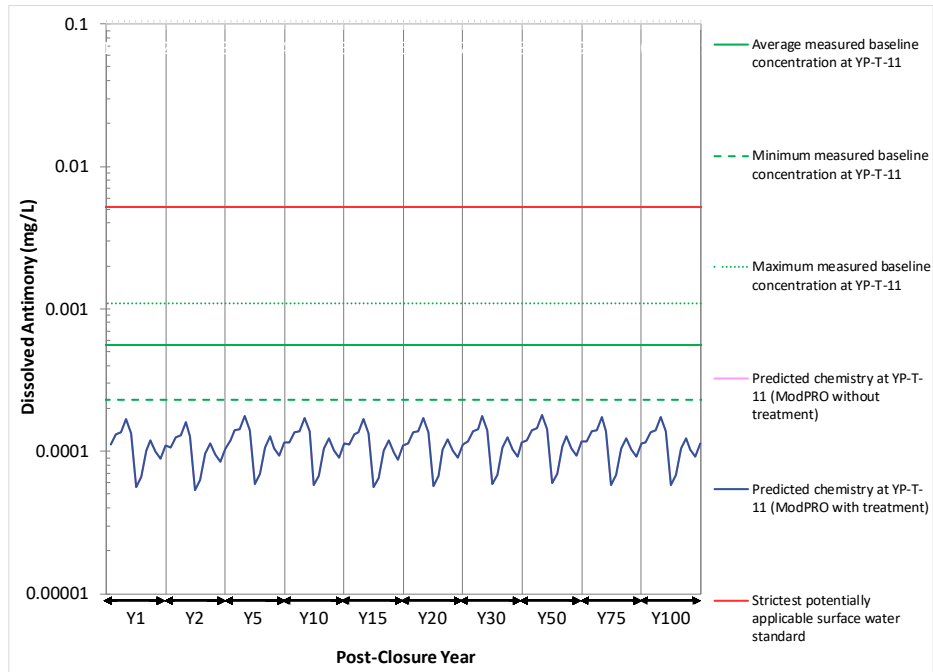

Figure A-17: Predicted Antimony Concentrations during Post-closure Node YP-T-11 – Treatment Evaluation Scenario

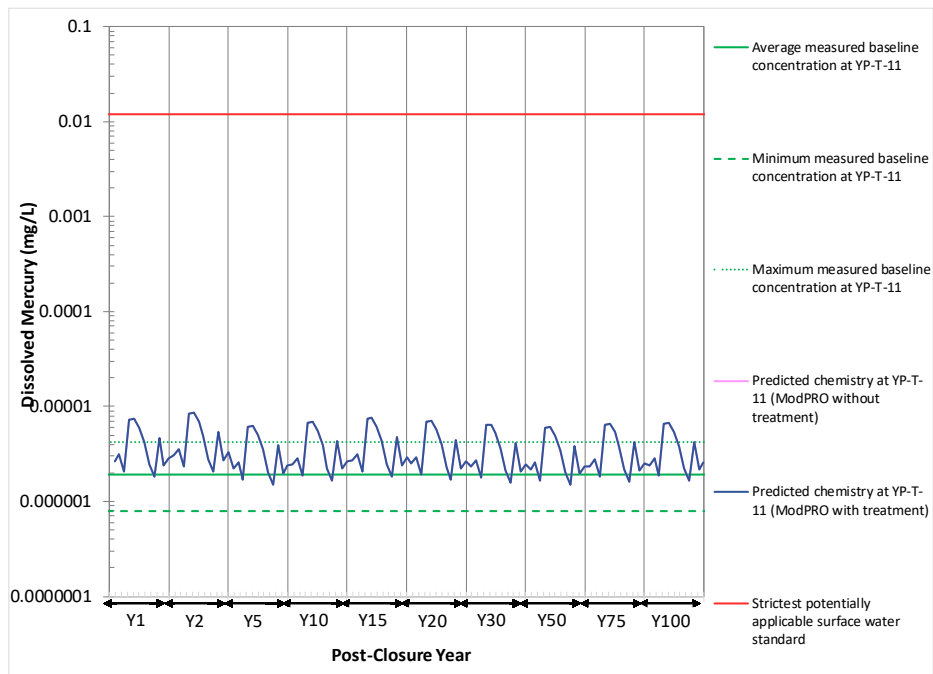

Figure A-18: Predicted Mercury Concentrations during Post-closure at Node YP-T-11 – Treatment Evaluation Scenario

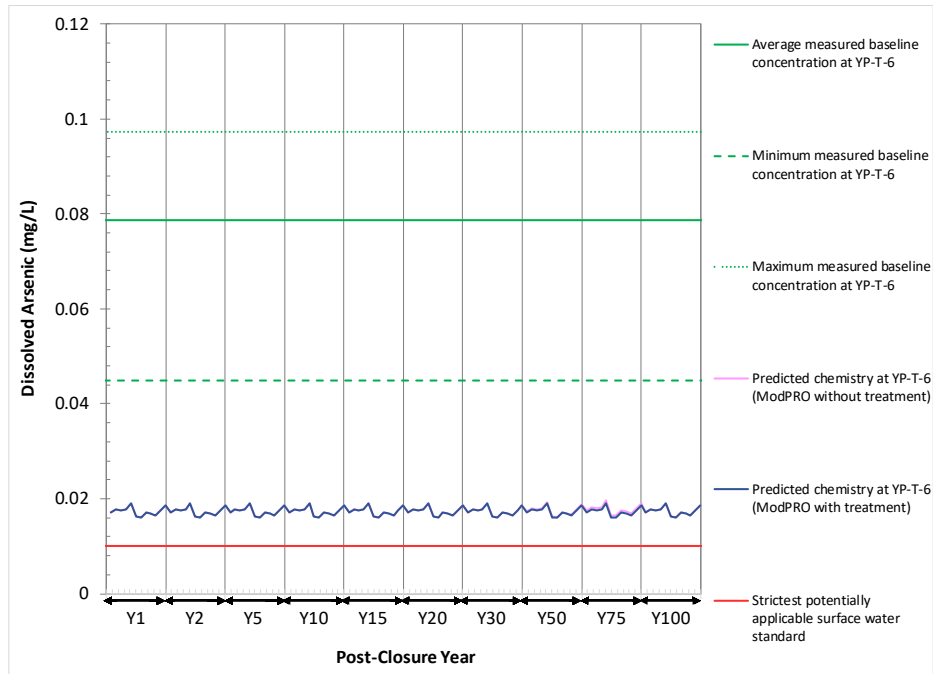

Figure A-19: Predicted Arsenic Concentrations during Post-closure at Node YP-T-6 – Treatment Evaluation Scenario

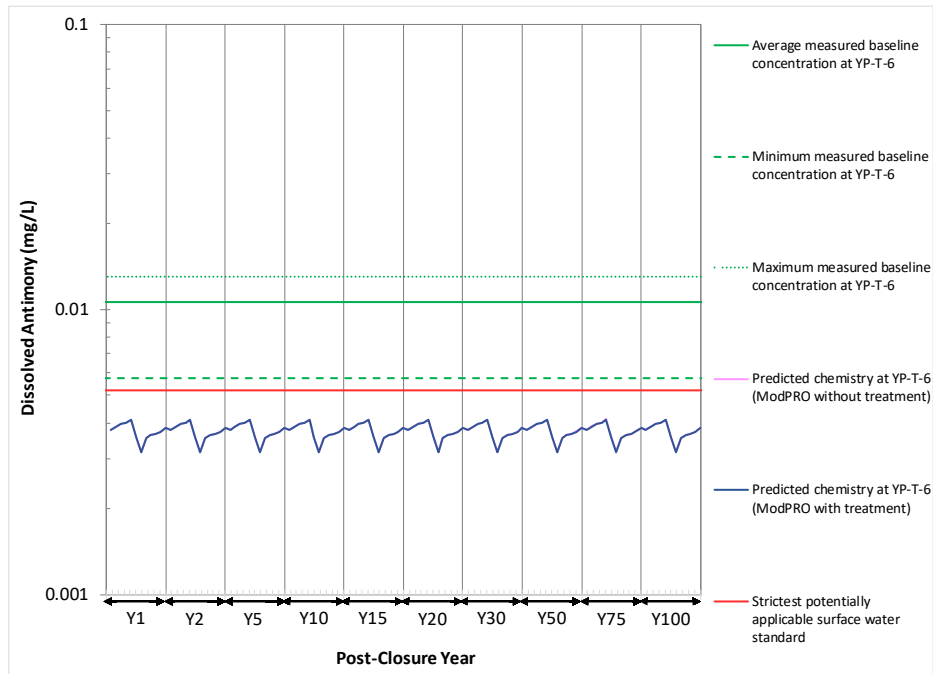

Figure A-20: Predicted Antimony Concentrations during Post-closure Node YP-T-6 – Treatment Evaluation Scenario

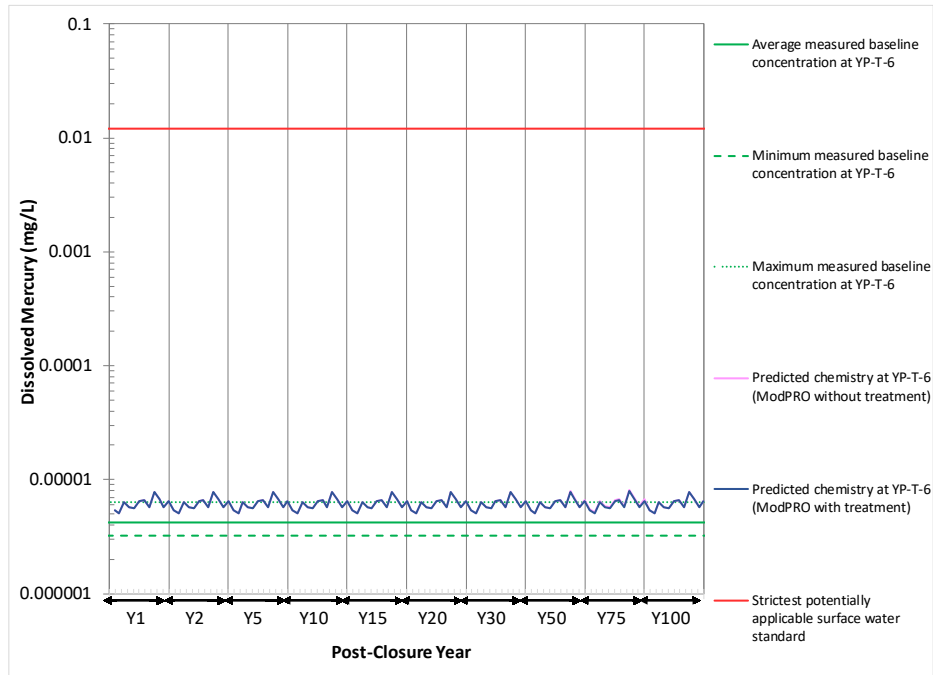

Figure A-21: Predicted Mercury Concentrations during Post-closure at Node YP-T-6 – Treatment Evaluation Scenario

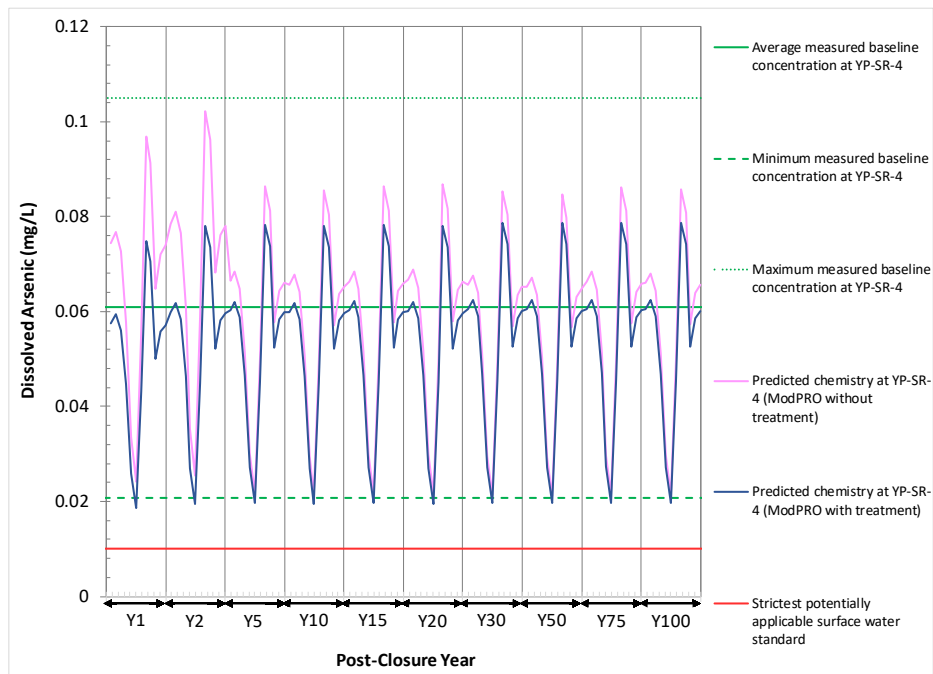

Figure A-22: Predicted Arsenic Concentrations during Post Closure at Node YP-SR-4 – Treatment Evaluation Scenario

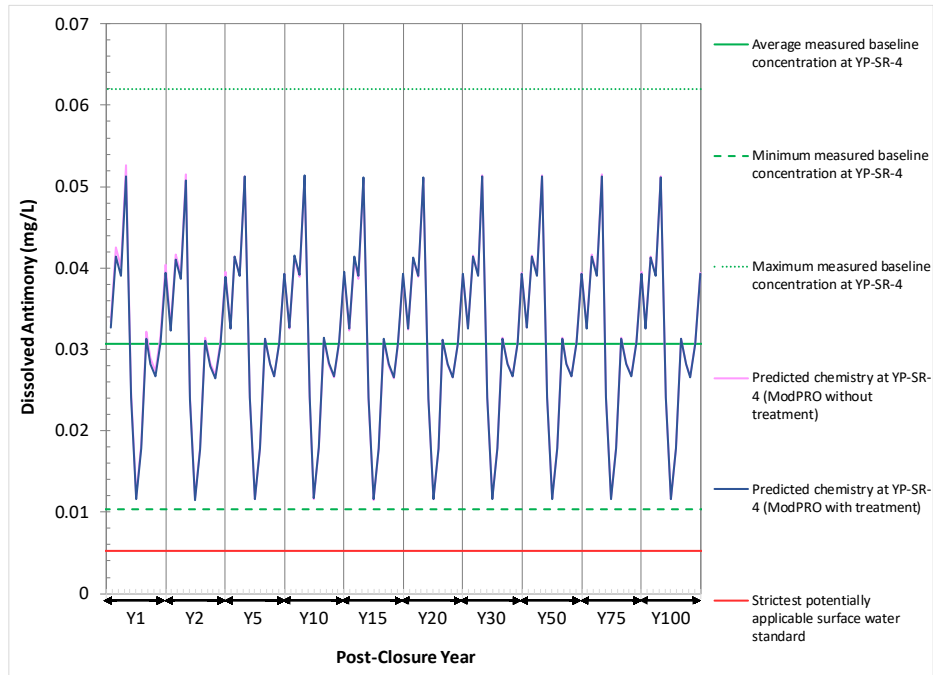

Figure A-23: Predicted Antimony Concentrations during Post Closure at Node YP-SR-4 – Treatment Evaluation Scenario

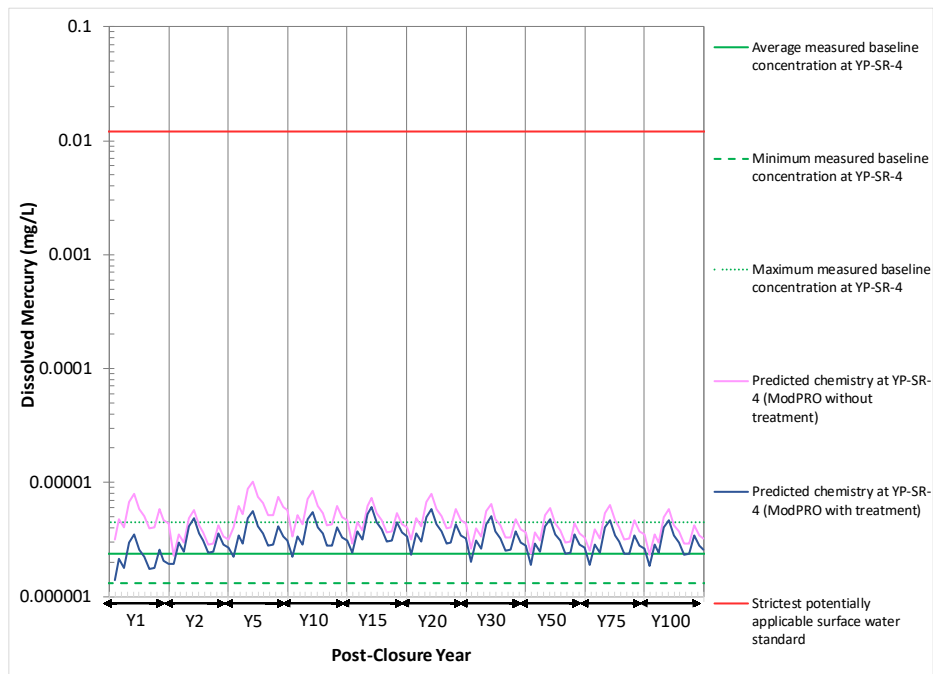

Figure A-24: Predicted Mercury Concentrations during Post Closure at Node YP-SR-4 – Treatment Evaluation Scenario

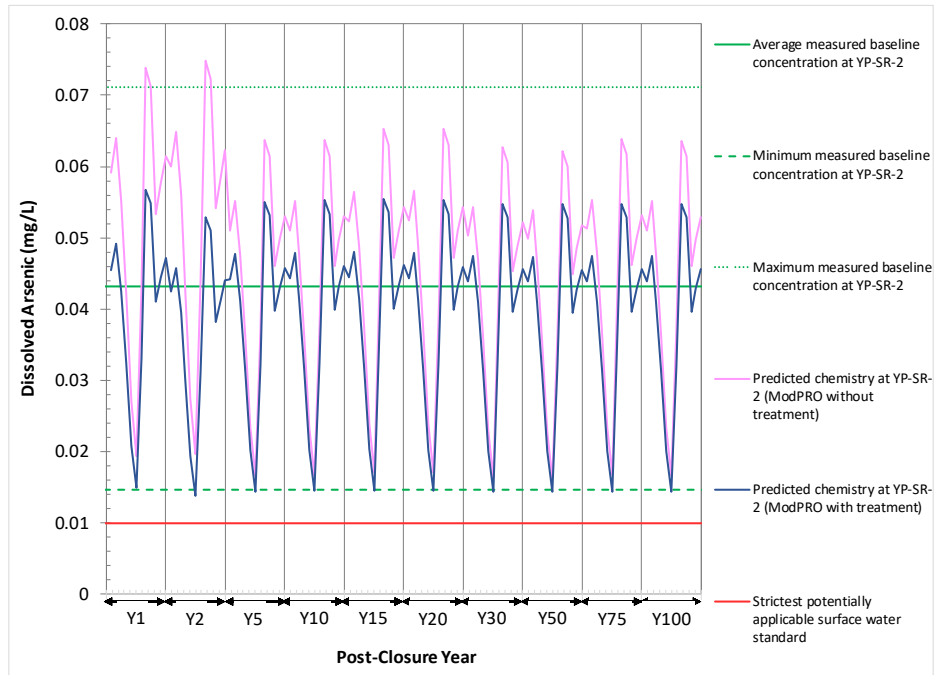

Figure A-25: Predicted Arsenic Concentrations during Post Closure at Node YP-SR-2 – Treatment Evaluation Scenario

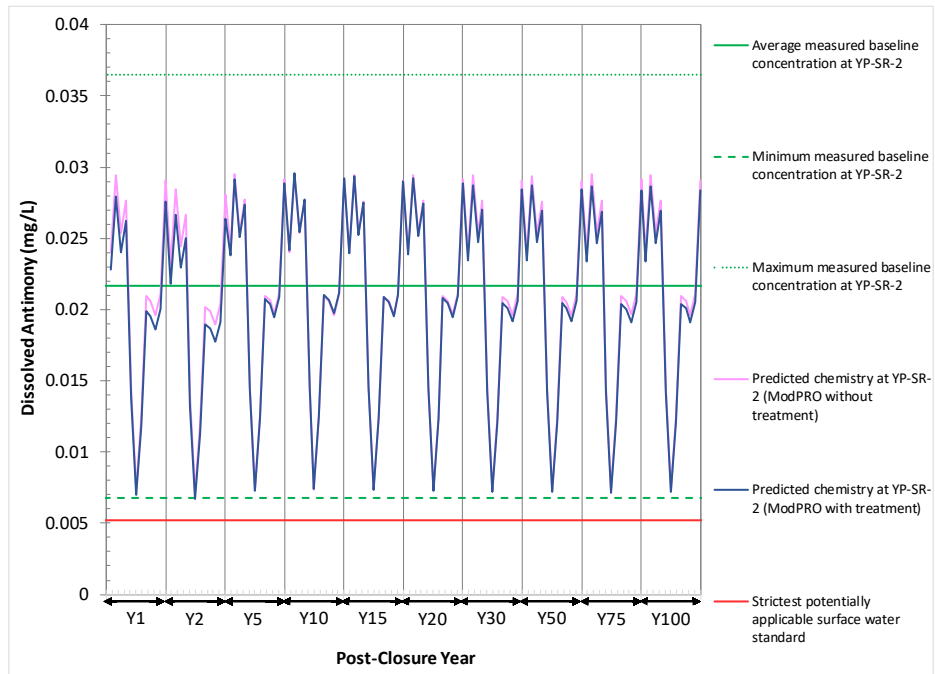

Figure A-26: Predicted Antimony Concentrations during Post Closure at Node YP-SR-2 – Treatment Evaluation Scenario

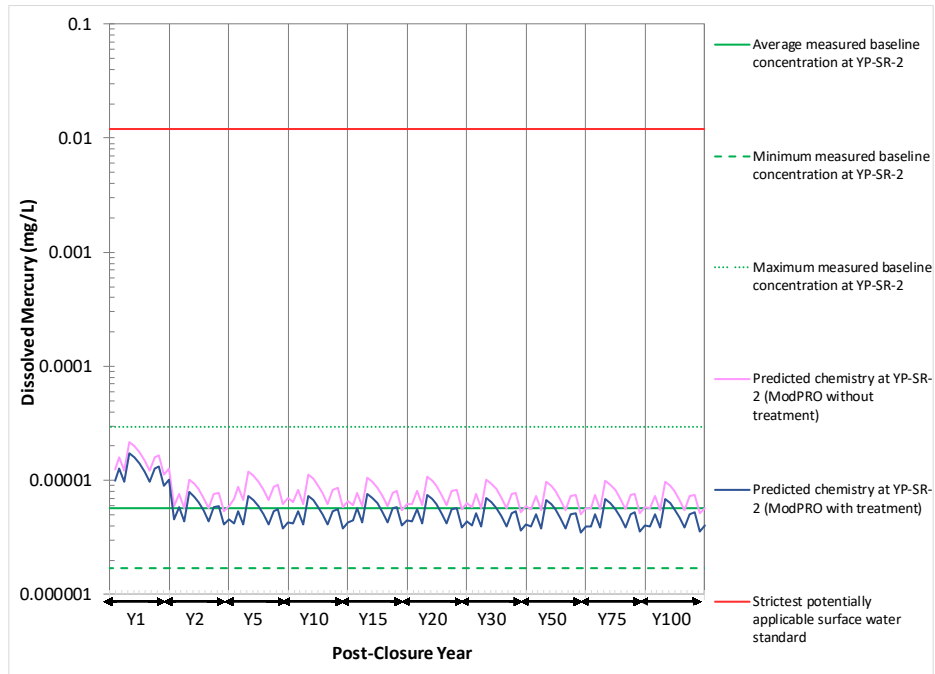

Figure A-27: Predicted Mercury Concentrations during Post Closure at Node YP-SR-2 – Treatment Evaluation Scenario

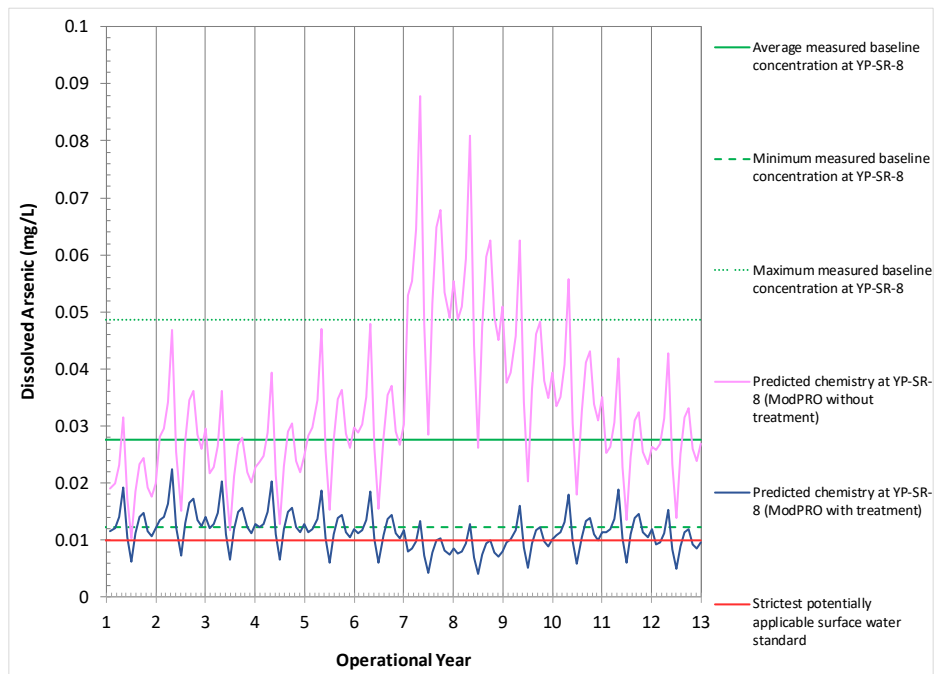

Figure A-28: Predicted Arsenic Concentrations during Operations at Node YP-SR-8 – Treatment Evaluation Scenario

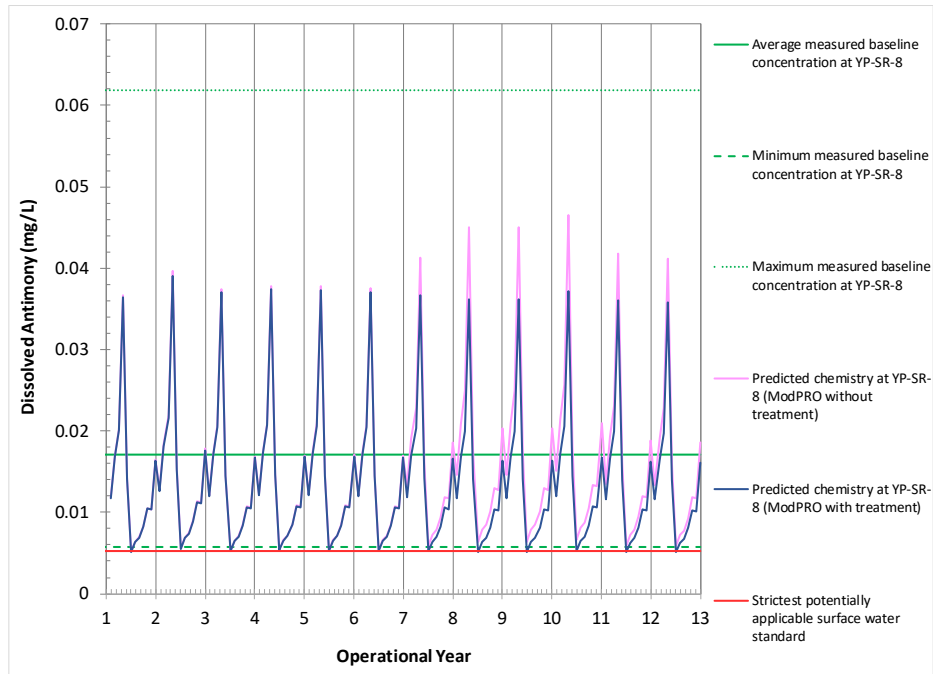

Figure A-29: Predicted Antimony Concentrations during Operations at Node YP-SR-8 – Treatment Evaluation Scenario

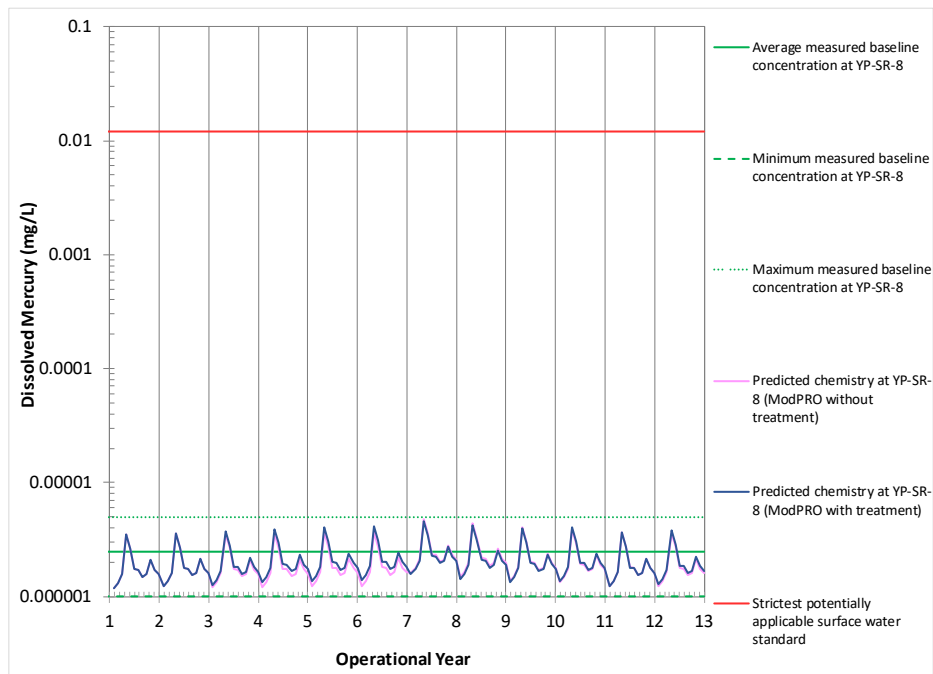

Figure A-30: Predicted Mercury Concentrations during Operations at Node YP-SR-8 – Treatment Evaluation Scenario

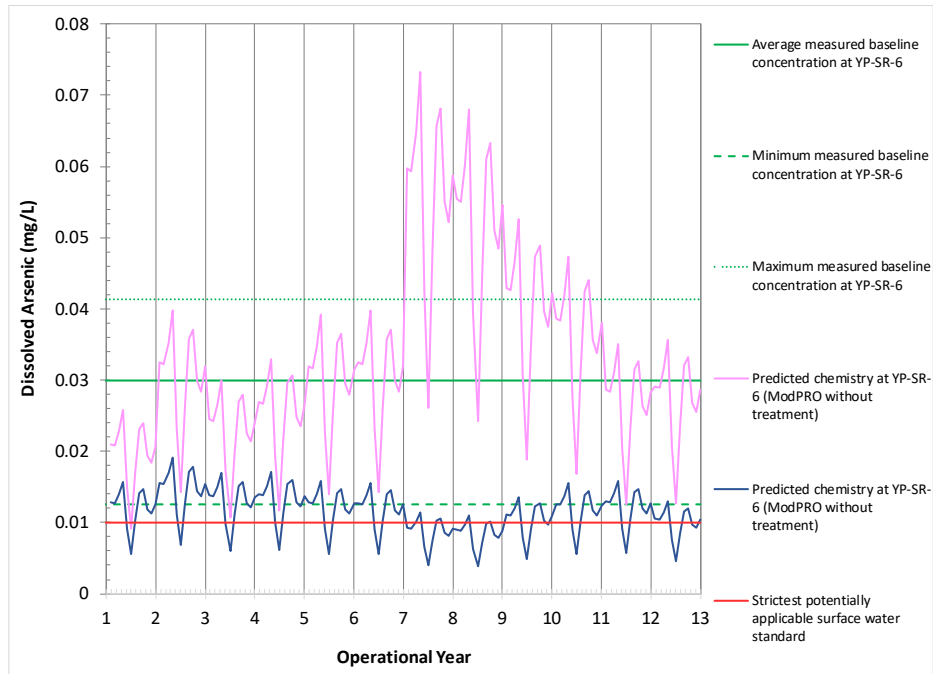

Figure A-31: Predicted Arsenic Concentrations during Operations at Node YP-SR-6 – Treatment Evaluation Scenario

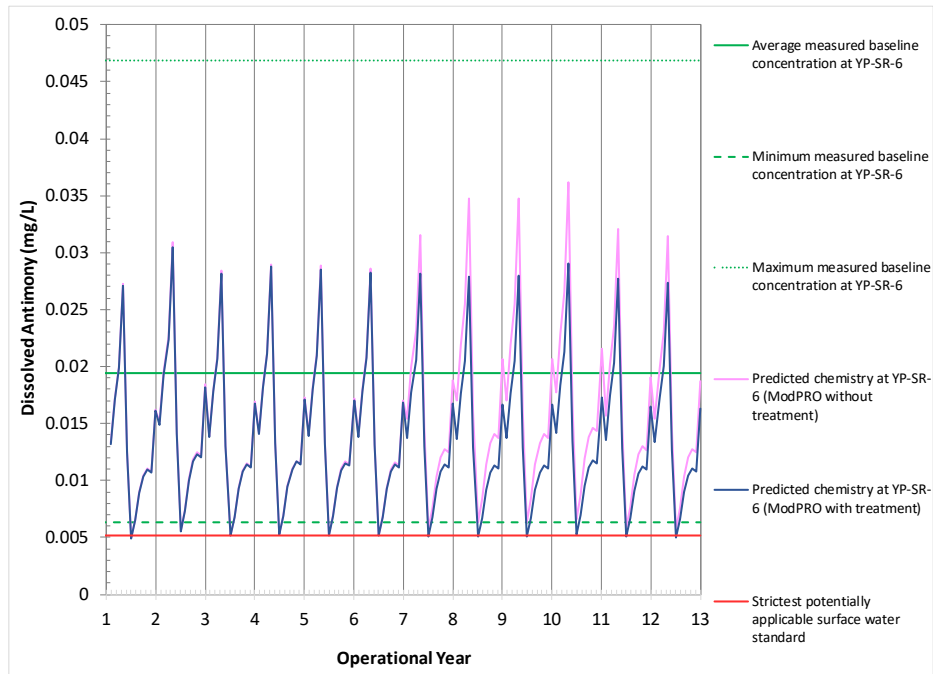

Figure A-32: Predicted Antimony Concentrations during Operations at Node YP-SR-6 – Treatment Evaluation Scenario

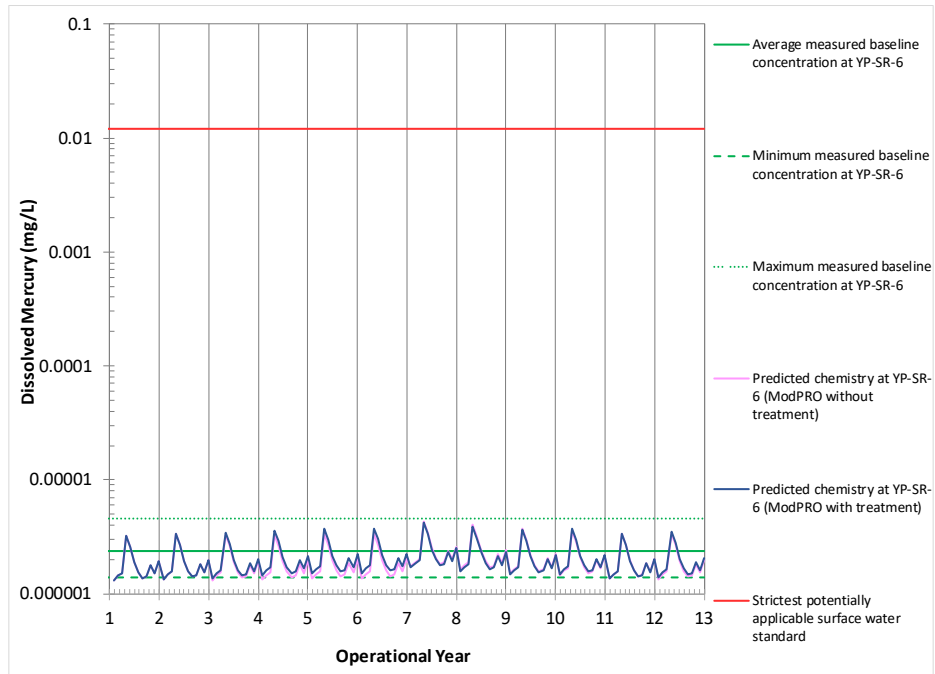

Figure A-33: Predicted Mercury Concentrations during Operations at Node YP-SR-6 – Treatment Evaluation Scenario

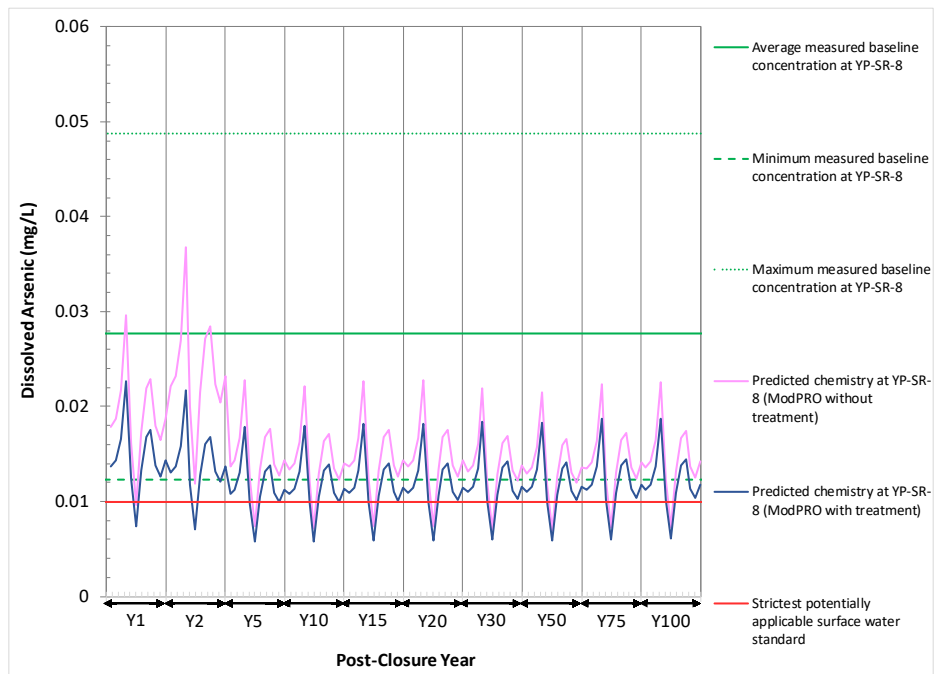

Figure A-34: Predicted Arsenic Concentrations during Post-closure at Node YP-SR-8 – Treatment Evaluation Scenario

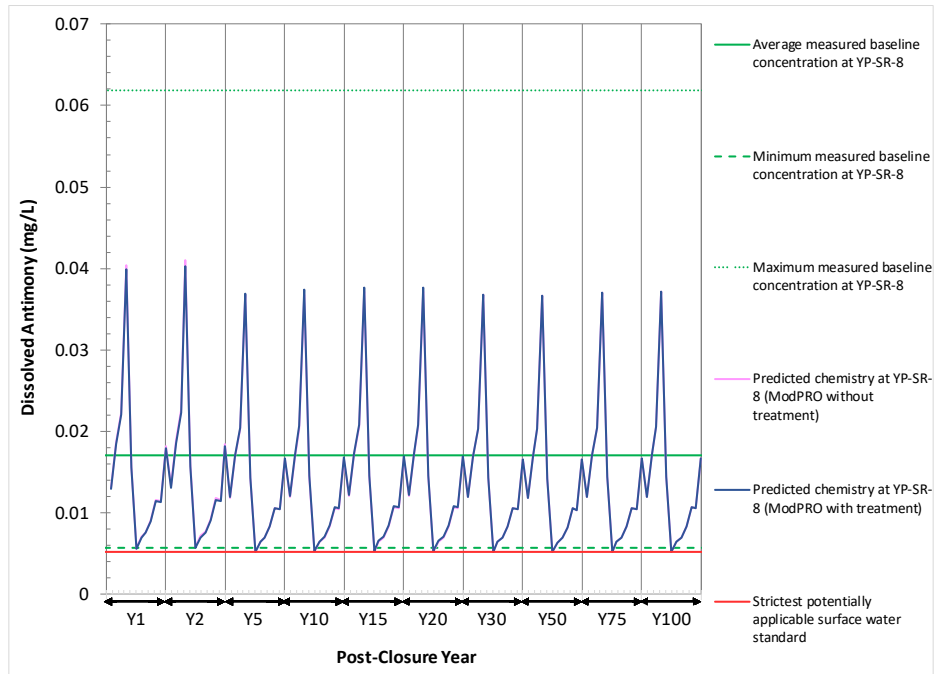

Figure A-35: Predicted Antimony Concentrations during Post-closure Node YP-SR-8 – Treatment Evaluation Scenario

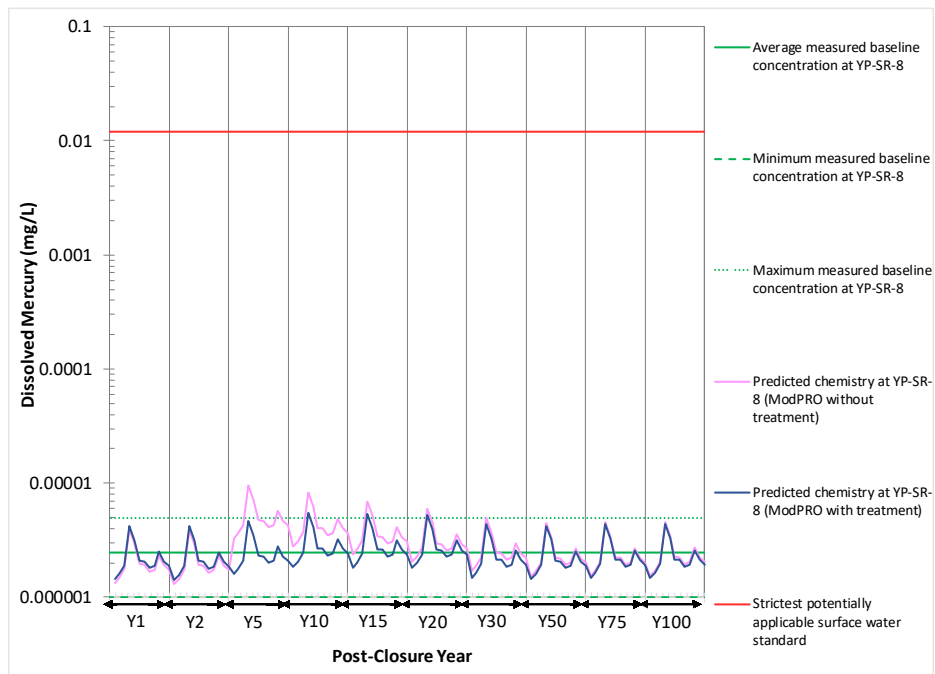

Figure A-36: Predicted Mercury Concentrations during Post-closure at Node YP-SR-8 – Treatment Evaluation Scenario

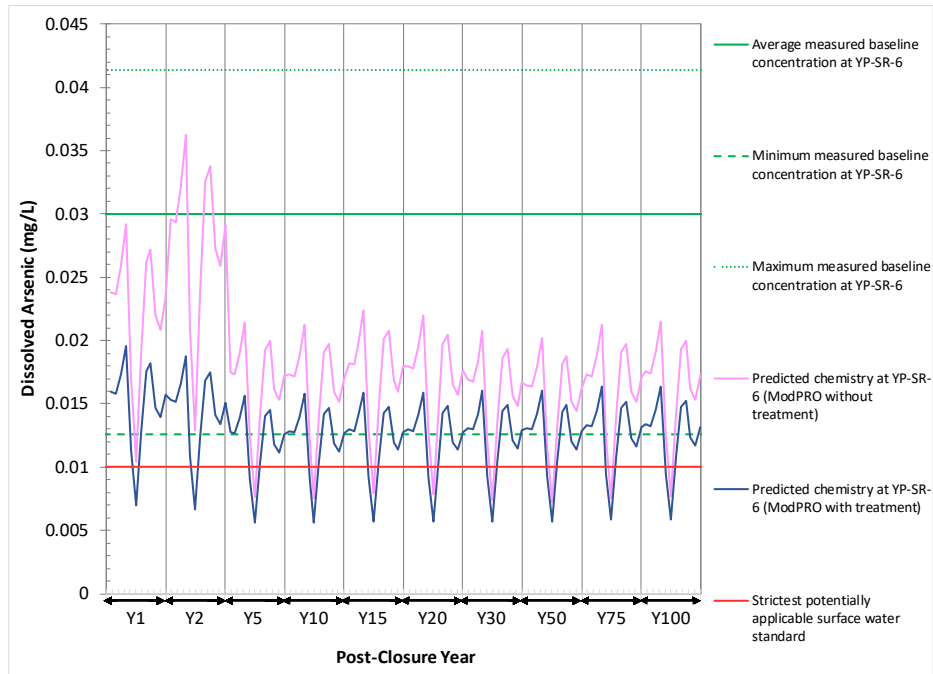

Figure A-37: Predicted Arsenic Concentrations during Post-closure at Node YP-SR-6 – Treatment Evaluation Scenario

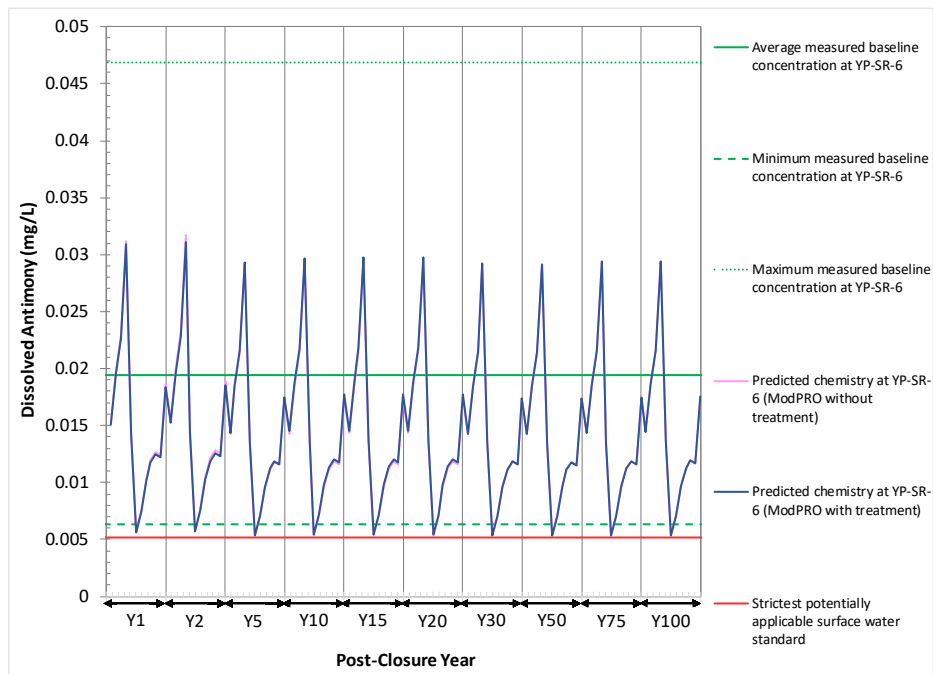

Figure A-38: Predicted Antimony Concentrations during Post-closure Node YP-SR-6 – Treatment Evaluation Scenario

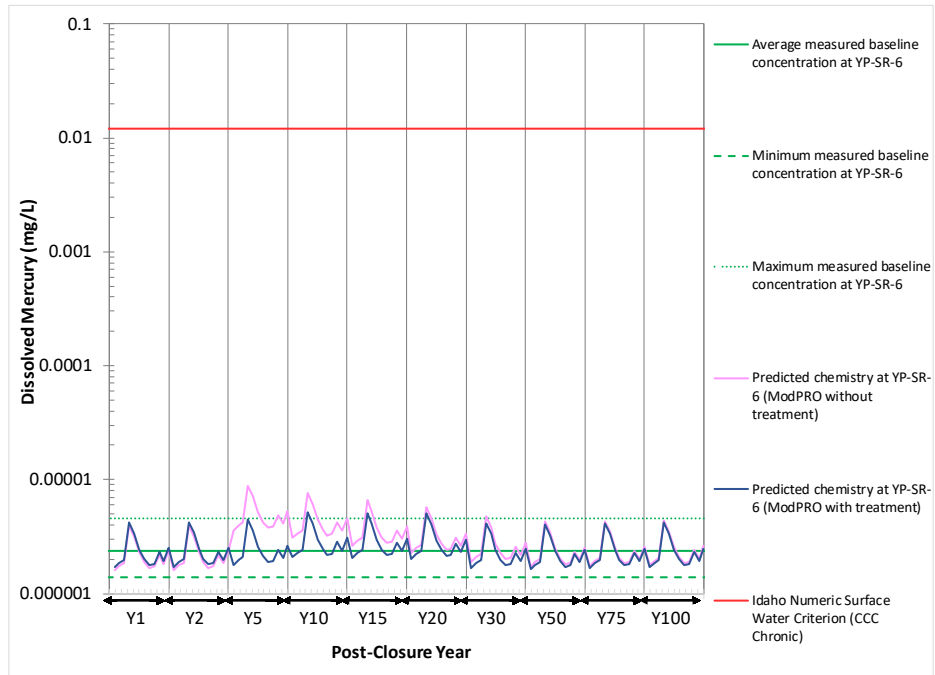

Figure A-39: Predicted Mercury Concentrations during Post-closure at Node YP-SR-6 – Treatment Evaluation Scenario

# Attachment B

---

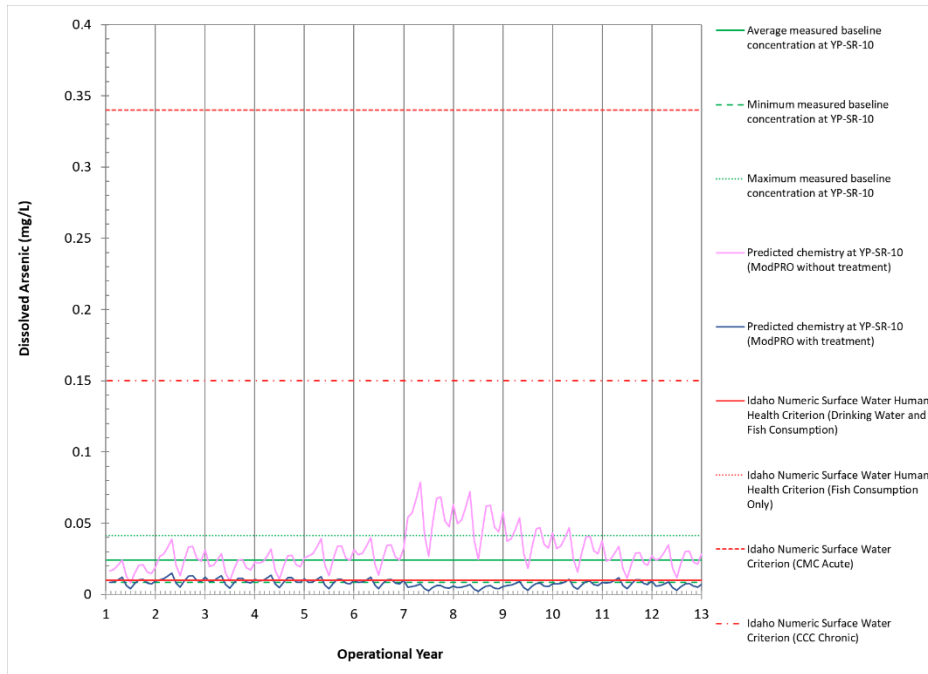

Figure B-1: Predicted Arsenic Concentrations during Operations at Node YP-SR-10 – Treatment Evaluation Scenario

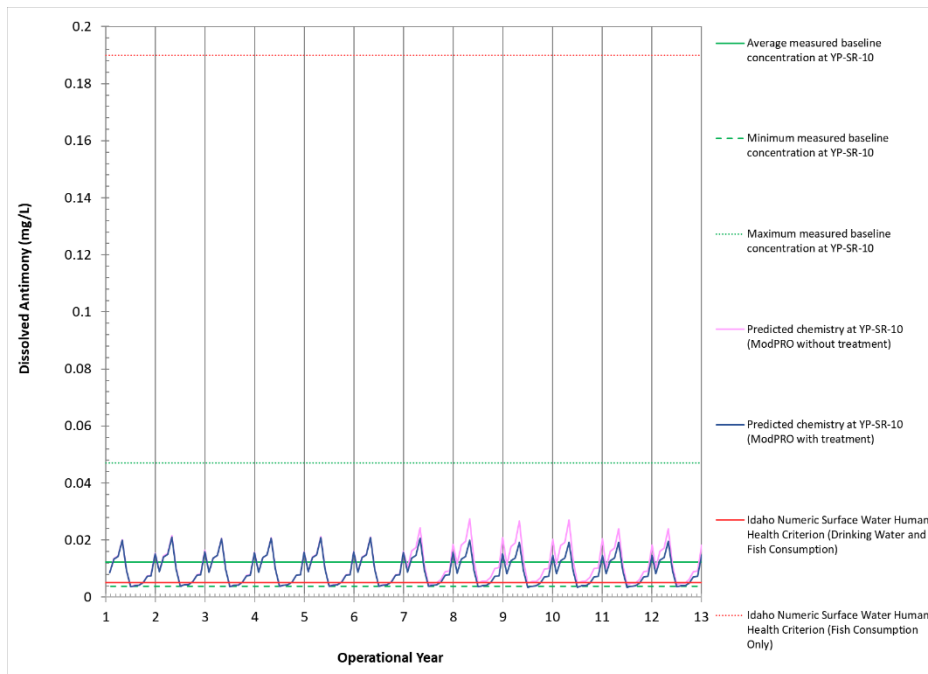

Figure B-2: Predicted Antimony Concentrations during Operations at Node YP-SR-10 – Treatment Evaluation Scenario

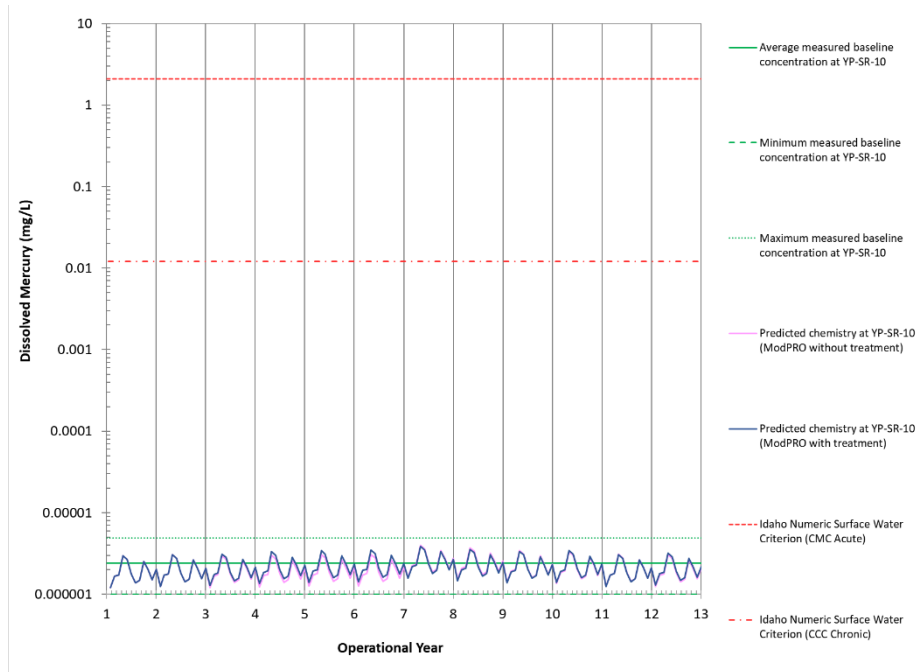

Figure B-3: Predicted Mercury Concentrations during Operations at Node YP-SR-10 – Treatment Evaluation Scenario

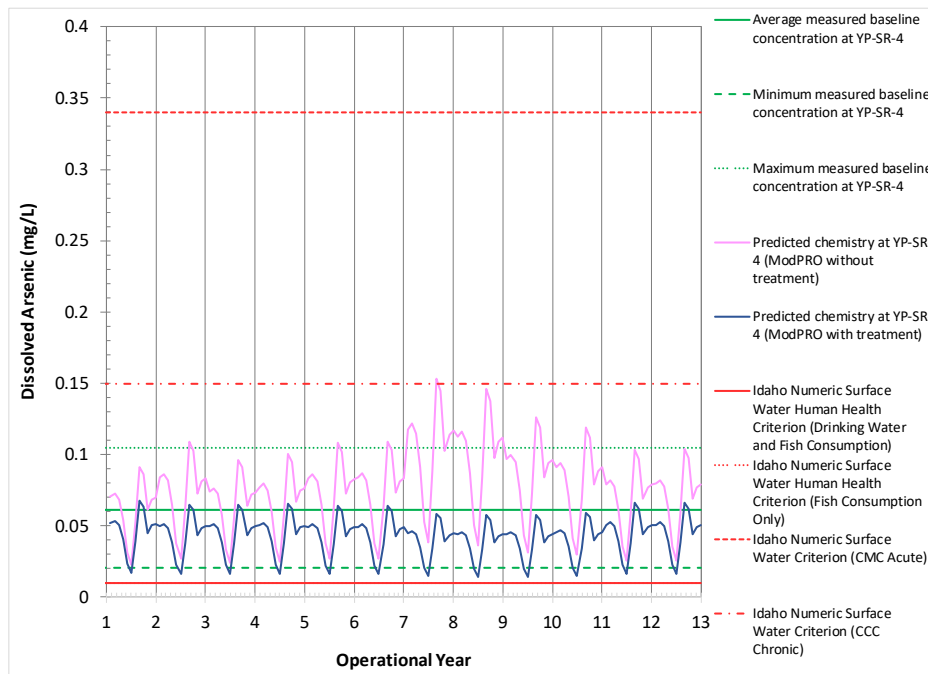

Figure B-4: Predicted Arsenic Concentrations during Operations at Node YP-SR-4 – Treatment Evaluation Scenario

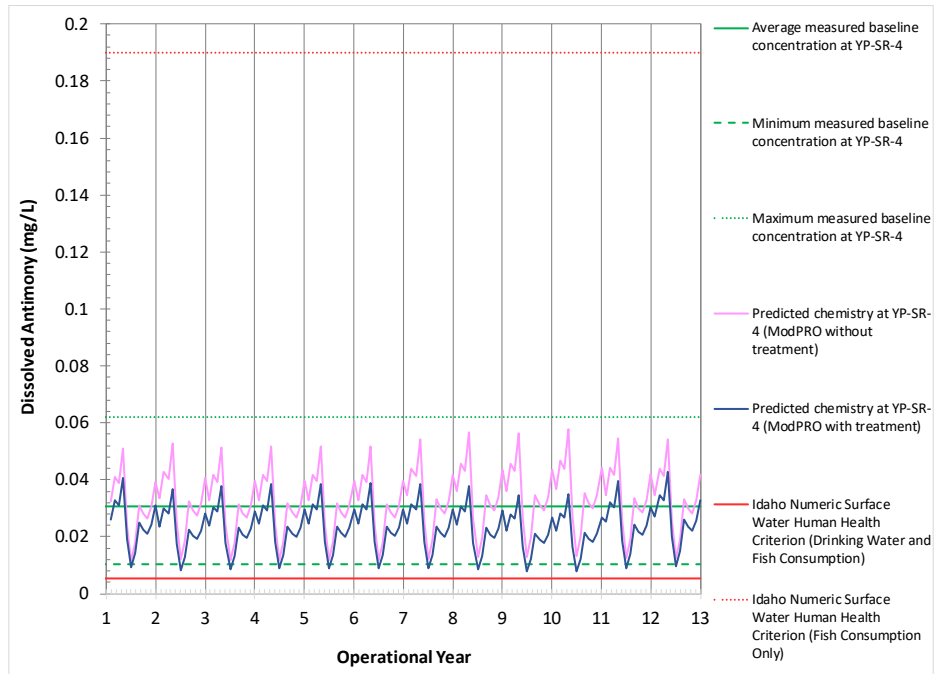

Figure B-5: Predicted Antimony Concentrations during Operations at Node YP-SR-4 – Treatment Evaluation Scenario

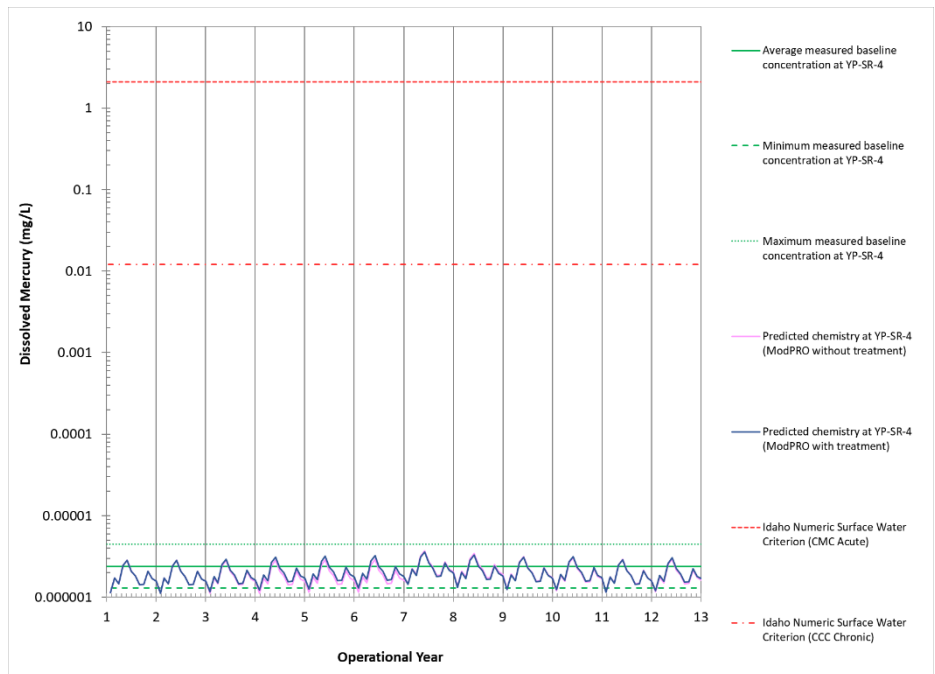

Figure B-6: Predicted Mercury Concentrations during Operations at Node YP-SR-4 – Treatment Evaluation Scenario

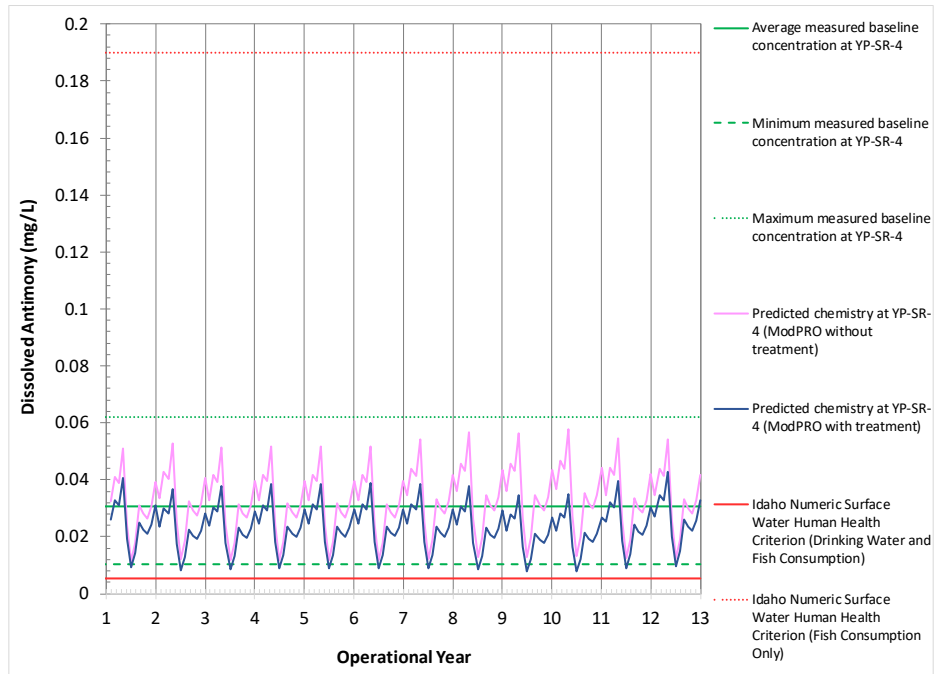

Figure B-7: Predicted Arsenic Concentrations during Operations at Node YP-SR-2 – Treatment Evaluation Scenario

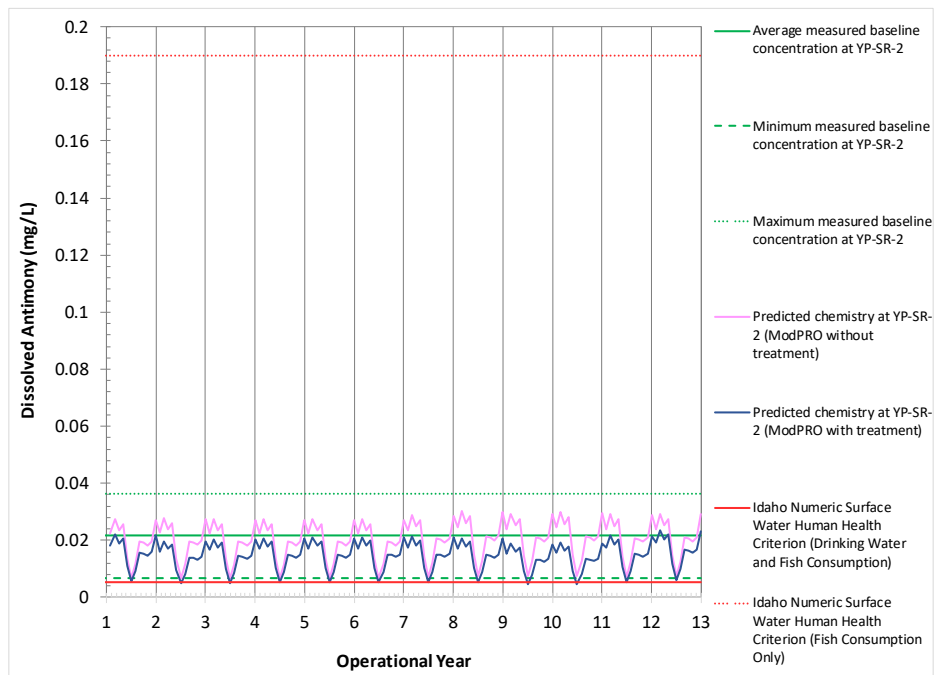

Figure B-8: Predicted Antimony Concentrations during Operations at Node YP-SR-2 – Treatment Evaluation Scenario

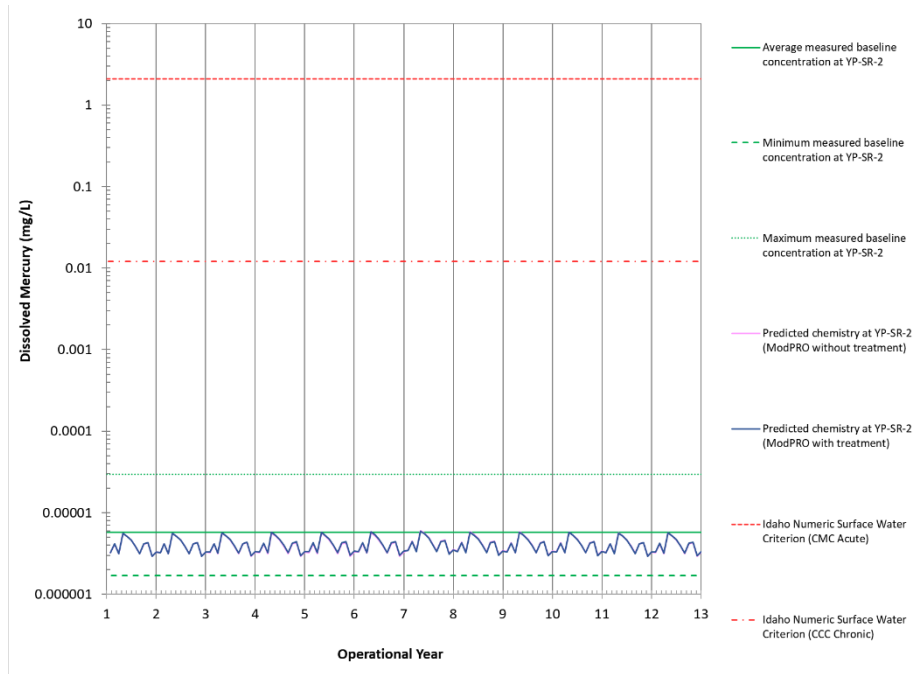

Figure B-9: Predicted Mercury Concentrations during Operations at Node YP-SR-2 – Treatment Evaluation Scenario

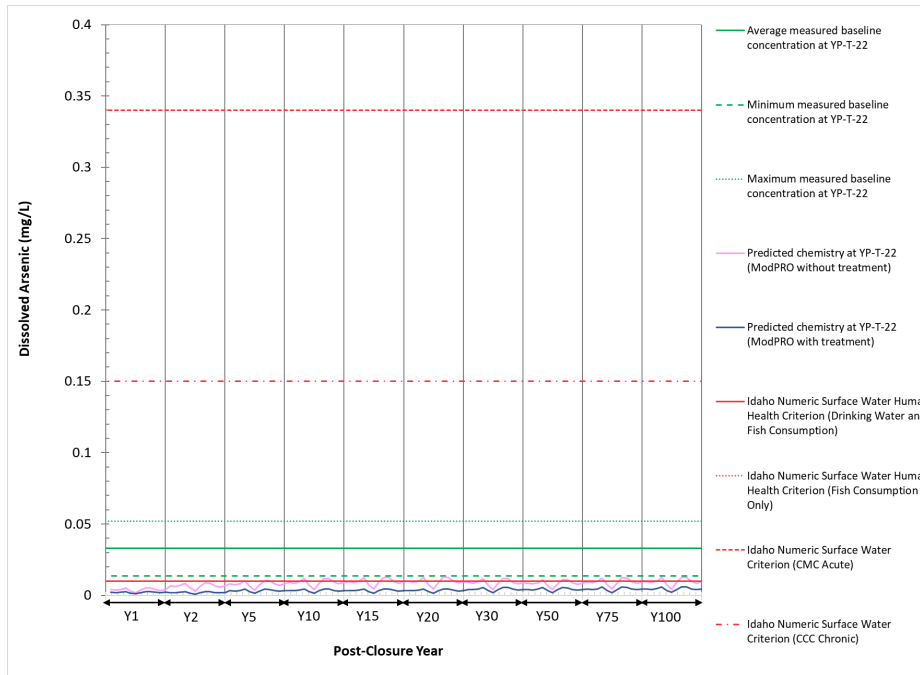

Figure B-10: Predicted Arsenic Concentrations during Post-closure at Node YP-T-22 – Treatment Evaluation Scenario

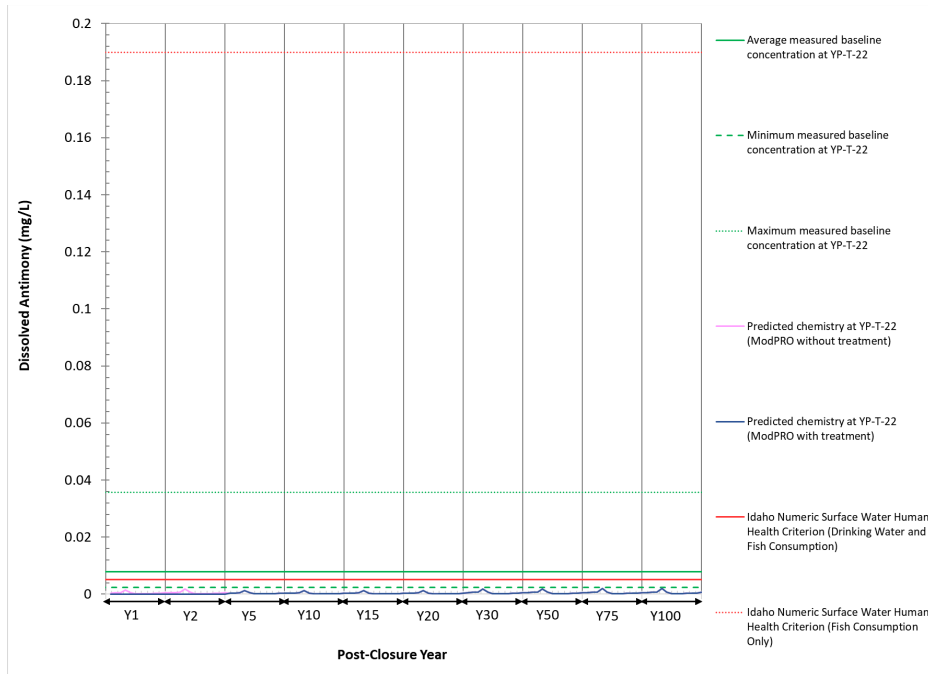

Figure B-11: Predicted Antimony Concentrations during Post-closure Node YP-T-22 – Treatment Evaluation Scenario

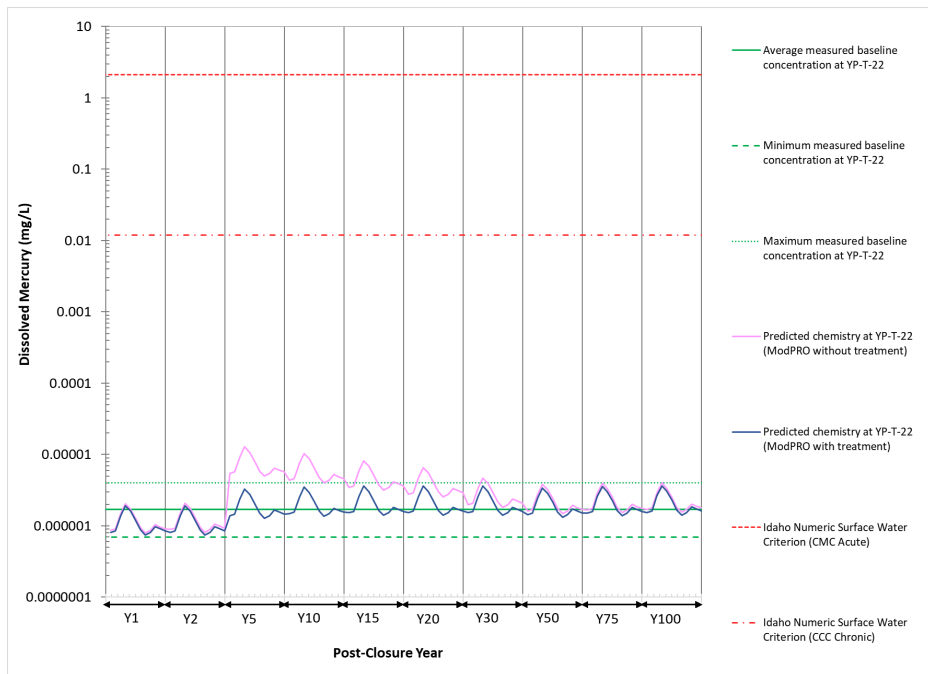

Figure B-12: Predicted Mercury Concentrations during Post-closure at Node YP-T-22 – Treatment Evaluation Scenario

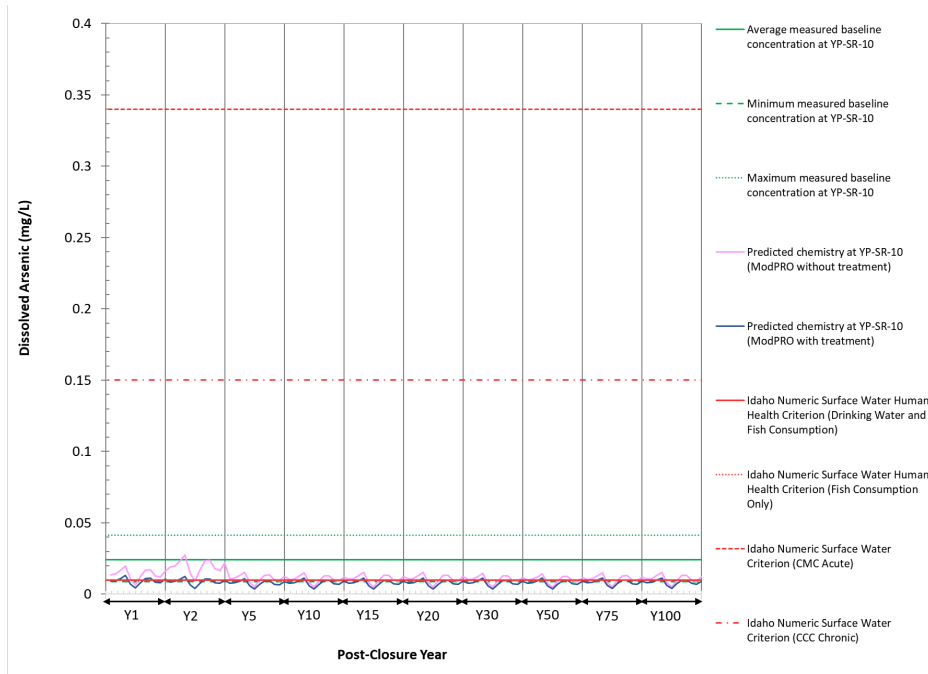

Figure B-13: Predicted Arsenic Concentrations during Post-closure at Node YP-SR-10 – Treatment Evaluation Scenario

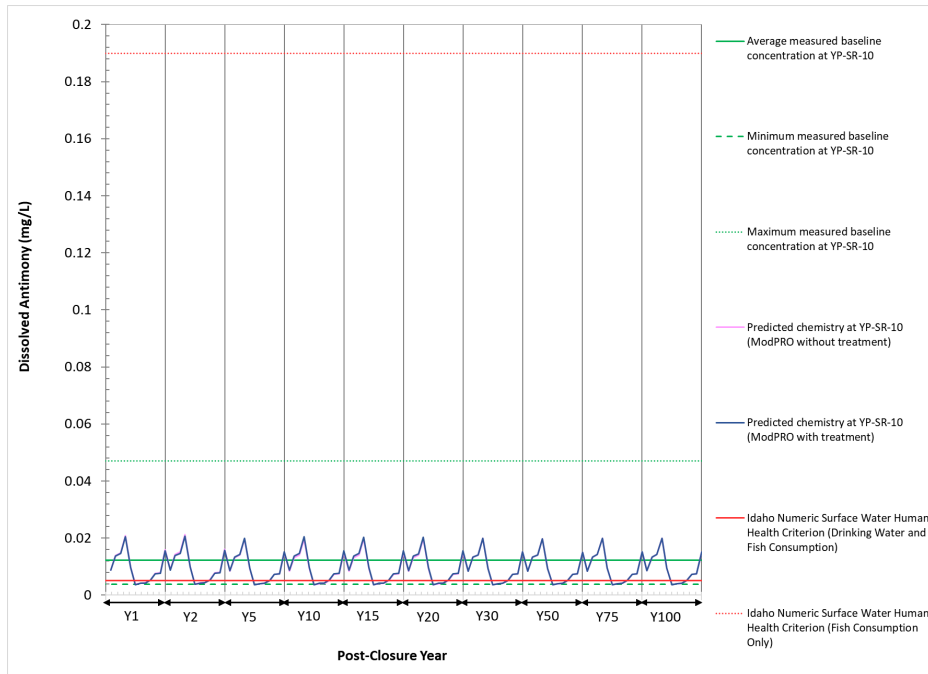

Figure B-14: Predicted Antimony Concentrations during Post-closure Node YP-SR-10 – Treatment Evaluation Scenario

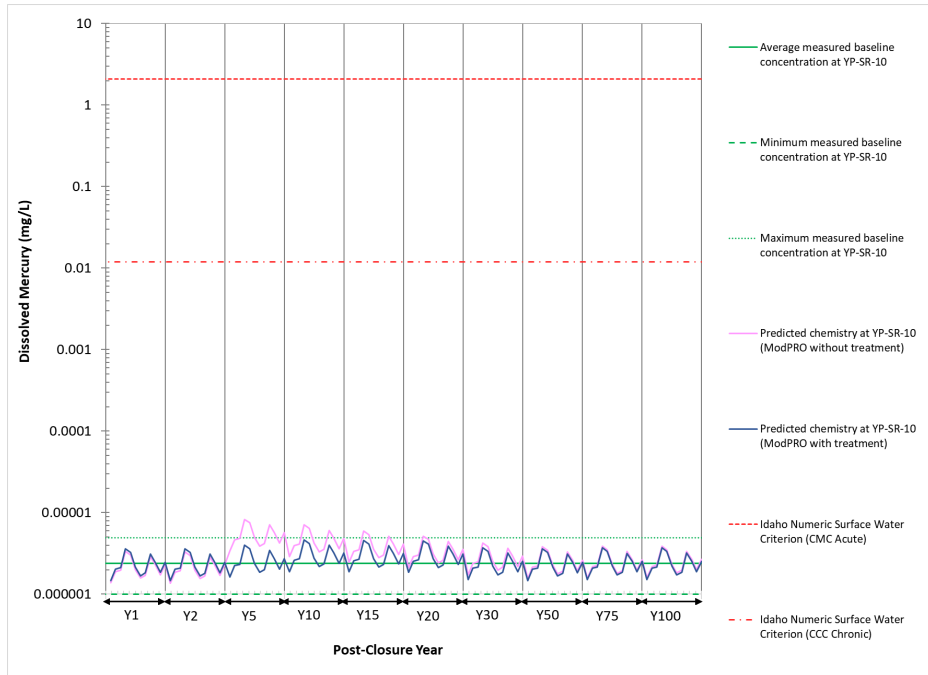

Figure B-15: Predicted Mercury Concentrations during Post-closure at Node YP-SR-10 – Treatment Evaluation Scenario

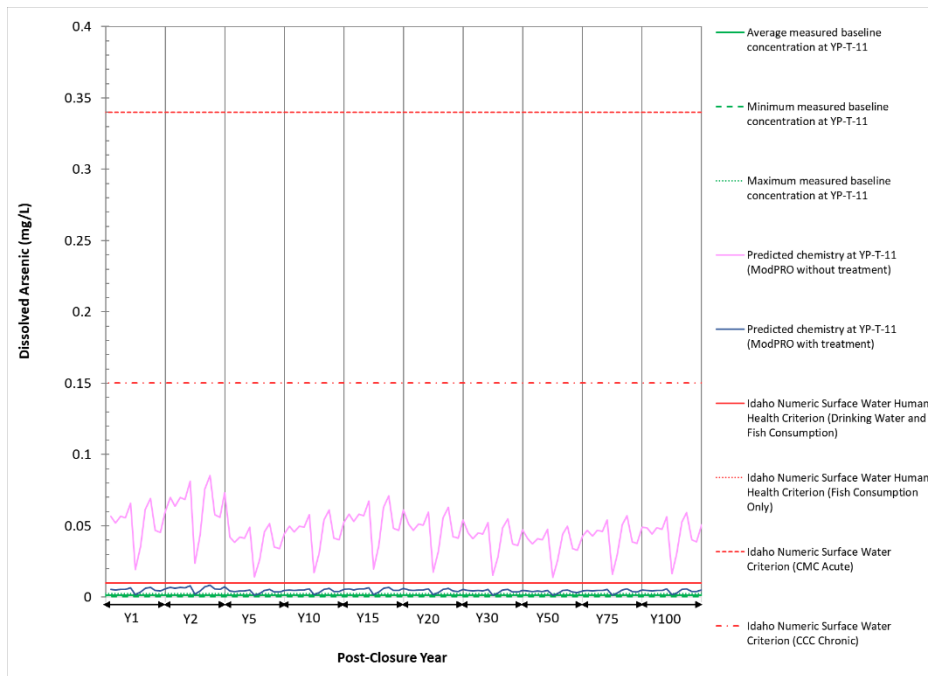

Figure B-16: Predicted Arsenic Concentrations during Post-closure at Node YP-T-11 – Treatment Evaluation Scenario

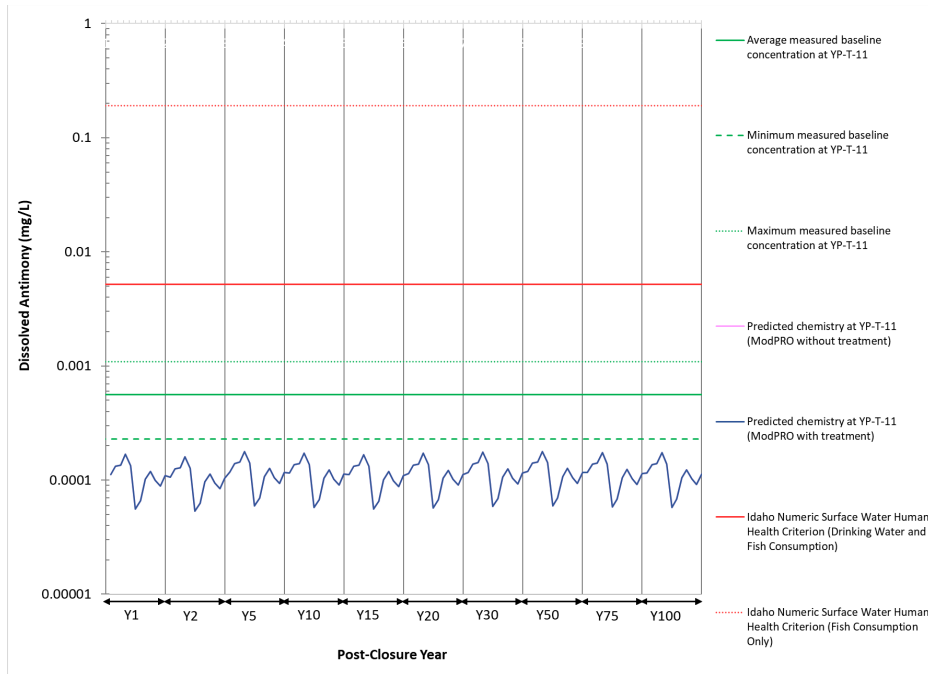

Figure B-17: Predicted Antimony Concentrations during Post-closure Node YP-T-11 – Treatment Evaluation Scenario

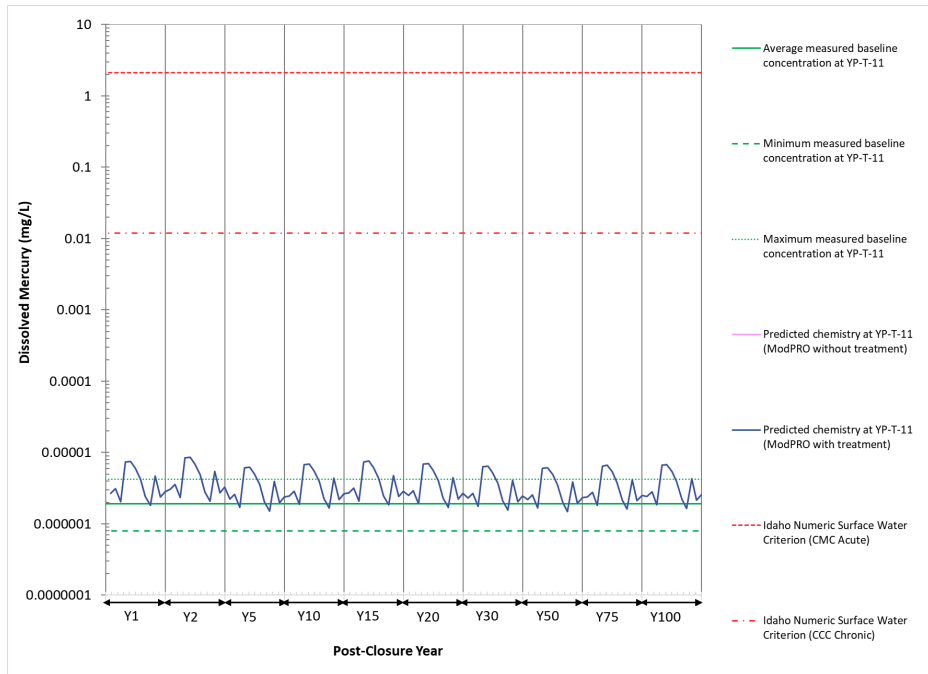

Figure B-18: Predicted Mercury Concentrations during Post-closure at Node YP-T-11 – Treatment Evaluation Scenario

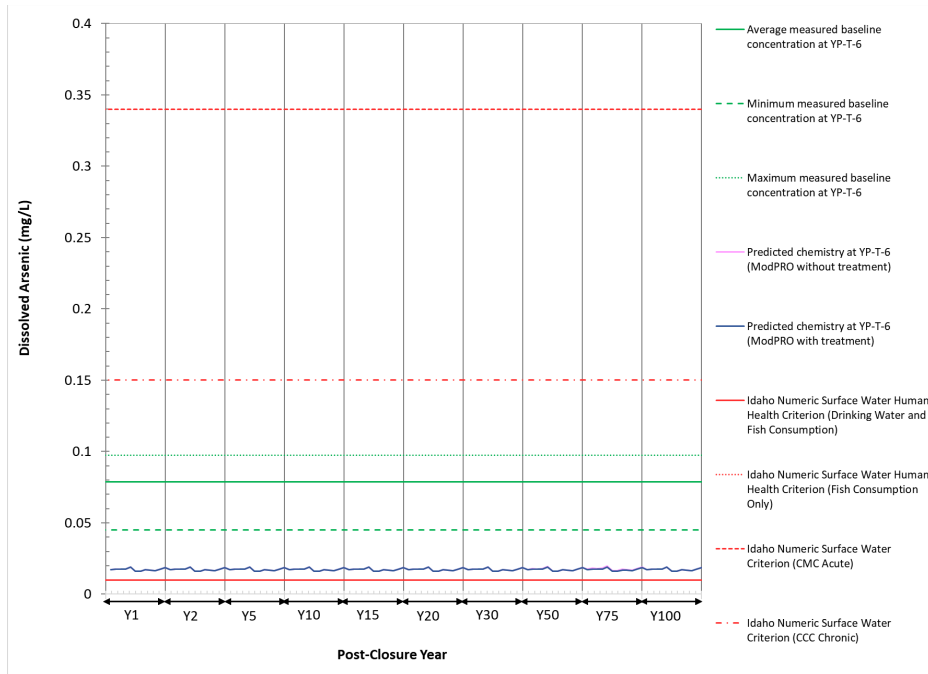

Figure B-19: Predicted Arsenic Concentrations during Post-closure at Node YP-T-6 – Treatment Evaluation Scenario

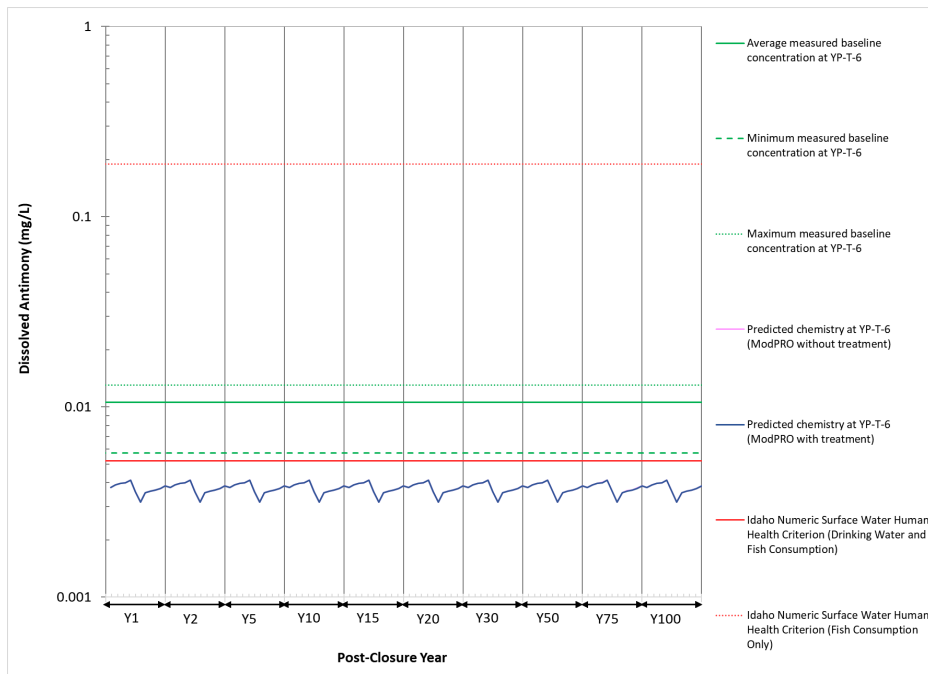

Figure B-20: Predicted Antimony Concentrations during Post-closure Node YP-T-6 – Treatment Evaluation Scenario

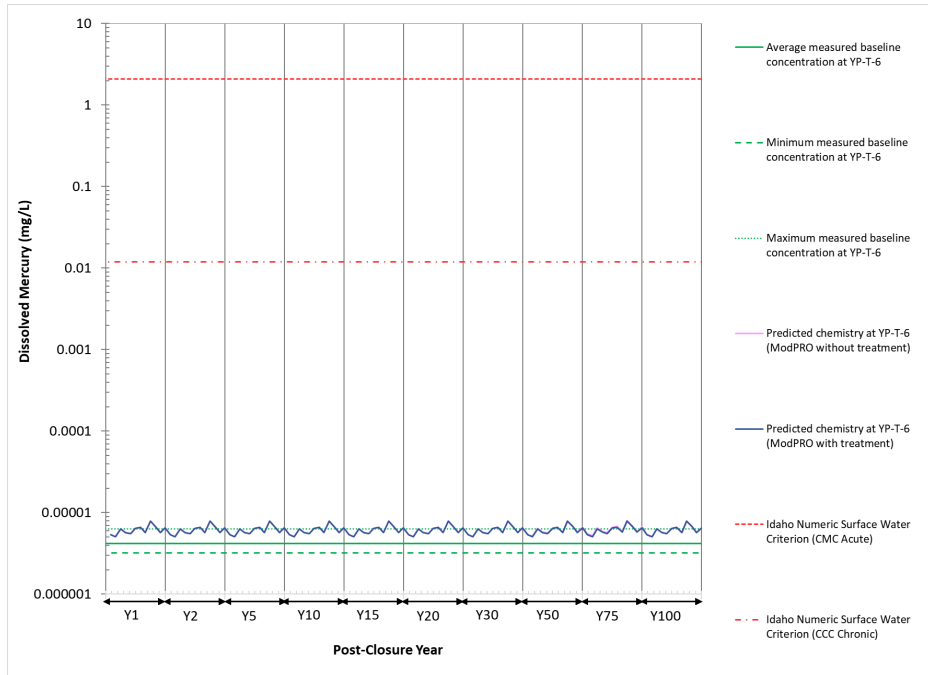

Figure B-21: Predicted Mercury Concentrations during Post-closure at Node YP-T-6 – Treatment Evaluation Scenario

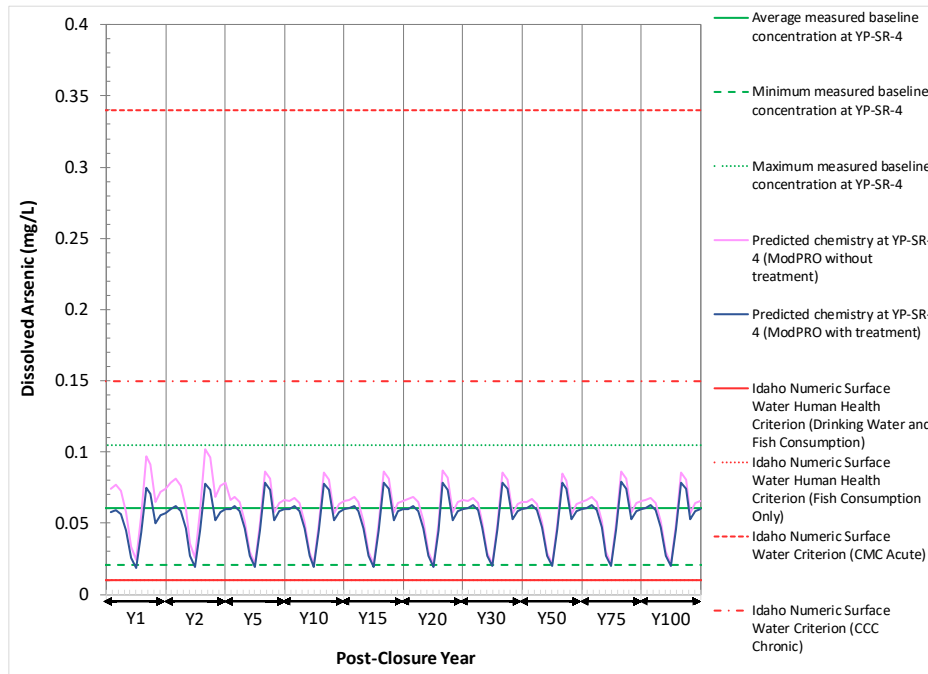

Figure B-22: Predicted Arsenic Concentrations during Post Closure at Node YP-SR-4 – Treatment Evaluation Scenario

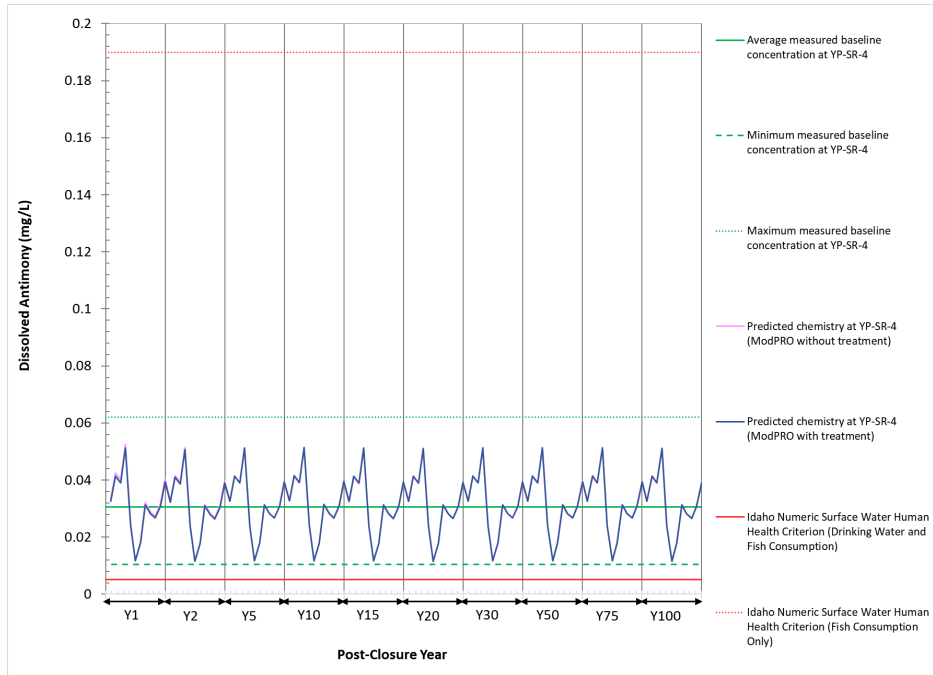

Figure B-23: Predicted Antimony Concentrations during Post Closure at Node YP-SR-4 – Treatment Evaluation Scenario

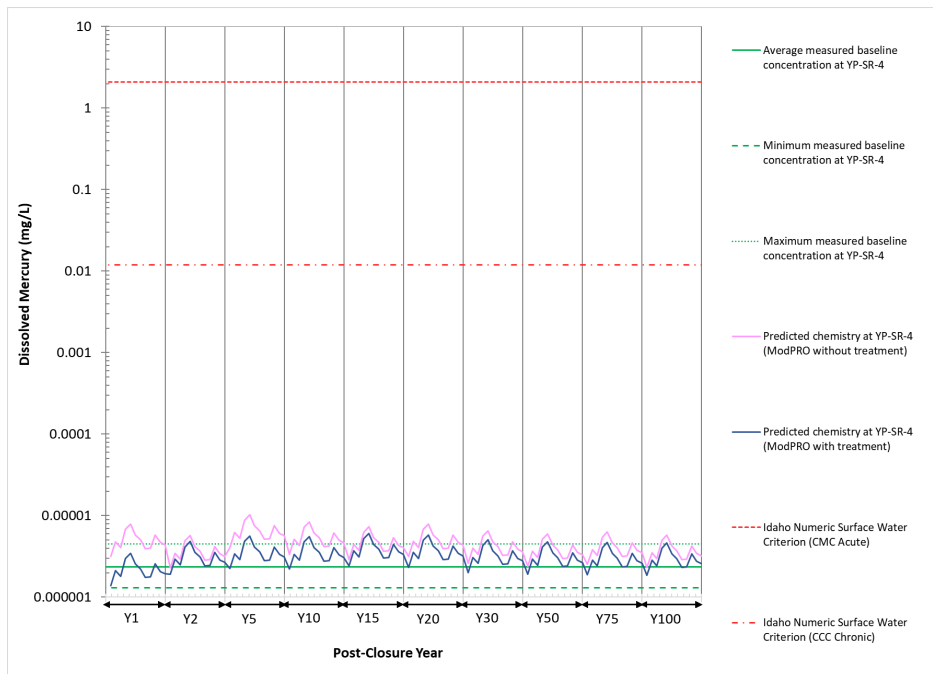

Figure B-24: Predicted Mercury Concentrations during Post Closure at Node YP-SR-4 – Treatment Evaluation Scenario

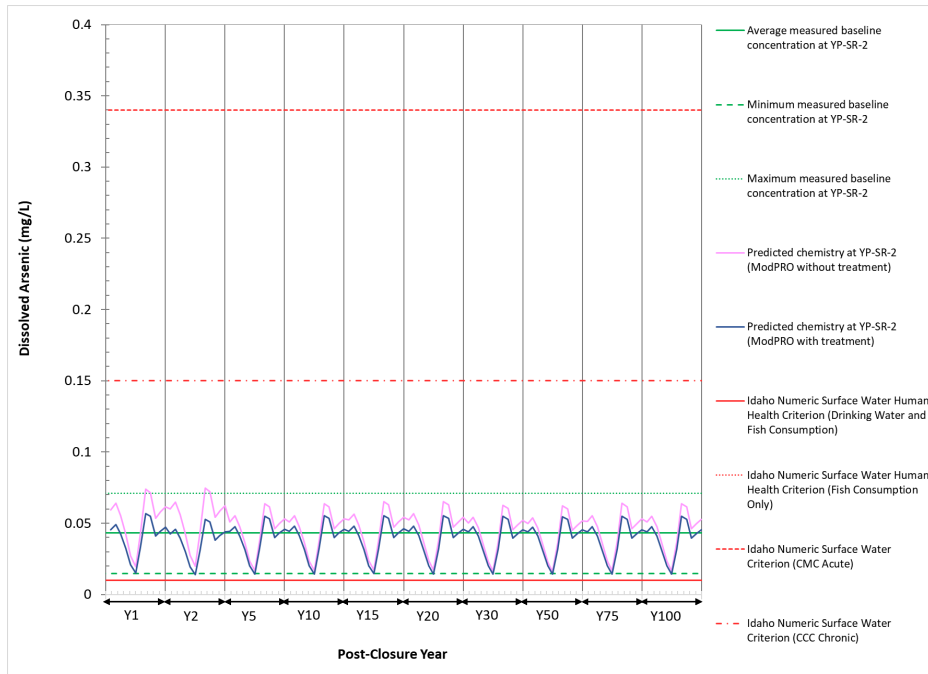

Figure B-25: Predicted Arsenic Concentrations during Post Closure at Node YP-SR-2 – Treatment Evaluation Scenario

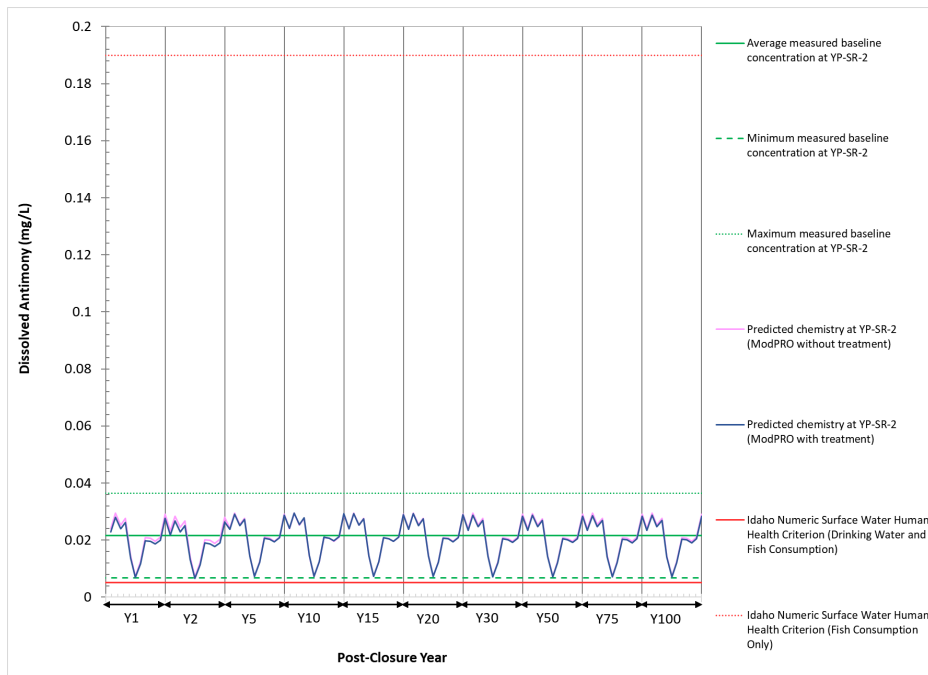

Figure B-26: Predicted Antimony Concentrations during Post Closure at Node YP-SR-2 – Treatment Evaluation Scenario

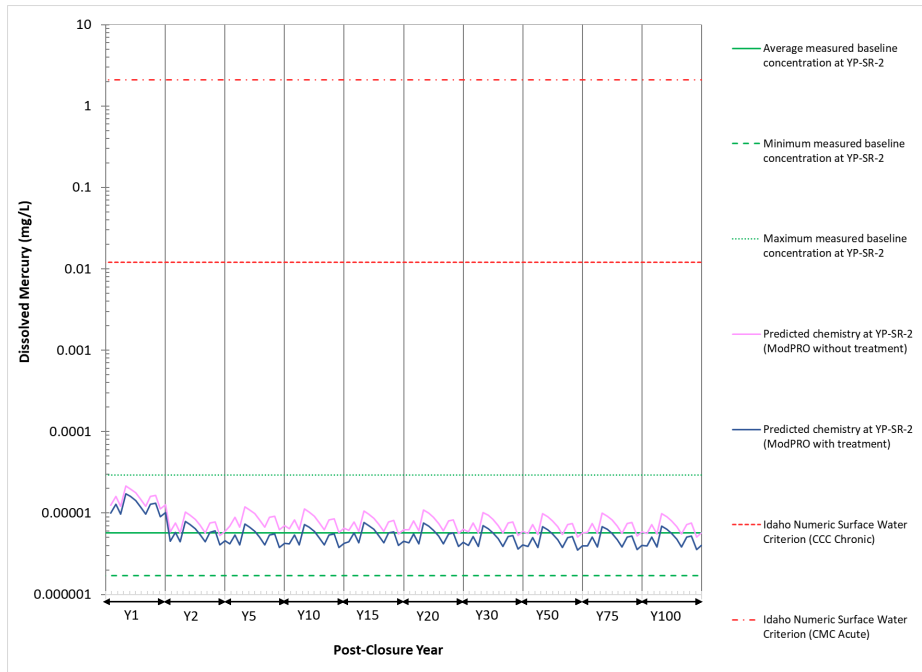

Figure B-27: Predicted Mercury Concentrations during Post Closure at Node YP-SR-2 – Treatment Evaluation Scenario

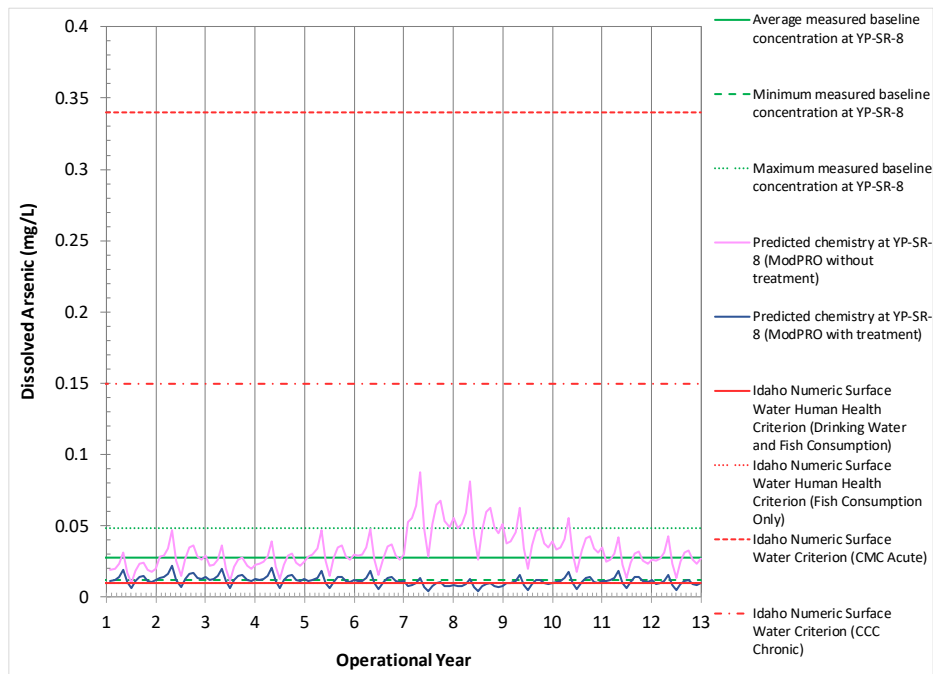

Figure B-28: Predicted Arsenic Concentrations during Operations at Node YP-SR-8 – Treatment Evaluation Scenario

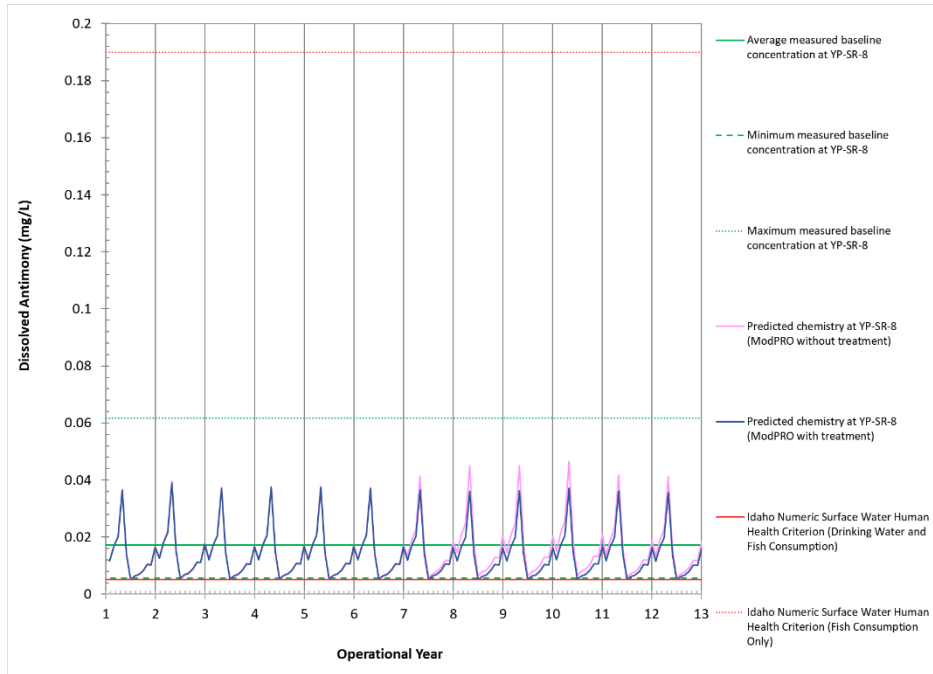

Figure B-29: Predicted Antimony Concentrations during Operations at Node YP-SR-8 – Treatment Evaluation Scenario

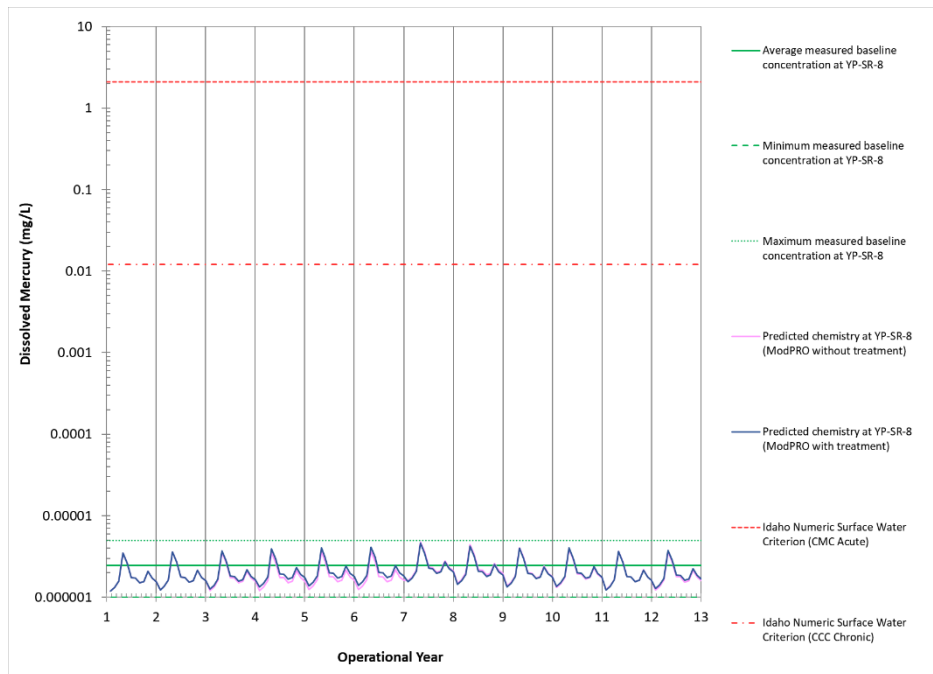

Figure B-30: Predicted Mercury Concentrations during Operations at Node YP-SR-8 – Treatment Evaluation Scenario

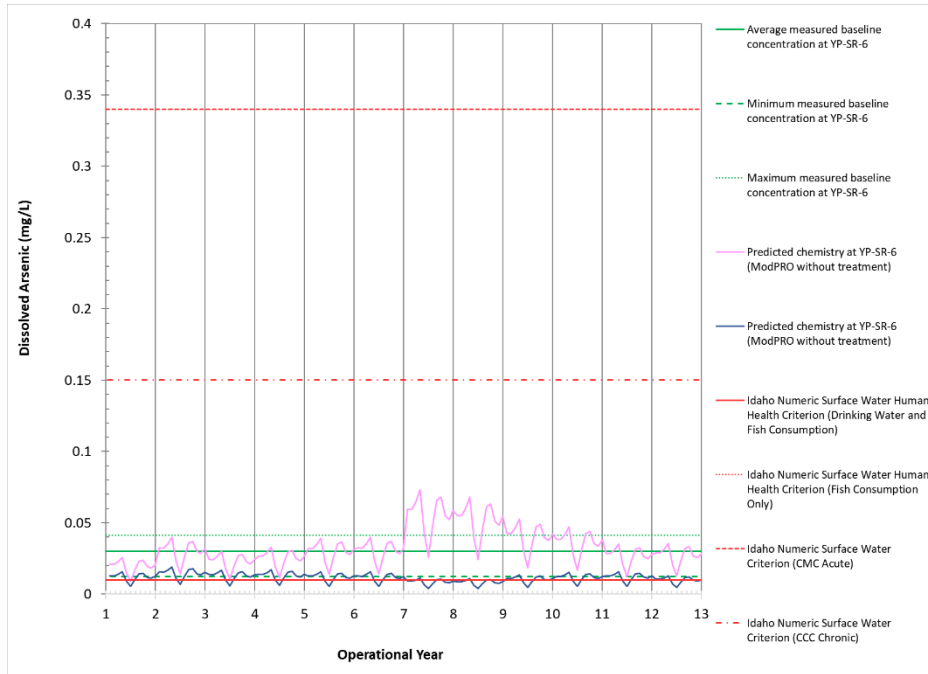

Figure B-31: Predicted Arsenic Concentrations during Operations at Node YP-SR-6 – Treatment Evaluation Scenario

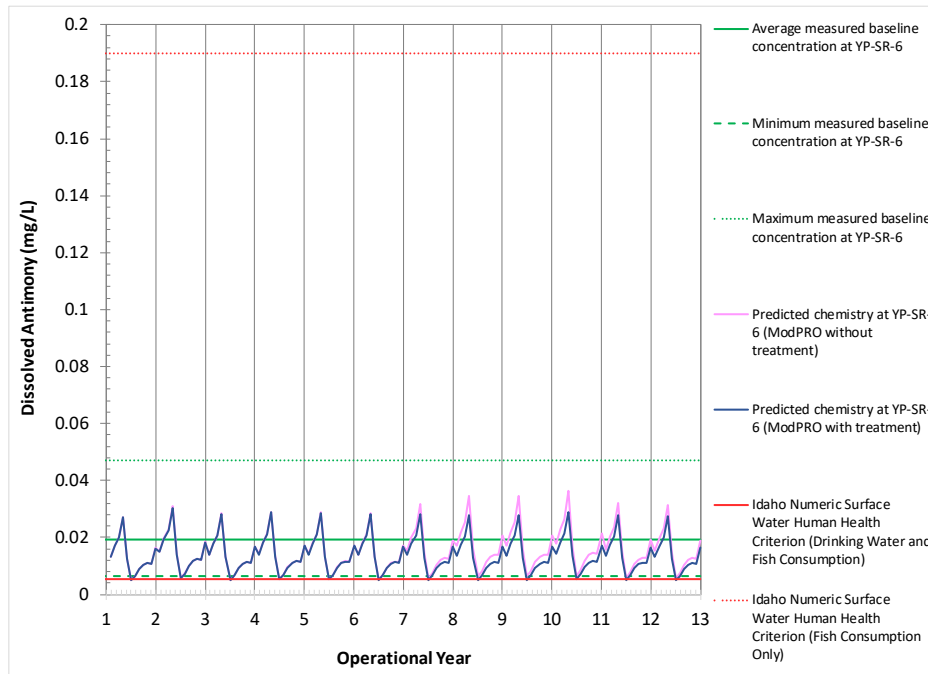

Figure B-32: Predicted Antimony Concentrations during Operations at Node YP-SR-6 – Treatment Evaluation Scenario

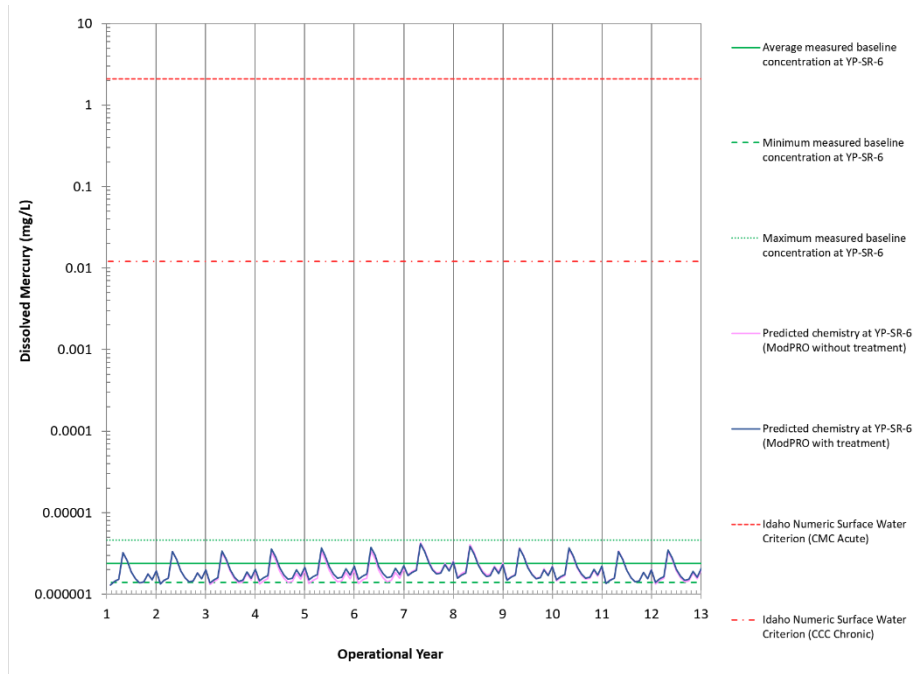

Figure B-33: Predicted Mercury Concentrations during Operations at Node YP-SR-6 – Treatment Evaluation Scenario

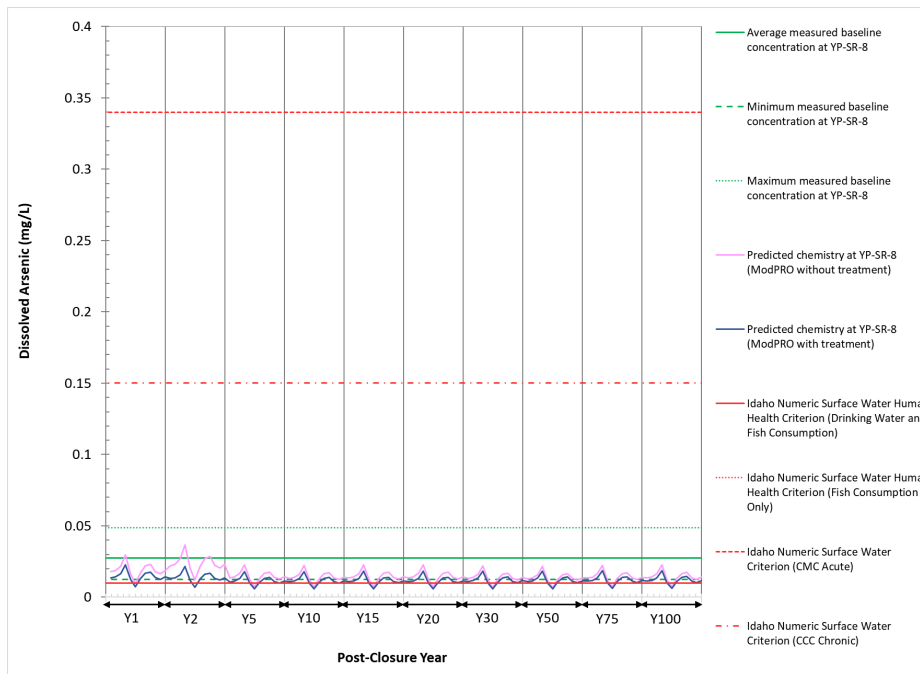

Figure B-34: Predicted Arsenic Concentrations during Post-closure at Node YP-SR-8 – Treatment Evaluation Scenario

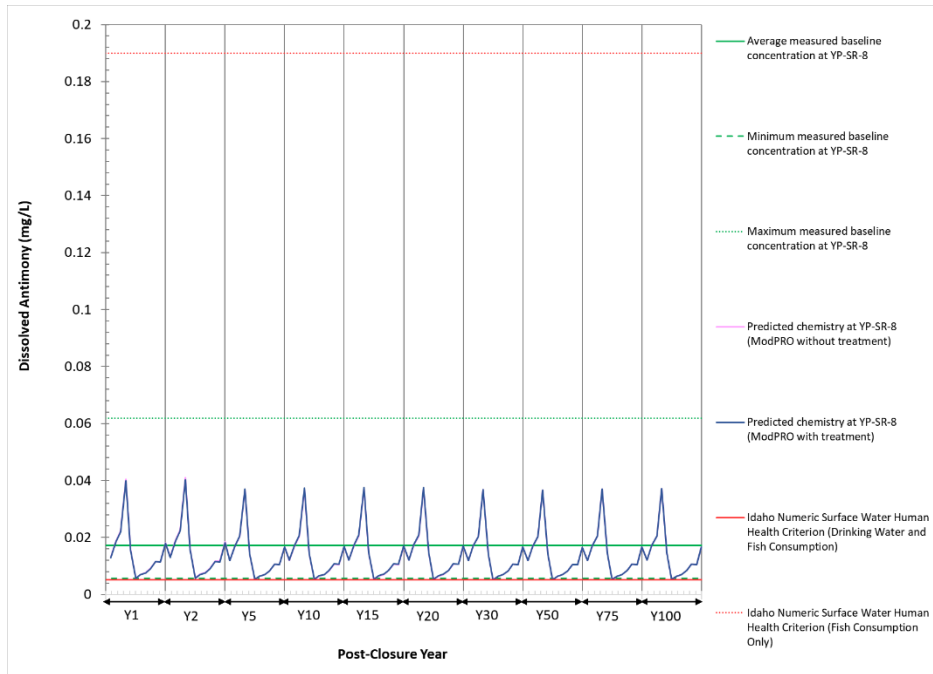

Figure B-35: Predicted Antimony Concentrations during Post-closure Node YP-SR-8 – Treatment Evaluation Scenario

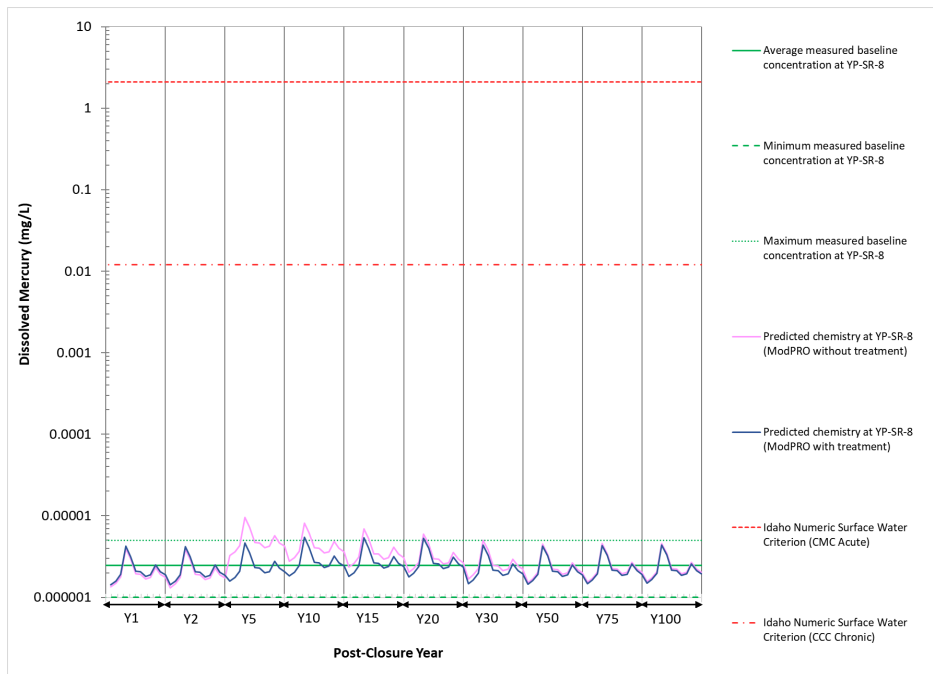

Figure B-36: Predicted Mercury Concentrations during Post-closure at Node YP-SR-8 – Treatment Evaluation Scenario

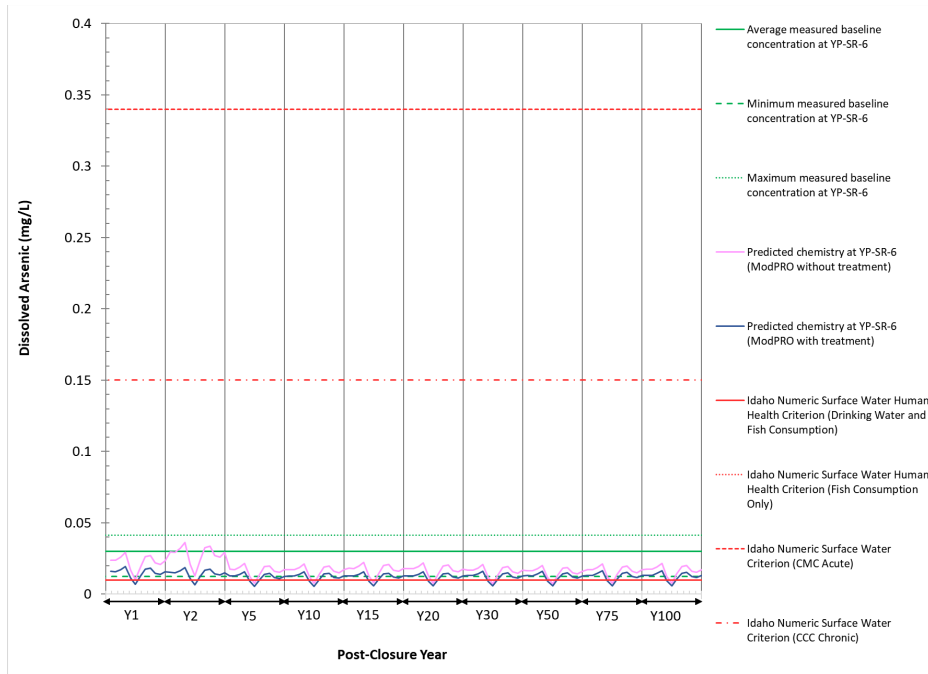

Figure B-37: Predicted Arsenic Concentrations during Post-closure at Node YP-SR-6 – Treatment Evaluation Scenario

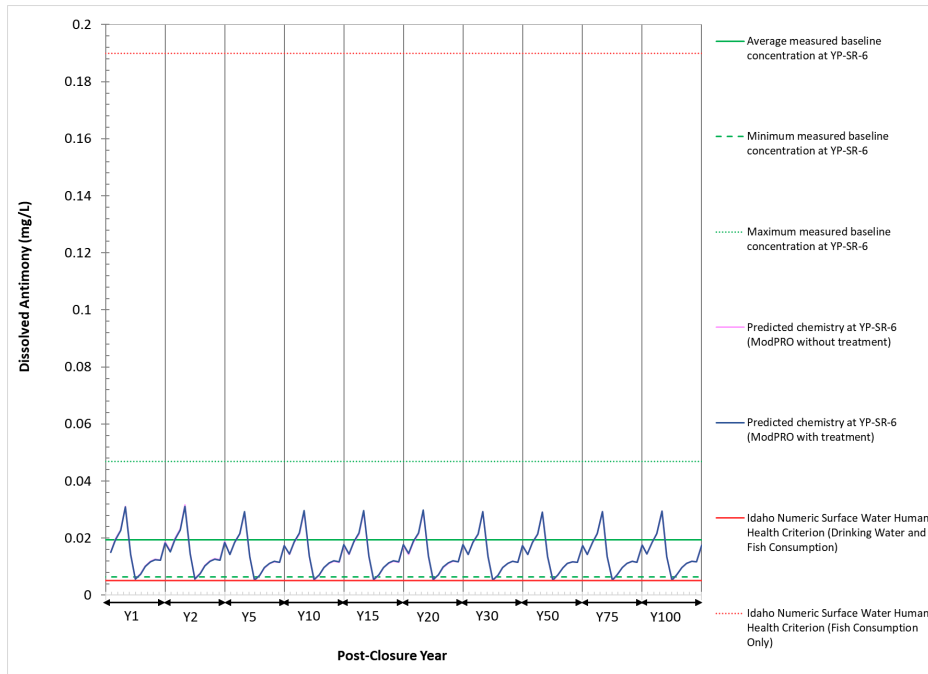

Figure B-38: Predicted Antimony Concentrations during Post-closure Node YP-SR-6 – Treatment Evaluation Scenario

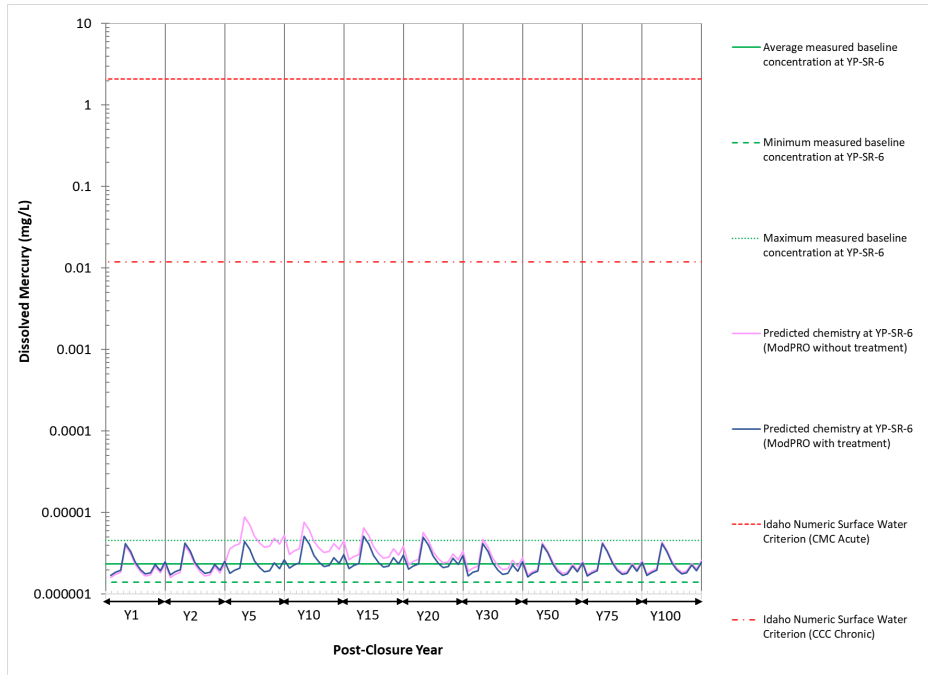

Figure B-39: Predicted Mercury Concentrations during Post-closure at Node YP-SR-6 – Treatment Evaluation Scenario

## Appendix B: Temperature Tables

---



Table B-1. Comparison of Simulated Temperatures for EOY6 ModPRO Configuration for the Maximum Weekly Summer Condition for the ModPRO and ModPRO with Plan Mine Years 3, 8, and 12

Reach Number	ModPRO Average Temperature °C	ModPRO Minimum Temperature °C	ModPRO Maximum Temperature °C	ModPRO, Plan Mine Year 3 Average Temperature °C	ModPRO, Plan Mine Year 3 Minimum Temperature °C	ModPRO, Plan Mine Year 3 Maximum Temperature °C	ModPRO, Plan Mine Year 8 Average Temperature °C	ModPRO, Plan Mine Year 8 Minimum Temperature °C	ModPRO, Plan Mine Year 8 Maximum Temperature °C	ModPRO, Plan Mine Year 12 Average Temperature °C	ModPRO, Plan Mine Year 12 Minimum Temperature °C	ModPRO, Plan Mine Year 12 Maximum Temperature °C
1	9.81	7.06	13.54	9.81	7.06	13.54	9.81	7.06	13.54	9.81	7.06	13.54
2	10.02	7.34	13.79	10.02	7.34	13.79	10.02	7.34	13.79	10.02	7.34	13.79
3	8.75	6.36	11.86	8.75	6.36	11.86	8.75	6.36	11.86	8.75	6.36	11.86
4	9.90	7.28	13.41	9.90	7.28	13.41	9.90	7.28	13.41	9.90	7.28	13.41
5	10.12	7.49	13.55	10.12	7.49	13.55	10.12	7.49	13.55	10.12	7.49	13.55
6	10.30	7.81	13.40	10.30	7.81	13.40	10.30	7.81	13.40	10.30	7.81	13.40
7	10.64	7.96	13.83	10.63	7.97	13.81	10.37	8.02	13.19	10.50	8.20	13.26
8	11.37	8.97	14.60	11.37	8.97	14.60	11.37	8.97	14.60	11.37	8.97	14.60
9	11.39	9.10	14.44	11.39	9.10	14.44	11.39	9.10	14.44	11.39	9.10	14.44
10	9.98	8.08	12.73	9.98	8.08	12.73	9.98	8.08	12.73	9.98	8.08	12.73
11	10.85	8.74	13.67	10.85	8.74	13.67	10.85	8.74	13.67	10.85	8.74	13.67
12	9.01	7.03	11.62	9.01	7.03	11.62	9.01	7.03	11.62	9.01	7.03	11.62
13	10.04	8.06	12.68	10.04	8.06	12.68	10.04	8.06	12.68	10.04	8.06	12.68
14	9.94	7.99	12.60	9.94	7.99	12.60	9.94	7.99	12.60	9.94	7.99	12.60
15	16.32	5.41	29.25	16.32	5.41	29.25	16.32	5.41	29.25	16.32	5.41	29.25
16	17.44	5.93	30.57	17.44	5.93	30.57	17.44	5.93	30.57	17.44	5.93	30.57
17	18.08	6.04	31.13	18.08	6.04	31.13	18.08	6.04	31.13	18.08	6.04	31.13
18	10.65	7.81	14.30	10.65	7.81	14.30	10.65	7.81	14.30	10.65	7.81	14.30
19	10.22	8.09	13.20	10.22	8.09	13.20	10.22	8.09	13.20	10.22	8.09	13.20
20	10.98	9.02	13.78	10.98	9.02	13.78	10.98	9.02	13.78	10.98	9.02	13.78
21	11.52	8.85	15.45	11.52	8.85	15.45	11.52	8.85	15.45	11.52	8.85	15.45
22	11.82	7.86	17.26	11.82	7.86	17.26	11.82	7.86	17.26	11.82	7.86	17.26
23	12.51	7.62	19.31	12.51	7.62	19.31	12.51	7.62	19.31	12.51	7.62	19.31
24	12.94	7.80	20.07	12.80	7.72	19.85	11.87	7.85	17.49	12.06	8.18	17.48
25	11.89	7.90	17.06	11.80	8.20	16.51	10.86	8.04	14.61	11.09	8.55	14.48
26	11.53	9.03	15.10	11.53	9.03	15.10	11.53	9.03	15.10	11.53	9.03	15.10
27	11.89	9.08	15.85	11.89	9.08	15.85	11.89	9.08	15.85	11.89	9.08	15.85
28	12.51	7.73	18.89	12.39	7.99	18.32	11.40	7.85	16.37	11.57	8.34	16.13
29	8.45	6.12	11.40	8.45	6.12	11.40	8.45	6.12	11.40	8.45	6.12	11.40
30	8.66	6.84	11.10	8.66	6.84	11.10	8.66	6.84	11.10	8.66	6.84	11.10
31	8.65	6.88	11.02	8.65	6.88	11.02	8.65	6.88	11.02	8.65	6.88	11.02
32	9.88	8.68	11.48	9.88	8.68	11.48	9.88	8.68	11.48	9.88	8.68	11.48
33	10.04	8.57	11.83	10.04	8.57	11.83	10.04	8.57	11.83	10.04	8.57	11.83
34	12.66	7.72	19.26	12.55	7.93	18.83	11.65	7.78	17.14	11.78	8.22	16.89
35	10.92	9.03	13.20	10.92	9.03	13.20	10.92	9.03	13.20	10.92	9.03	13.20
36	11.18	8.54	14.42	11.18	8.54	14.42	11.18	8.54	14.42	11.18	8.54	14.42



Reach Number	ModPRO Average Temperature °C	ModPRO Minimum Temperature °C	ModPRO Maximum Temperature °C	ModPRO, Plan Mine Year 3 Average Temperature °C	ModPRO, Plan Mine Year 3 Minimum Temperature °C	ModPRO, Plan Mine Year 3 Maximum Temperature °C	ModPRO, Plan Mine Year 8 Average Temperature °C	ModPRO, Plan Mine Year 8 Minimum Temperature °C	ModPRO, Plan Mine Year 8 Maximum Temperature °C	ModPRO, Plan Mine Year 12 Average Temperature °C	ModPRO, Plan Mine Year 12 Minimum Temperature °C	ModPRO, Plan Mine Year 12 Maximum Temperature °C
37	11.11	8.47	14.32	11.11	8.47	14.32	11.11	8.47	14.32	11.11	8.47	14.32
38	11.39	8.03	16.19	11.39	8.03	16.19	11.39	8.03	16.19	11.39	8.03	16.19
39	12.71	7.72	19.30	12.60	7.92	18.90	11.72	7.76	17.30	11.84	8.18	17.05
40	12.65	7.70	19.14	12.54	7.89	18.76	11.68	7.74	17.20	11.80	8.16	16.97
41	12.54	7.67	18.90	12.45	7.86	18.55	11.61	7.71	17.06	11.74	8.13	16.85
42	12.59	7.69	18.97	12.49	7.86	18.64	11.67	7.70	17.19	11.79	8.11	16.98
43	9.98	7.01	14.17	9.98	7.01	14.17	9.98	7.01	14.17	9.98	7.01	14.17
44	10.28	7.22	14.86	10.28	7.22	14.86	10.28	7.22	14.86	10.28	7.22	14.86
45	9.02	6.75	12.04	9.02	6.75	12.04	9.02	6.75	12.04	9.02	6.75	12.04
46	10.37	7.24	15.00	10.37	7.24	15.00	10.37	7.24	15.00	10.37	7.24	15.00
47	8.53	6.28	11.52	8.53	6.28	11.52	8.53	6.28	11.52	8.53	6.28	11.52
48	10.55	7.26	15.39	10.55	7.26	15.39	10.55	7.26	15.39	10.55	7.26	15.39
49	10.74	7.32	15.78	10.74	7.32	15.78	10.74	7.32	15.78	10.74	7.32	15.78
50	11.26	9.93	12.84	11.26	9.93	12.84	11.26	9.93	12.84	11.26	9.93	12.84
51	11.47	9.87	13.46	11.47	9.87	13.46	11.47	9.87	13.46	11.47	9.87	13.46
52	11.27	9.59	13.21	11.27	9.59	13.21	11.27	9.59	13.21	11.27	9.59	13.21
53	11.30	10.03	12.78	11.30	10.03	12.78	11.30	10.03	12.78	11.30	10.03	12.78
54	11.14	7.62	16.14	11.14	7.62	16.14	11.14	7.62	16.14	11.14	7.62	16.14
55	11.98	7.67	17.65	11.96	7.76	17.54	11.54	7.67	16.84	11.63	7.92	16.73

Notes:  
 Column shading is used to separate the scenarios.  
 Abbreviations:  
 °C = degree Celsius  
 EOY = end of year  
 ModPRO = Modified Plan of Restoration and Operations

Table B-2. Comparison of Simulated Temperatures for EOY18 ModPRO Configuration for the Maximum Weekly Summer Condition for the ModPRO and ModPRO with WTP Effluent Discharge Temperature of Either 21.6 °C or 11.5 °C

Reach Number	ModPRO Average Temperature °C	ModPRO Minimum Temperature °C	ModPRO Maximum Temperature °C	ModPRO, Plan Effluent Discharge Temperature of 21.6 °C Average Temperature °C	ModPRO, Plan Effluent Discharge Temperature of 21.6 °C Minimum Temperature °C	ModPRO, Plan Effluent Discharge Temperature of 21.6 °C Maximum Temperature °C	ModPRO, Plan Effluent Discharge Temperature of 11.5 °C Average Temperature °C	ModPRO, Plan Effluent Discharge Temperature of 11.5 °C Minimum Temperature °C	ModPRO, Plan Effluent Discharge Temperature of 11.5 °C Maximum Temperature °C
1	9.81	7.05	13.54	9.81	7.05	13.54	9.81	7.05	13.54
2	10.02	7.33	13.80	10.02	7.33	13.80	10.02	7.33	13.80
3	8.75	6.36	11.91	8.75	6.36	11.91	8.75	6.36	11.91
4	9.85	7.21	13.40	9.85	7.21	13.40	9.85	7.21	13.40
5	10.05	7.39	13.52	10.05	7.39	13.52	10.05	7.39	13.52
6	10.21	7.66	13.39	10.21	7.66	13.39	10.21	7.66	13.39
7	10.54	7.75	13.86	10.54	7.75	13.86	10.54	7.75	13.86
8	11.68	8.90	15.49	11.68	8.90	15.49	11.68	8.90	15.49
9	13.69	8.80	20.65	13.69	8.80	20.65	13.69	8.80	20.65
10	9.91	7.85	12.87	9.91	7.85	12.87	9.91	7.85	12.87



Reach Number	ModPRO Average Temperature °C	ModPRO Minimum Temperature °C	ModPRO Maximum Temperature °C	ModPRO, Plan Effluent Discharge Temperature of 21.6 °C Average Temperature °C	ModPRO, Plan Effluent Discharge Temperature of 21.6 °C Minimum Temperature °C	ModPRO, Plan Effluent Discharge Temperature of 21.6 °C Maximum Temperature °C	ModPRO, Plan Effluent Discharge Temperature of 11.5 °C Average Temperature °C	ModPRO, Plan Effluent Discharge Temperature of 11.5 °C Minimum Temperature °C	ModPRO, Plan Effluent Discharge Temperature of 11.5 °C Maximum Temperature °C
11	11.91	8.69	16.88	11.91	8.69	16.88	11.91	8.69	16.88
12	13.84	9.16	20.43	13.84	9.16	20.43	13.84	9.16	20.43
13	8.88	6.74	11.71	8.88	6.74	11.71	8.88	6.74	11.71
14	11.33	7.49	16.59	11.33	7.49	16.59	11.33	7.49	16.59
15	13.79	9.22	20.10	13.79	9.22	20.10	13.79	9.22	20.10
16	14.24	9.67	20.44	14.24	9.67	20.44	14.24	9.67	20.44
17	14.45	9.95	20.50	14.45	9.95	20.50	14.45	9.95	20.50
18	14.73	10.11	20.90	14.73	10.11	20.90	14.73	10.11	20.90
19	14.96	10.05	21.48	14.96	10.05	21.48	14.96	10.05	21.48
20	10.15	8.02	13.09	10.15	8.02	13.09	10.15	8.02	13.09
21	11.09	8.94	14.20	11.09	8.94	14.20	11.09	8.94	14.20
22	11.56	8.90	15.74	11.56	8.90	15.74	11.56	8.90	15.74
23	14.97	10.15	21.46	14.71	9.67	21.49	14.71	9.67	21.49
24	15.53	10.72	21.95	14.92	9.58	22.01	14.92	9.58	22.01
25	13.78	9.47	19.30	13.85	9.58	19.30	13.21	8.93	18.68
26	11.61	9.33	14.91	11.61	9.33	14.91	11.61	9.33	14.91
27	12.46	8.85	17.67	12.46	8.85	17.67	12.46	8.85	17.67
28	14.02	9.28	20.07	14.08	9.38	20.07	13.51	8.79	19.52
29	8.56	6.30	11.42	8.56	6.30	11.42	8.56	6.30	11.42
30	8.82	7.01	11.26	8.82	7.01	11.26	8.82	7.01	11.26
31	10.90	7.39	16.19	10.90	7.39	16.19	10.90	7.39	16.19
32	12.36	7.54	19.96	12.36	7.54	19.96	12.36	7.54	19.96
33	12.59	7.57	20.49	12.59	7.57	20.49	12.59	7.57	20.49
34	14.08	9.08	20.48	14.14	9.17	20.48	13.63	8.65	20.01
35	14.17	9.07	20.75	14.22	9.16	20.75	13.73	8.65	20.30
36	11.60	9.53	14.33	11.60	9.53	14.33	11.60	9.53	14.33
37	12.47	9.13	17.37	12.47	9.13	17.37	12.47	9.13	17.37
38	14.21	9.06	20.93	14.27	9.15	20.93	13.81	8.67	20.52
39	10.29	8.23	13.56	10.29	8.23	13.56	10.29	8.23	13.56
40	11.40	8.59	15.92	11.40	8.59	15.92	11.40	8.59	15.92
41	14.31	9.02	21.18	14.36	9.10	21.18	13.93	8.65	20.80
42	14.40	9.04	21.33	14.45	9.12	21.33	14.04	8.68	20.97
43	9.98	7.02	14.17	9.98	7.02	14.17	9.98	7.02	14.17
44	10.30	7.25	14.84	10.30	7.25	14.84	10.30	7.25	14.84
45	9.47	7.43	12.26	9.47	7.43	12.26	9.47	7.43	12.26
46	10.40	7.31	14.97	10.40	7.31	14.97	10.40	7.31	14.97
47	8.79	6.72	11.55	8.79	6.72	11.55	8.79	6.72	11.55
48	10.53	7.33	15.24	10.53	7.33	15.24	10.53	7.33	15.24
49	10.78	7.41	15.75	10.78	7.41	15.75	10.78	7.41	15.75



Reach Number	ModPRO Average Temperature °C	ModPRO Minimum Temperature °C	ModPRO Maximum Temperature °C	ModPRO, Plan Effluent Discharge Temperature of 21.6 °C Average Temperature °C	ModPRO, Plan Effluent Discharge Temperature of 21.6 °C Minimum Temperature °C	ModPRO, Plan Effluent Discharge Temperature of 21.6 °C Maximum Temperature °C	ModPRO, Plan Effluent Discharge Temperature of 11.5 °C Average Temperature °C	ModPRO, Plan Effluent Discharge Temperature of 11.5 °C Minimum Temperature °C	ModPRO, Plan Effluent Discharge Temperature of 11.5 °C Maximum Temperature °C
50	17.37	11.55	26.08	17.37	11.55	26.08	17.37	11.55	26.08
51	14.95	9.84	20.93	14.95	9.84	20.93	14.95	9.84	20.93
52	11.10	7.60	16.17	11.10	7.60	16.17	11.10	7.60	16.17
53	13.32	8.58	19.52	13.36	8.63	19.52	13.10	8.35	19.29

Notes:  
 Column shading is used to separate the scenarios.  
 Abbreviations:  
 °C = degree Celsius  
 EOY = end of year  
 ModPRO = Modified Plan of Restoration and Operations  
 WTP = water treatment plant

Table B-3. Comparison of Simulated Temperatures for EOY112 ModPRO Configuration for the Maximum Weekly Summer Condition for the ModPRO and ModPRO with WTP Effluent Discharge Temperature of Either 21.6 °C or 11.5 °C

Reach Number	ModPRO Average Temperature °C	ModPRO Minimum Temperature °C	ModPRO Maximum Temperature °C	ModPRO, Plan Effluent Discharge Temperature of 21.6 °C Average Temperature °C	ModPRO, Plan Effluent Discharge Temperature of 21.6 °C Minimum Temperature °C	ModPRO, Plan Effluent Discharge Temperature of 21.6 °C Maximum Temperature °C	ModPRO, Plan Effluent Discharge Temperature of 11.5 °C Average Temperature °C	ModPRO, Plan Effluent Discharge Temperature of 11.5 °C Minimum Temperature °C	ModPRO, Plan Effluent Discharge Temperature of 11.5 °C Maximum Temperature °C
1	9.81	7.05	13.54	9.81	7.05	13.54	9.81	7.05	13.54
2	10.02	7.33	13.80	10.02	7.33	13.80	10.02	7.33	13.80
3	8.75	6.36	11.91	8.75	6.36	11.91	8.75	6.36	11.91
4	9.85	7.21	13.40	9.85	7.21	13.40	9.85	7.21	13.40
5	10.05	7.39	13.52	10.05	7.39	13.52	10.05	7.39	13.52
6	10.21	7.66	13.39	10.21	7.66	13.39	10.21	7.66	13.39
7	10.54	7.75	13.86	10.54	7.75	13.86	10.54	7.75	13.86
8	11.68	8.90	15.47	11.68	8.90	15.47	11.68	8.90	15.47
9	12.95	8.80	19.22	12.95	8.80	19.22	12.95	8.80	19.22
10	9.91	7.85	12.87	9.91	7.85	12.87	9.91	7.85	12.87
11	11.21	8.69	15.18	11.21	8.69	15.18	11.21	8.69	15.18
12	12.86	9.22	18.53	12.86	9.22	18.53	12.86	9.22	18.53
13	8.90	6.77	11.72	8.90	6.77	11.72	8.90	6.77	11.72
14	10.70	7.52	15.02	10.70	7.52	15.02	10.70	7.52	15.02
15	12.87	9.32	18.30	12.87	9.32	18.30	12.87	9.32	18.30
16	13.34	9.79	18.76	13.34	9.79	18.76	13.34	9.79	18.76
17	13.59	10.08	18.94	13.59	10.08	18.94	13.59	10.08	18.94
18	13.89	10.24	19.35	13.89	10.24	19.35	13.89	10.24	19.35
19	14.10	10.17	19.93	14.10	10.17	19.93	14.10	10.17	19.93
20	10.15	8.02	13.09	10.15	8.02	13.09	10.15	8.02	13.09
21	11.11	9.11	13.99	11.11	9.11	13.99	11.11	9.11	13.99
22	11.44	8.97	15.34	11.44	8.97	15.34	11.44	8.97	15.34
23	14.26	10.24	20.25	13.98	9.79	20.23	13.98	9.79	20.23
24	14.87	10.74	20.97	14.22	9.66	20.93	14.22	9.66	20.93



Reach Number	ModPRO Average Temperature °C	ModPRO Minimum Temperature °C	ModPRO Maximum Temperature °C	ModPRO, Plan Effluent Discharge Temperature of 21.6 °C Average Temperature °C	ModPRO, Plan Effluent Discharge Temperature of 21.6 °C Minimum Temperature °C	ModPRO, Plan Effluent Discharge Temperature of 21.6 °C Maximum Temperature °C	ModPRO, Plan Effluent Discharge Temperature of 11.5 °C Average Temperature °C	ModPRO, Plan Effluent Discharge Temperature of 11.5 °C Minimum Temperature °C	ModPRO, Plan Effluent Discharge Temperature of 11.5 °C Maximum Temperature °C
25	13.44	9.50	18.85	13.51	9.60	18.87	12.89	8.98	18.26
26	11.50	9.33	14.64	11.50	9.33	14.64	11.50	9.33	14.64
27	11.74	8.84	15.44	11.74	8.84	15.44	11.74	8.84	15.44
28	13.69	9.29	19.67	13.76	9.39	19.67	13.19	8.81	19.14
29	8.56	6.30	11.42	8.56	6.30	11.42	8.56	6.30	11.42
30	8.82	7.01	11.26	8.82	7.01	11.26	8.82	7.01	11.26
31	10.45	7.87	14.13	10.45	7.87	14.13	10.45	7.87	14.13
32	11.49	8.26	16.79	11.49	8.26	16.79	11.49	8.26	16.79
33	11.68	8.32	17.39	11.68	8.32	17.39	11.68	8.32	17.39
34	13.69	9.11	19.89	13.75	9.20	19.89	13.26	8.69	19.44
35	13.77	9.08	20.11	13.82	9.17	20.11	13.35	8.67	19.68
36	11.65	9.78	14.16	11.65	9.78	14.16	11.65	9.78	14.16
37	11.94	9.42	15.27	11.94	9.42	15.27	11.94	9.42	15.27
38	13.78	9.07	20.15	13.84	9.15	20.16	13.39	8.69	19.76
39	10.29	8.23	13.56	10.29	8.23	13.56	10.29	8.23	13.56
40	10.83	8.59	14.18	10.83	8.59	14.18	10.83	8.59	14.18
41	13.88	9.00	20.40	13.93	9.08	20.41	13.52	8.65	20.04
42	13.98	9.00	20.59	14.02	9.07	20.60	13.63	8.66	20.25
43	9.98	7.02	14.17	9.98	7.02	14.17	9.98	7.02	14.17
44	10.30	7.26	14.84	10.30	7.26	14.84	10.30	7.26	14.84
45	9.47	7.43	12.26	9.47	7.43	12.26	9.47	7.43	12.26
46	10.40	7.31	14.97	10.40	7.31	14.97	10.40	7.31	14.97
47	8.79	6.71	11.55	8.79	6.71	11.55	8.79	6.71	11.55
48	10.53	7.33	15.24	10.53	7.33	15.24	10.53	7.33	15.24
49	10.78	7.43	15.74	10.78	7.43	15.74	10.78	7.43	15.74
50	14.95	11.35	21.81	14.95	11.35	21.81	14.95	11.35	21.81
51	13.26	9.52	17.87	13.26	9.52	17.87	13.26	9.52	17.87
52	11.10	7.63	16.14	11.10	7.63	16.14	11.10	7.63	16.14
53	13.08	8.56	19.10	13.11	8.61	19.11	12.86	8.34	18.88

Notes:

Column shading is used to separate the scenarios.

Abbreviations:

°C = degree Celsius

EOY = end of year

ModPRO = Modified Plan of Restoration and Operations

WTP = water treatment plant

